

Temperature measuring transducer - MCR-SL-PT100-LP-I - 2864558

Please be informed that the data shown in this PDF Document is generated from our Online Catalog. Please find the complete data in the user's documentation. Our General Terms of Use for Downloads are valid (<http://phoenixcontact.com/download>)



MCR temperature transducers: programmable loop-powered temperature transducers for Pt 100 resistance thermometers

Product Features

- ✓ Freely programmable via MCR/PI-CONF-WIN
- ✓ Two-wire transmitter for Pt 100 resistance thermometers



Key commercial data

Packing unit	1 pc
Weight per Piece (excluding packing)	106.4 GRM
Custom tariff number	85437090
Country of origin	Germany

Technical data

Dimensions

Width	12.5 mm
Height	99 mm
Depth	114.5 mm

Ambient conditions

Ambient temperature (operation)	-40 °C ... 85 °C
Degree of protection	IP20

Input data

Configurable/programmable	Yes, programmable
Sensor types (RTD) that can be used	Pt 100 ; minimum measurement range 10 K
Connection method	2, 3, 4-wire

Temperature measuring transducer - MCR-SL-PT100-LP-I - 2864558

Technical data

Output data

Output name	Current output
Current output signal	4 mA ... 20 mA
	20 mA ... 4 mA
Output current with wire break	≤ 3.6 mA or ≥ 21 mA (adjustable)
Output current with short-circuit	≤ 3.6 mA or ≥ 21 mA (adjustable)
Output current range with overrange/underrange	≤ 20.5 mA / ≥ 3.8 mA (linear increase/decrease)
Load/output load current output	Max ($V_{\text{supply}} - 12$ V) / 0.023 A (current output)

Power supply

Designation	Loop-powered
Supply voltage range	12 V DC ... 35 V DC
Max. current consumption	< 3.5 mA

Connection data

Connection method	Pluggable screw connection
Conductor cross section solid min.	0.2 mm ²
Conductor cross section solid max.	2.5 mm ²
Conductor cross section AWG/kcmil min.	24
Conductor cross section AWG/kcmil max.	24
Conductor cross section stranded min.	0.2 mm ²
Conductor cross section stranded max.	2.5 mm ²
Stripping length	8 mm
Screw thread	M3

General

Step response (10-90%)	< 2 s
Pickup delay	4 s
Test voltage input/output	2 kV (50 Hz, 1 min.)
Noise emission	EN 61 326-1 (IEC 1326) and NAMUR EN 21
Noise immunity	EN 61 326-1 (IEC 1326) and NAMUR EN 21
Color	green
Housing material	Polyamide PA non-reinforced
Mounting position	any
Configuration	Using MCR-PI-CONF-WIN configuration software package
Conformance	CE-compliant
UL, USA / Canada	Class I, Div. 2, Groups A, B, C, D

Temperature measuring transducer - MCR-SL-PT100-LP-I - 2864558

Classifications

eCl@ss

eCl@ss 4.0	27200206
eCl@ss 4.1	27200206
eCl@ss 5.0	27200206
eCl@ss 5.1	27200206
eCl@ss 6.0	27200206
eCl@ss 7.0	27200206
eCl@ss 8.0	27200206

ETIM

ETIM 2.0	EC001446
ETIM 3.0	EC001446
ETIM 4.0	EC001446
ETIM 5.0	EC001446

UNSPSC

UNSPSC 6.01	30211506
UNSPSC 7.0901	39121008
UNSPSC 11	39121008
UNSPSC 12.01	39121008
UNSPSC 13.2	39121008

Approvals

Approvals

Approvals

UL Recognized / cUL Recognized / GOST / cULus Recognized

Ex Approvals

UL Listed / cUL Listed / cUL Listed / cULus Listed / cULus Listed

Approvals submitted

Approval details

Temperature measuring transducer - MCR-SL-PT100-LP-I - 2864558

Approvals

UL Recognized 

cUL Recognized 

GOST 

cULus Recognized 

Accessories

Accessories

Configuration and diagnostics

Configuration software - MCR/PI-CONF-WIN - 2814799

PI/MCR configuration software for programming PI-EX-RTD..., PI-EX-TC..., MCR-T..., MCR-PSP..., MCR-f..., and MCR-S... modules. This software is available to download free of charge at - phoenixcontact.com.



Programming adapter

Programming adapter - MCR-PAC-T-USB - 2309000

Software adapter cable, 2.4 m for programming MCR-...-LP-...- and MCR-...-HT-... modules



Temperature measuring transducer - MCR-SL-PT100-LP-I - 2864558

Accessories

Adapter cable - MCR-PAC-T - 2864590



Software adapter cable, 2.4 m for programming MCR-...-LP-...- and MCR-...-HT-... modules

Drawings

Dimensioned drawing

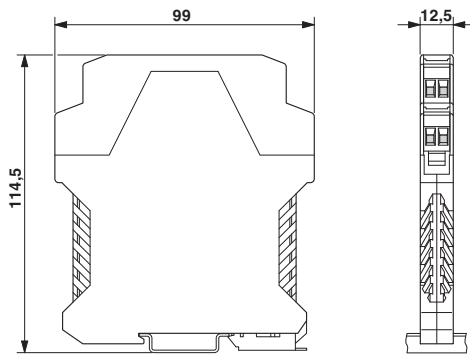

Circuit diagram

