

**EA2532QA08-16.000M TR** [Click part number to visit Part Number Details page](#)
**REGULATORY COMPLIANCE** (Data Sheet downloaded on Dec 15, 2019)

[Click badges to download compliance docs](#)

Regulatory Compliance standards are subject to updates by governing bodies. Click the badges to download the latest compliance docs for this part number directly from Ecliptek.

**ITEM DESCRIPTION**

Quartz Crystal Resonator 2.5mm x 3.2mm x 0.8mm 4 Pad Ceramic Surface Mount (SMD) 16.000MHz  $\pm 15$ ppm at 25°C,  $\pm 20$ ppm over -40°C to +85°C 08pF Parallel Resonant

**ELECTRICAL SPECIFICATIONS**

Nominal Frequency	16.000MHz
Frequency Tolerance/Stability	$\pm 15$ ppm at 25°C, $\pm 20$ ppm over -40°C to +85°C
Aging at 25°C	$\pm 3$ ppm/Year Maximum
Load Capacitance	08pF Parallel Resonant
Shunt Capacitance (C0)	5pF Maximum
Equivalent Series Resistance	80 Ohms Maximum
Mode of Operation	AT-Cut Fundamental
Drive Level	100 $\mu$ Watts Maximum
Crystal Cut	AT-Cut
Spurious Response	-3dB Minimum (Measured from Fo to Fo +5000ppm)
Storage Temperature Range	-40°C to +150°C
Insulation Resistance	500 Megaohms Minimum (Measured at 100Vdc)

**ENVIRONMENTAL & MECHANICAL SPECIFICATIONS**

ESD Susceptibility	MIL-STD-883, Method 3015, Class 1, HBM: 1500V
Fine Leak Test	MIL-STD-883, Method 1014, Condition A
Flammability	UL94-V0
Gross Leak Test	MIL-STD-883, Method 1014, Condition C
Mechanical Shock	MIL-STD-883, Method 2002, Condition B
Moisture Resistance	MIL-STD-883, Method 1004
Moisture Sensitivity	J-STD-020, MSL 1
Resistance to Soldering Heat	MIL-STD-202, Method 210, Condition K
Resistance to Solvents	MIL-STD-202, Method 215
Solderability	MIL-STD-883, Method 2003
Temperature Cycling	MIL-STD-883, Method 1010, Condition B
Vibration	MIL-STD-883, Method 2007, Condition A

## EA2532QA08-16.000M TR [Click part number to visit Part Number Details page](#)

### MECHANICAL DIMENSIONS (all dimensions in millimeters)

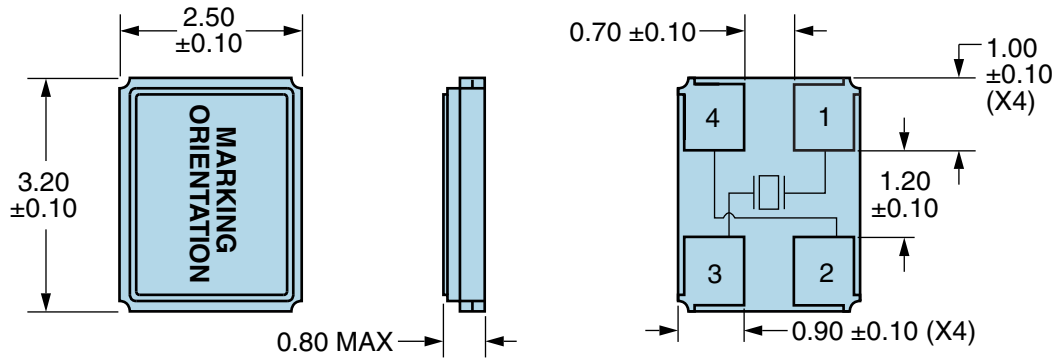

PIN	CONNECTION
1	Crystal
2	Cover/Ground
3	Crystal
4	Cover/Ground

LINE	MARKING
1	<b>E16.0</b> E=Ecliptek Designator
2	<b>XXXXX</b> XXXXX=Ecliptek Manufacturing Identifier

**Note:** Chamfer not shown.

**Seam Sealed**

**Terminal Plating Thickness:** Gold (0.3 to 1.0µm) over Nickel (1.27 to 8.89µm).

### Suggested Solder Pad Layout

All Dimensions in Millimeters

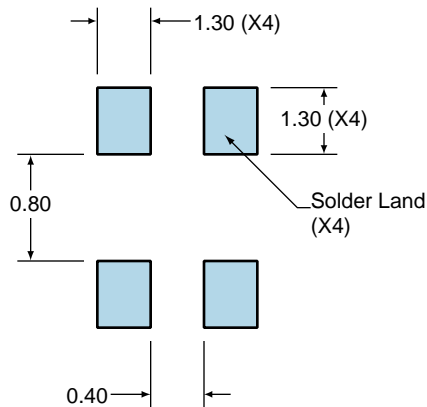

All Tolerances are ±0.1

# EA2532QA08-16.000M TR

## Tape & Reel Dimensions

Quantity Per Reel: 1,000 units

All Dimensions in Millimeters

Compliant to EIA-481

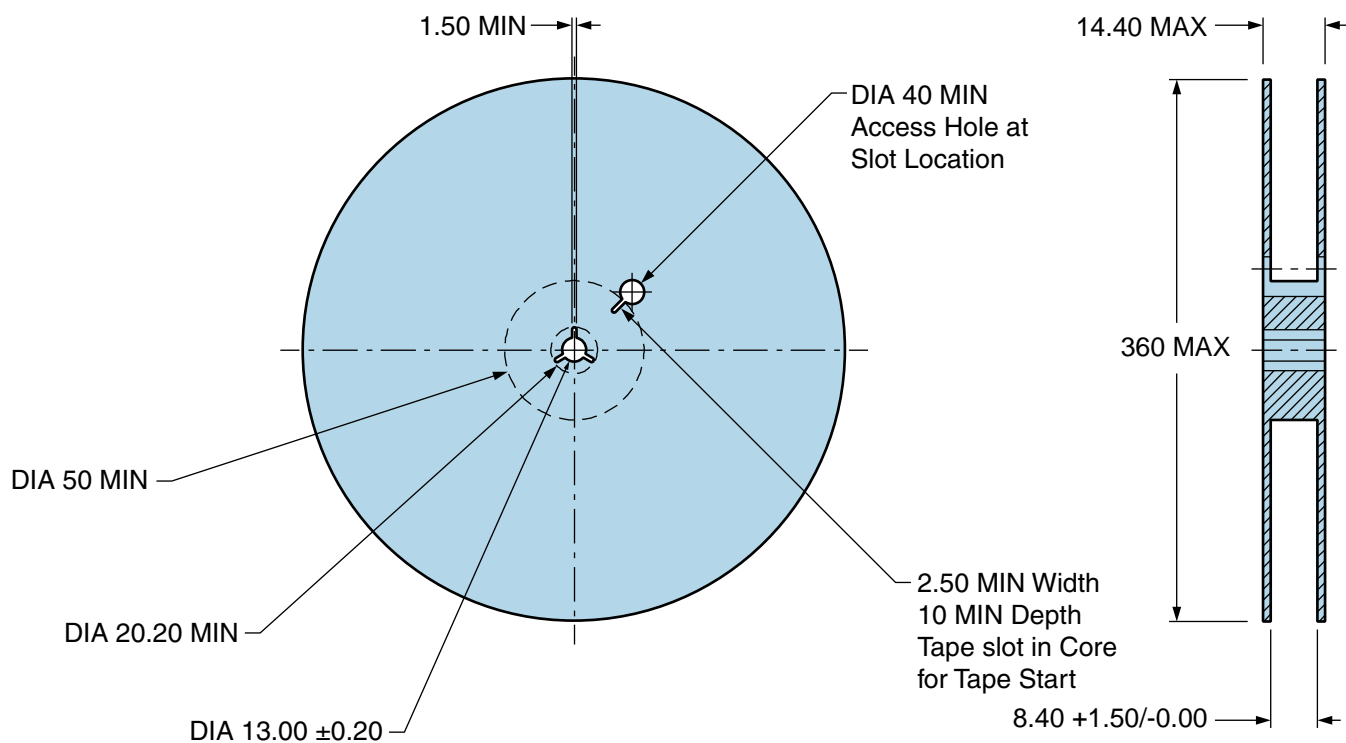
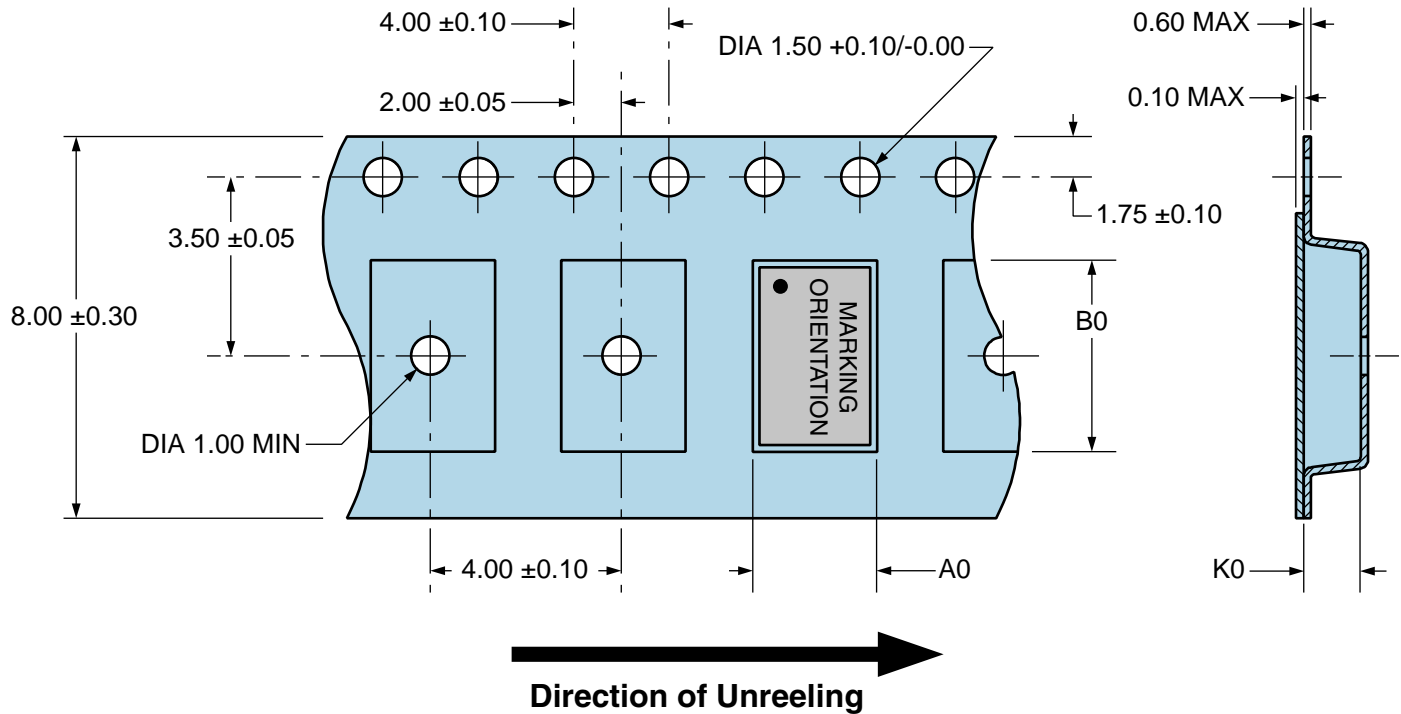

# EA2532QA08-16.000M TR [Click part number to visit Part Number Details page](#)

## Recommended Solder Reflow Methods

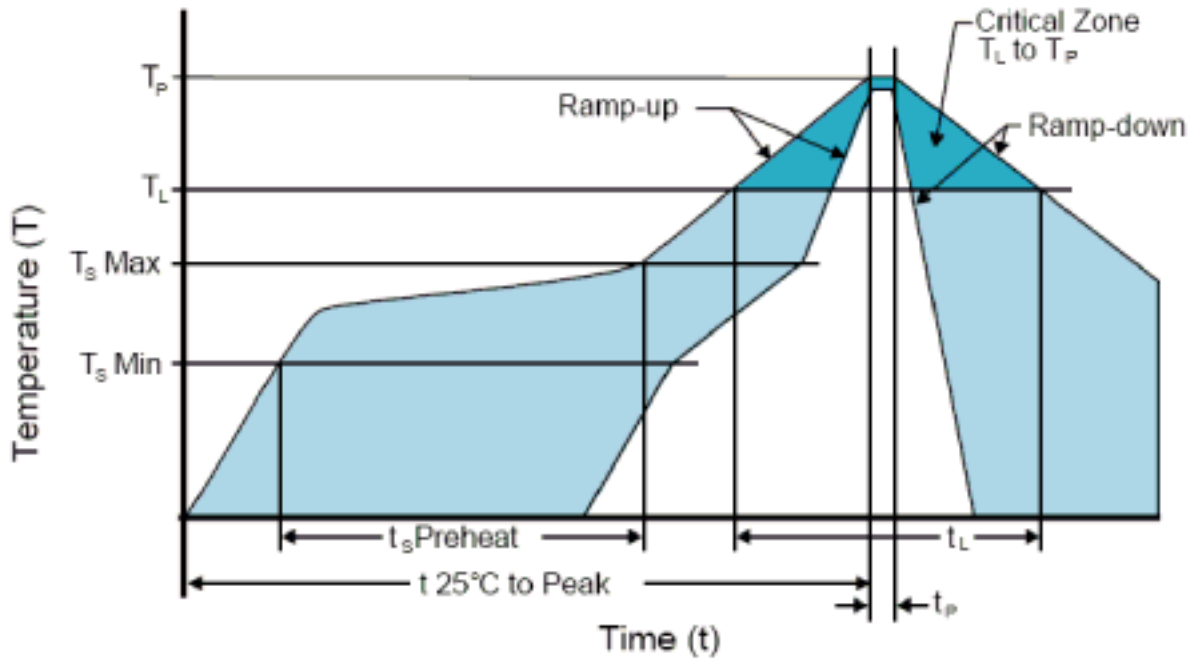

### High Temperature Infrared/Convection

<b><math>T_s</math> MAX to <math>T_L</math> (Ramp-up Rate)</b>	3°C/Second Maximum
<b>Preheat</b>	
- Temperature Minimum ( $T_s$ MIN)	150°C
- Temperature Typical ( $T_s$ TYP)	175°C
- Temperature Maximum ( $T_s$ MAX)	200°C
- Time ( $t_s$ MIN)	60 - 180 Seconds
<b>Ramp-up Rate (<math>T_L</math> to <math>T_P</math>)</b>	3°C/Second Maximum
<b>Time Maintained Above:</b>	
- Temperature ( $T_L$ )	217°C
- Time ( $t_L$ )	60 - 150 Seconds
<b>Peak Temperature (<math>T_P</math>)</b>	260°C Maximum for 10 Seconds Maximum
<b>Target Peak Temperature (<math>T_P</math> Target)</b>	250°C +0/-5°C
<b>Time within 5°C of actual peak (<math>t_p</math>)</b>	20 - 40 Seconds
<b>Ramp-down Rate</b>	6°C/Second Maximum
<b>Time 25°C to Peak Temperature (t)</b>	8 Minutes Maximum
<b>Moisture Sensitivity Level</b>	Level 1
<b>Additional Notes</b>	Temperatures shown are applied to body of device.

# EA2532QA08-16.000M TR [Click part number to visit Part Number Details page](#)

## Recommended Solder Reflow Methods



### Low Temperature Infrared/Convection 245°C

<b><math>T_S \text{ MAX}</math> to <math>T_L</math> (Ramp-up Rate)</b>	5°C/Second Maximum
<b>Preheat</b>	
- Temperature Minimum ( $T_S \text{ MIN}$ )	N/A
- Temperature Typical ( $T_S \text{ TYP}$ )	150°C
- Temperature Maximum ( $T_S \text{ MAX}$ )	N/A
- Time ( $t_s \text{ MIN}$ )	30 - 60 Seconds
<b>Ramp-up Rate (<math>T_L</math> to <math>T_P</math>)</b>	5°C/Second Maximum
<b>Time Maintained Above:</b>	
- Temperature ( $T_L$ )	150°C
- Time ( $t_L$ )	200 Seconds Maximum
<b>Peak Temperature (<math>T_P</math>)</b>	245°C Maximum
<b>Target Peak Temperature (<math>T_P \text{ Target}</math>)</b>	245°C Maximum 2 Times / 230°C Maximum 1 Time
<b>Time within 5°C of actual peak (<math>t_p</math>)</b>	10 Seconds Maximum 2 Times / 80 Seconds Maximum 1 Time
<b>Ramp-down Rate</b>	5°C/Second Maximum
<b>Time 25°C to Peak Temperature (t)</b>	N/A
<b>Moisture Sensitivity Level</b>	Level 1
<b>Additional Notes</b>	Temperatures shown are applied to body of device.

### Low Temperature Manual Soldering

185°C Maximum for 10 Seconds Maximum, 2 times Maximum. (Temperatures shown are applied to body of device.)

### High Temperature Manual Soldering

260°C Maximum for 5 Seconds Maximum, 2 times Maximum. (Temperatures shown are applied to body of device.)