

REL-IR2/L-120AC/2X21

Order No.: 2903667

The figure shows version REL-IR2/LDP- 24DC/2X21



<http://catalog.phoenixcontact.net/phoenix/treeViewClick.do?UID=2903667>

Plug-in industrial relay with power contacts, 2 PDTs, test key, status LED, mechanical switch position indicator, input voltage: 120 V AC

Commercial data	
EAN	4 046356 758208 
sales group	G082
Pack	10 Pcs.
Customs tariff	85364900
Gross weight in pieces	0.03641 KG
Net weight per piece	0.03641 KG
Catalog page information	Page 292 (C-7-2013)

Product notes

WEEE/RoHS-compliant since:
07/03/2012



<http://www.download.phoenixcontact.com>
Please note that the data given here has been taken from the online catalog. For comprehensive information and data, please refer to the user documentation. The General Terms and Conditions of Use apply to Internet downloads.

Technical data	
Dimensions	
Width	21.2 mm
Height	35.6 mm
Depth	27.5 mm
Ambient conditions	
Ambient temperature (operation)	-40 °C ... 55 °C

Ambient temperature (storage/transport)	-40 °C ... 85 °C
Coil side	
Nominal input voltage U_N	120 V AC
Input voltage range in reference to U_N	see diagram
Typical input current at U_N	13 mA
Typical response time	5 ms ... 15 ms (depending on phase relation)
Typical release time range	5 ms ... 20 ms (depending on phase relation)
Status display	Yellow LED
Contact side	
Contact type	2 PDT
Contact material	AgNi
Maximum switching voltage	250 V AC/DC
Minimum switching voltage	5 V (At 24 mA)
Maximum inrush current	30 A (20 ms, N/O contact)
Min. switching current	5 mA (at 24 V)
Limiting continuous current	12 A
Interrupting rating (ohmic load) max.	288 W (at 24 V DC)
	124 W (at 48 V DC)
	108 W (at 60 V DC)
	52 W (at 110 V DC)
	48 W (at 220 V DC)
	3000 VA (for 250 V AC)
Switching capacity min.	0.12 W
Switching capacity in acc. with DIN VDE 0660/IEC 60947	2 A (at 24 V, DC13)
	0.22 A (at 120 V, DC13)
	0.11 A (at 250 V, DC13)
	3 A (at 120 V, AC15)
	1.5 A (at 240 V, AC15)
General	
Test voltage relay winding/relay contact	2.5 kV _{rms} (50 Hz, 1 min.)
Test voltage relay contact/relay contact	2.5 kV _{rms} (50 Hz, 1 min.)
Test voltage PDT/PDT	2.5 kV _{rms} (50 Hz, 1 min.)
Operating mode	100% operating factor

Degree of protection	RT I
Mechanical service life	Approx. 2×10^7 cycles
Designation	Air and creepage distances between the power circuits
Standards/regulations	IEC 61810
Rated insulation voltage	250 V AC
Pollution degree	3
Surge voltage category	III
Designation	Standards/regulations
Standards/regulations	IEC 61810
Mounting position	any
Connection data	
Connection method	Plug connection

Certificates / Approvals



Certification CSA, cULus Recognized, VDE Zeichengenehmigung

Certifications applied for:

Certification Ex:

Accessories

Item	Designation	Description
Relay base		
2900934	RIF-2-BPT/4X21	RIF-2... relay base, for industrial relay with 2 or 4 PDTs, push-in connection, plug-in option for input/suppressor modules, for mounting on NS 35/7,5

Drawings

Diagram

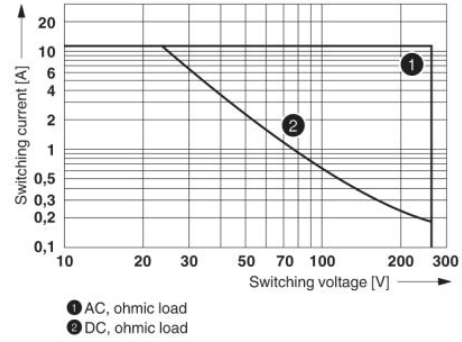
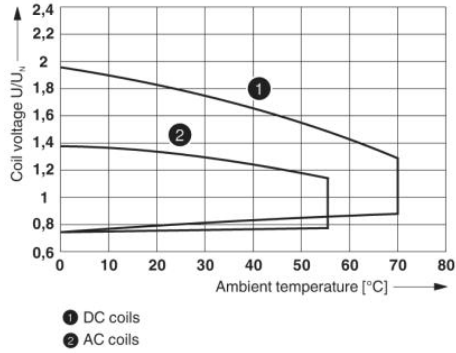

Operating voltage range

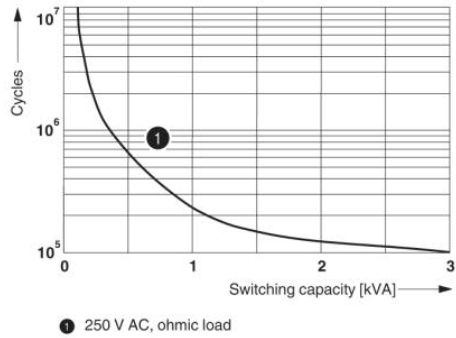

Interrupting rating

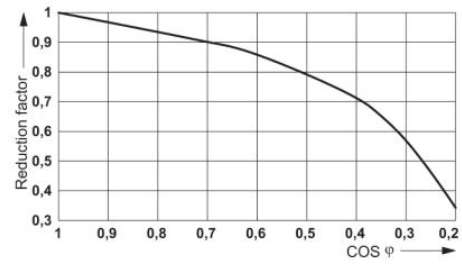

Service life reduction factor

Electrical service life

Circuit diagram

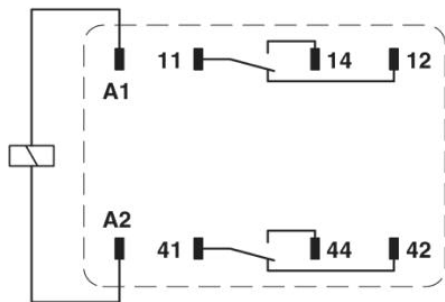

Address

PHOENIX CONTACT Deutschland GmbH
Flachmarktstr. 8
32825 Blomberg, Germany
Phone +49 5235 3 12000
Fax +49 5235 3 41200
<http://www.phoenixcontact.com>



© 2014 Phoenix Contact
Technical modifications reserved;