

Safety relays - PSR-MC32-3NO-1NC-24-230UC-SP - 2700525

Please be informed that the data shown in this PDF Document is generated from our Online Catalog. Please find the complete data in the user's documentation. Our General Terms of Use for Downloads are valid (<http://phoenixcontact.com/download>)



Safety relay for emergency stop, safety doors and light grids up to SILCL 3, Cat. 4, PL e, 1 or 2-channel operation, automatic or manual, monitored start, 3 enabling current paths, 1 signaling current path, $U_s = 24 \dots 230 \text{ V AC/DC}$, pluggable Push-in terminal block

The figure shows a version with a screw connection

Your advantages

- Up to Cat.4/PL e according to ISO 13849-1, SILCL 3 according to IEC 62061
- One or two-channel activation
- 3 enabling current paths, 1 signaling current path
- Manually monitored and automatic activation in a single device
- Cross-circuit detection
- Time saving push-in connection, tools not required
- Potentials can be easily looped through – ideal for BUS applications
- Intuitive use through colour coded actuation lever
- Can be combined with the MSTB 2,5 range
- Quick and convenient testing using integrated test option



Key Commercial Data

Packing unit	1 pc
GTIN	 4 046356 912709
GTIN	4046356912709
Weight per Piece (excluding packing)	235.400 g
Custom tariff number	85371098
Country of origin	Germany

Technical data

Note

Safety relays - PSR-MC32-3NO-1NC-24-230UC-SP - 2700525

Technical data

Note

Utilization restriction	EMC: class A product, see manufacturer's declaration in the download area
-------------------------	---

Dimensions

Width	22.5 mm
Height	117.4 mm
Depth	114.5 mm

Ambient conditions

Ambient temperature (operation)	-40 °C ... 55 °C (observe derating)
Ambient temperature (storage/transport)	-40 °C ... 85 °C
Max. permissible relative humidity (operation)	75 % (on average, 85% infrequently, non-condensing)
Max. permissible humidity (storage/transport)	75 % (on average, 85% infrequently, non-condensing)
Maximum altitude	≤ 2000 m (Above sea level)

Power supply

Designation	A1/A2
Rated control circuit supply voltage U_s	24 V AC/DC ... 230 V AC/DC -15 % / +10 %
Rated control supply current I_s	typ. 103 mA (24 V DC)
	typ. 47 mA (48 V DC)
	typ. 38 mA (110 V AC)
	typ. 21 mA (230 V AC)
Power consumption at U_s	2.7 W (with DC)
	2.9 W (with AC)
Apparent power	typ. 5 VA (at U_s)
Inrush current	< 80 A ($\Delta t = 50 \mu s$ at U_s)
Filter time	2 ms (at A1 in the event of voltage dips at U_s)
Protective circuit	U_s : surge protection 275 V varistor / 411 V suppressor diode

Digital inputs

Input name	Sensor circuit
	S10, S11, S12, S13, S21, S22
Description of the input	safety-related sensor inputs
Input voltage range "0" signal	0 V DC ... 5 V DC (for safe Off; at S10/S12/S13)
Input current range "0" signal	0 mA ... 2 mA (for safe Off; at S10/S12/S13)
Inrush current	< 5 mA (with U_s/I_x at S10/S12/S13)
	> -5 mA (with U_s/I_x to S22)
Current consumption	< 5 mA (with U_s/I_x at S10/S12/S13)
	> -5 mA (with U_s/I_x to S22)
Filter time	max. 1.5 ms (to S10-S12; test pulse width; at 24 V DC)
	7.5 ms (to S10-S12; test pulse rate; at 24 V DC)
	Test pulse rate = 5 x Test pulse width
Max. permissible overall conductor resistance	150 Ω

Safety relays - PSR-MC32-3NO-1NC-24-230UC-SP - 2700525

Technical data

Digital inputs

Concurrence input 1/2	∞
Type of protection	Inputs: protection against polarity reversal, surge protection
Protective circuit/component	38.6 V suppressor diode
Input name	Start circuit
	S34, S35
Description of the input	non-safety-related
	NPN
Number of inputs	2
Inrush current	< 10 mA ($\Delta t = 330 \text{ ms}$)
Current consumption	typ. 2.5 mA (S34)
	typ. 1 mA (S35)
Max. permissible overall conductor resistance	150 Ω
Protective circuit/component	Suppressor diode

Relay outputs: enabling current path

Output name	Enabling current paths
	13/14, 23/24, 33/34
Output description	safety-related N/O contacts
Number of outputs	3 (undelayed)
Contact type	3 enabling current paths
Contact material	AgSnO ₂
Switching voltage	min. 5 V AC/DC
	max. 250 V AC/DC (Observe the load curve)
Limiting continuous current	6 A (observe derating)
Inrush current	min. 10 mA
	max. 6 A
Sq. Total current	72 A ² (observe derating)
Switching capacity	min. 50 mW
Switching frequency	max. 1 Hz
Interrupting rating (ohmic load) max.	1500 VA (250 V AC, $\tau = 0 \text{ ms}$)
	For additional values, see load curve
Maximum interrupting rating (inductive load)	48 W (24 V DC, $\tau = 40 \text{ ms}$)
	40 W (48 V DC, $\tau = 40 \text{ ms}$)
	36 W (60 V DC, $\tau = 40 \text{ ms}$)
	35 W (110 V DC, $\tau = 40 \text{ ms}$)
	33 W (220 V DC, $\tau = 40 \text{ ms}$)
	1500 VA (250 V AC, $\tau = 40 \text{ ms}$)
Mechanical service life	10x 10 ⁶ cycles
Switching capacity according to IEC 60947-5-1	5 A (24 V (DC13))
	5 A (250 V (AC15))
Output fuse	6 A gL/gG

Safety relays - PSR-MC32-3NO-1NC-24-230UC-SP - 2700525

Technical data

Relay outputs: enabling current path

	4 A gL/gG (for low-demand applications)
--	---

Relay outputs: return current/signaling current path

Output name	Signaling current path
Output description	non-safety-related N/C contact
Number of outputs	1 (undelayed)
Contact type	1 signaling current path
Contact material	AgSnO ₂
Switching voltage	min. 5 V AC/DC
	max. 250 V AC/DC
Limiting continuous current	6 A
Inrush current	min. 10 mA
	max. 6 A
Switching capacity	min. 50 mW
Switching frequency	1 Hz
Mechanical service life	10x 10 ⁶ cycles
Output fuse	6 A gL/gG
	4 A gL/gG (for low-demand applications)

Times

Typical pickup time at US	< 200 ms (when controlled via A1)
Typical response time at US	< 150 ms (automatic start)
	< 100 ms (manual, monitored start)
Typical release time at US	< 20 ms (when actuation is via the sensor circuit)
Restart time	< 1 s
Recovery time	< 500 ms

General

Relay type	Electromechanical relay with forcibly guided contacts in accordance with EN 50205
Nominal operating mode	100% operating factor
Net weight	235.4 g
Mounting position	vertical or horizontal
Mounting type	DIN rail mounting
Assembly instructions	See derating curve
Degree of protection	IP20
Min. degree of protection of inst. location	IP54
Housing material	PBT
Housing color	yellow
Operating voltage display	1 x green LED
Status display	3 x green LED

Connection capacity

Safety relays - PSR-MC32-3NO-1NC-24-230UC-SP - 2700525

Technical data

Connection capacity

Connection method	Push-in spring connection
pluggable	Yes
Conductor cross section solid	0.2 mm ² ... 1.5 mm ²
Conductor cross section flexible	0.2 mm ² ... 1.5 mm ²
Conductor cross section AWG / kcmil	24 ... 16
Conductor cross section flexible, with ferrule without plastic sleeve	0.25 mm ² ... 1.5 mm ² (only together with CRIMPFOX 6)
Conductor cross section, flexible, with ferrule, with plastic sleeve	0.25 mm ² ... 1.5 mm ² (only together with CRIMPFOX 6)
Stripping length	8 mm

Safety-related characteristic data

Stop category	0
Designation	IEC 61508 - High demand
Safety Integrity Level (SIL)	3
Designation	IEC 61508 - Low demand
Safety Integrity Level (SIL)	3
Designation	EN ISO 13849
Performance level (PL)	e
Category	4 (5 A DC13; 5 A AC15; 8760 switching cycles/year)
Designation	EN 62061
Safety Integrity Level Claim Limit (SIL CL)	3

Standards and Regulations

Designation	Air clearances and creepage distances between the power circuits
Standards/regulations	DIN EN 50178; EN 60947-5-1
Rated insulation voltage	250 V AC
Rated surge voltage/insulation	Basic insulation 4 kV between enabling current path (23/24) and enabling current path (33/34) and signaling current path (41/42)
	Basic insulation 4 kV between all current paths and housing
	Safe isolation, reinforced insulation 6 kV between all other circuits
Degree of pollution	2
Overvoltage category	III
Shock	15g
Vibration (operation)	10 Hz ... 150 Hz, 2g
Conformance	CE-compliant

Environmental Product Compliance

REACH SVHC	Lead 7439-92-1
China RoHS	Environmentally Friendly Use Period = 50
	For details about hazardous substances go to tab "Downloads", Category "Manufacturer's declaration"

Drawings

Safety relays - PSR-MC32-3NO-1NC-24-230UC-SP - 2700525

Block diagram

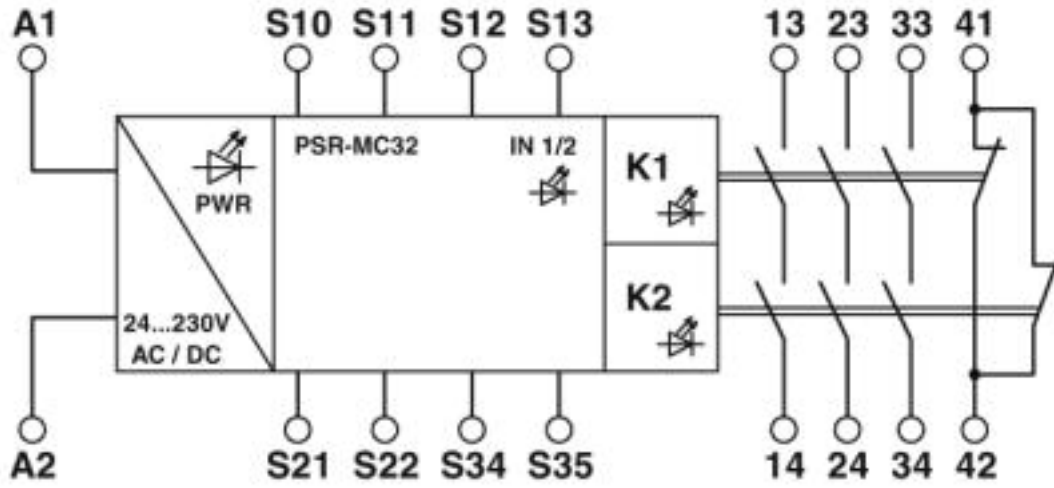

Safety relays - PSR-MC32-3NO-1NC-24-230UC-SP - 2700525

Circuit diagram

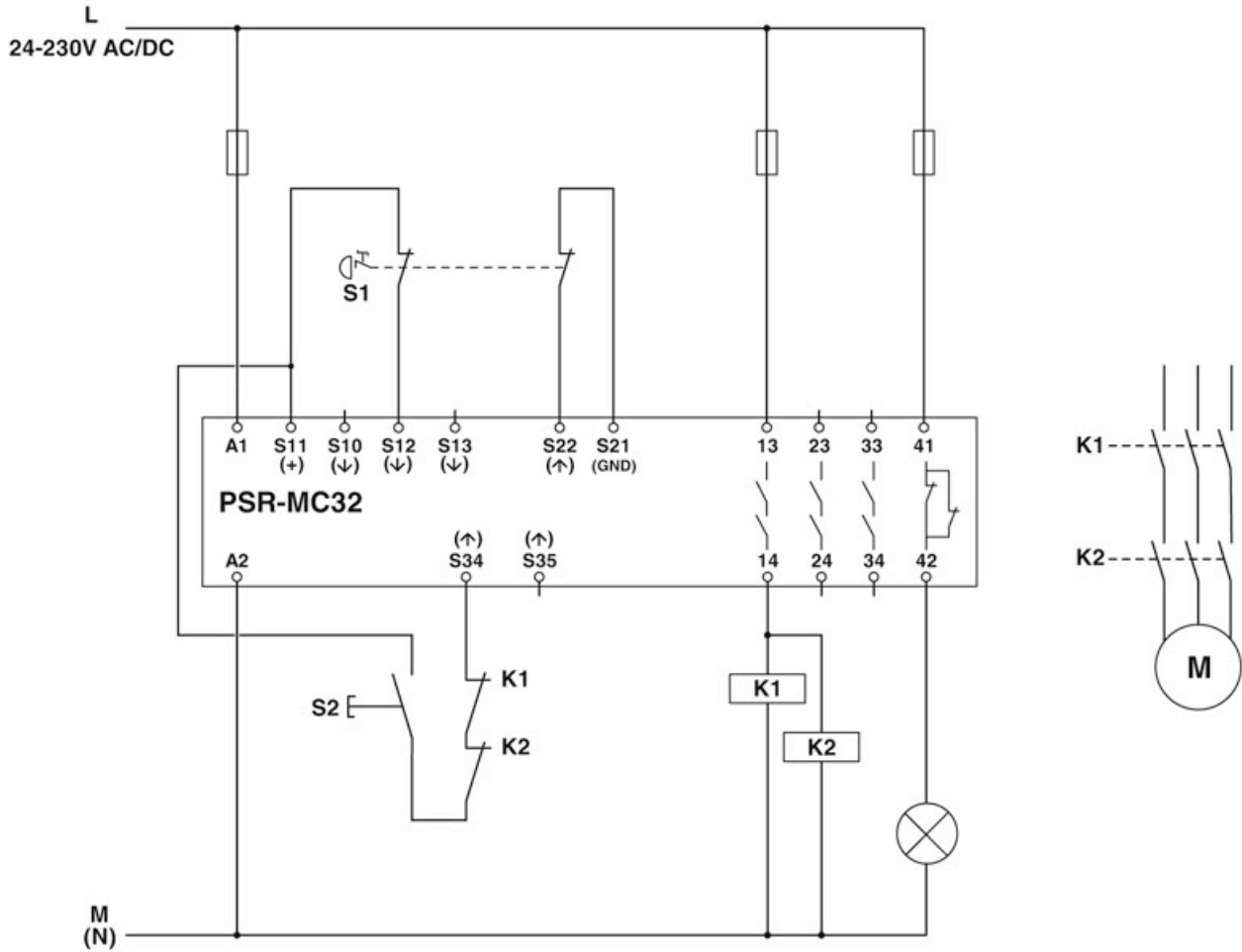

Safety relays - PSR-MC32-3NO-1NC-24-230UC-SP - 2700525

Classifications

eCl@ss

eCl@ss 4.0	40020600
eCl@ss 4.1	40020600
eCl@ss 5.0	27371900
eCl@ss 5.1	27371900
eCl@ss 6.0	27371800
eCl@ss 7.0	27371819
eCl@ss 8.0	27371819
eCl@ss 9.0	27371819

ETIM

ETIM 3.0	EC001449
ETIM 4.0	EC001449
ETIM 5.0	EC001449
ETIM 6.0	EC001449
ETIM 7.0	EC001449

UNSPSC

UNSPSC 13.2	39121501
UNSPSC 18.0	39122205
UNSPSC 19.0	39122205
UNSPSC 20.0	39122205
UNSPSC 21.0	39122205

Approvals

Approvals

Approvals

UL Listed / cUL Listed / Functional Safety / cULus Listed

Ex Approvals

Approval details

UL Listed		http://database.ul.com/cgi-bin/XYV/template/LISEXT/1FRAME/index.htm	FILE E 140324
-----------	--	---	---------------

Safety relays - PSR-MC32-3NO-1NC-24-230UC-SP - 2700525

Approvals

cUL Listed		http://database.ul.com/cgi-bin/XYV/template/LISEXT/1FRAME/index.htm	FILE E 140324
------------	---	---	---------------

Functional Safety			44-205-15124310
-------------------	---	--	-----------------

cULus Listed			
--------------	---	--	--