

# NFL25065L4BT

## SPM<sup>®</sup> 2 32 Series Intelligent Power Module (IPM) Interleaved PFC, 650 V, 50 A

The NFL25065L4BT is a Motion SPM 2 module providing a fully-featured, high-performance Interleaved PFC (Power Factor Correction) input power stage for consumer, medical, and industrial applications. These modules integrate optimized gate drive of the built-in IGBTs to minimize EMI and losses, while also providing multiple on-module protection features including under-voltage lockout, over-current shutdown, thermal monitoring, and fault reporting. These modules also feature a full-wave rectifier and high-performance output diodes for additional space savings and mounting convenience.

### Features

- UL Certified No. E209024 (UL1557)
- 650 V – 50 A 2-Phase Interleaved PFC with Integral Gate Drivers and Protection
- Very Low Thermal Resistance using Al<sub>2</sub>O<sub>3</sub> DBC Substrate
- Low-Loss Field Stop 4<sup>th</sup> Generation IGBT
- Full-Wave Bridge Rectifier and High-Performance Output SiC Boost Diode
- Optimized for 20 kHz Switching Frequency
- Built-in NTC Thermistor for Temperature Monitoring
- Isolation Rating of 2500 Vrms / 1 min
- These Devices are RoHS Compliant

### Typical Applications

- 2-Phase Interleaved PFC Converter (AC 200V Class)
  - ◆ HVAC (Commercial Air-conditioner)

### Integrated Power Functions

- 650 V – 50 A 2-Phase Interleaved PFC for Single-phase AC / DC Power Conversion (refer to Figure 2)

### Integrated Drive, Protection, and System Control Functions

- For IGBTs: Gate-drive Circuit, Over-Current Protection (OCP) Control Circuit, Under-Voltage Lock-Out Protection (UVLO)
- Fault Signaling: Corresponding to UV and OC faults
- Built-in Thermistor: Temperature Monitoring
- Input Interface: Active-HIGH Interface, works with 3.3 V / 5 V Logic, Schmitt-Trigger Input



ON Semiconductor<sup>®</sup>

[www.onsemi.com](http://www.onsemi.com)

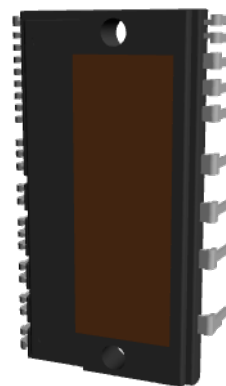

3D Package Drawing  
(Click to Activate 3D Content)

S32EA-032  
CASE MODEB

### MARKING DIAGRAM

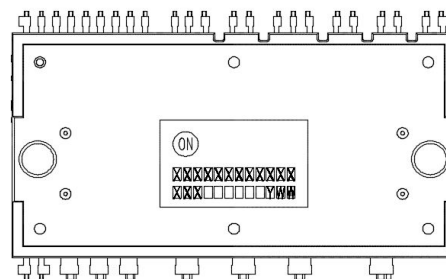

ON	= ON Semiconductor Logo
NFL25065L4BT	= Specific Device Code
XXX	= Lot Number
Y	= Year
WW	= Work Week

### ORDERING INFORMATION

See detailed ordering and shipping information on page 7 of this data sheet.

# NFL25065L4BT

## PIN CONFIGURATION

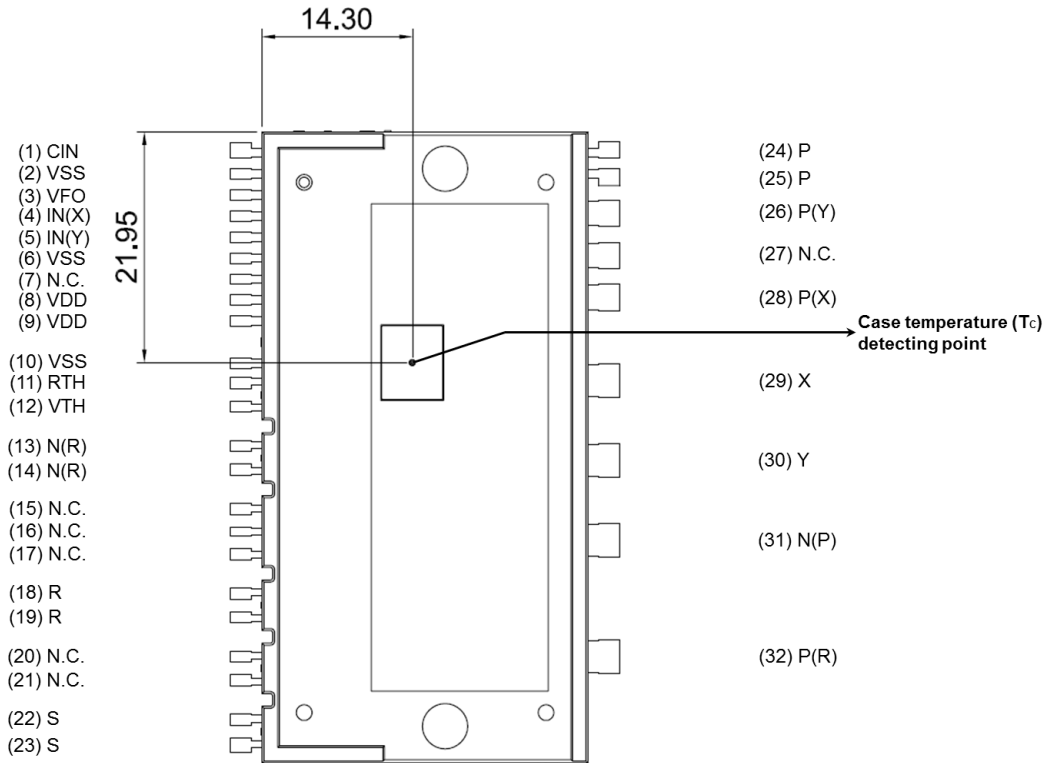

Figure 1. Pin Configuration – Top View

## INTERNAL EQUIVALENT CIRCUIT AND INPUT/OUTPUT PINS

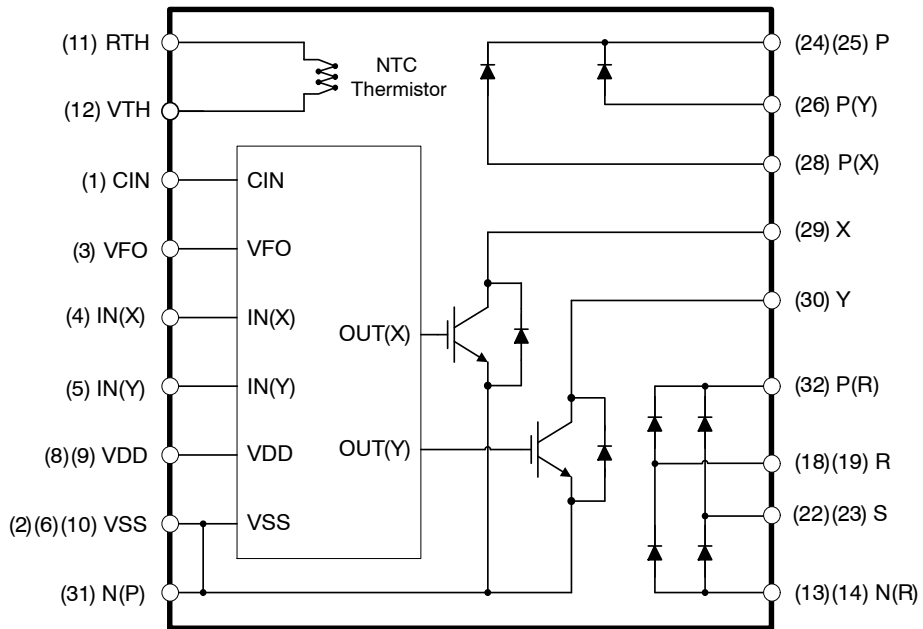

Figure 2. Internal Block Diagram

## NFL25065L4BT

**Table 1. PIN DESCRIPTION**

Pin Number	Pin Name	Pin Description
1	CIN	Signal Input for Over-Current Detection
2, 6, 10	VSS	Common Supply Ground
3	VFO	Fault Output
4	IN(X)	PWM Input for X IGBT Drive
5	IN(Y)	PWM Input for Y IGBT Drive
7	N.C.	No Connection
8, 9	VDD	Supply Bias Voltage of IC for IGBT Driving
11	RTH	Series Resistor for The Use of Thermistor
12	VTH	Thermistor Bias Voltage
13, 14	N(R)	Negative DC-Link of Rectifier Diode
15, 16, 17	N.C.	No Connection
18, 19	R	AC Input for R-Phase
20, 21	N.C.	No Connection
22, 23	S	AC Input for S-Phase
24, 25	P	Output of Boost Diode
26	P(Y)	Input of Boost Diode
27	N.C.	No Connection
28	P(X)	Input of Boost Diode
29	X	Output of X Phase IGBT
30	Y	Output of Y Phase IGBT
31	N(P)	Negative DC-Link of IGBT
32	P(R)	Positive DC-Link of Rectifier Diode

# NFL25065L4BT

**Table 2. ABSOLUTE MAXIMUM RATINGS** ( $T_J = 25^\circ\text{C}$  unless otherwise noted)

Symbol	Parameter	Conditions	Rating	Unit
<b>CONVERTER PART</b>				
$V_i$	Input Supply Voltage	Applied between R – S	264	Vrms
VPN	Output Voltage	Applied between X – N(P), Y – N(P), P – P(X), P – P(Y)	450	V
VPN(Surge)	Supply Voltage (Surge)	Applied between X – N(P), Y – N(P), P – P(X), P – P(Y)	500	V
VCES	Collector - Emitter Voltage	Breakdown Voltage between X – N(P), Y – N(P)	650	V
VRRM	Repetitive Peak Reverse Voltage of Boost Diode	Breakdown Voltage between P – P(X), P – P(Y)	650	V
VRRMR	Repetitive Peak Reverse Voltage of Rectifier	Breakdown Voltage between P(R) – R, P(R) – S, R – N(R), S – N(R)	900	V
IF	Boost Diode Forward Current	$T_c = 25^\circ\text{C}$ , $T_j \leq 150^\circ\text{C}$ (Note 1)	50	A
IFSM	Peak Surge Current of Boost Diode	Non-Repetitive, 60 Hz Single Half-Sine Wave (Note 1)	150	A
IFR	Rectified Forward Current	$T_c = 25^\circ\text{C}$ , $T_j \leq 150^\circ\text{C}$ (Note 1)	50	A
IFSMR	Peak Surge Current of Rectifier	Non-Repetitive, 60 Hz Single Half-Sine Wave (Note 1)	500	A
$\pm I_c$	Each IGBT Collector Current	$T_c = 25^\circ\text{C}$ , $T_j \leq 150^\circ\text{C}$ (Note 1)	50	A
$\pm I_{cp}$	Each IGBT Collector Current (Peak)	$T_c = 25^\circ\text{C}$ , $T_j \leq 150^\circ\text{C}$ , Under 1 ms Pulse Width (Note 1)	100	A
Pc	Collector Dissipation	$T_c = 25^\circ\text{C}$ per IGBT (Note 1)	125	W
$T_j$	Operating Junction Temperature		-40 ~ 150	$^\circ\text{C}$

## CONTROL PART

VDD	Control Supply Voltage	Applied between VDD – VSS	20	V
VIN	Input Signal Voltage	Applied between IN(X), IN(Y) – VSS	-0.3 ~ VDD + 0.3	V
VFO	Fault Output Supply Voltage	Applied between VFO – VSS	-0.3 ~ VDD + 0.3	V
IFO	Fault Output Current	Sink Current at VFO pin	1	mA
VCIN	Current Sensing Input Voltage	Applied between CIN – VSS	-0.3 ~ VDD + 0.3	V
$T_j$	Operating Junction Temperature		-40 ~ 150	$^\circ\text{C}$

## TOTAL SYSTEM

$T_c$	Module Case Operation Temperature	See Figure 1	-40 ~ 125	$^\circ\text{C}$
Tstg	Storage Temperature		-40 ~ 125	$^\circ\text{C}$
Viso	Isolation Voltage	60 Hz, Sinusoidal, AC 1 Minute, Connection Pins to Heat Sink Plate	2500	Vrms

Stresses exceeding those listed in the Maximum Ratings table may damage the device. If any of these limits are exceeded, device functionality should not be assumed, damage may occur and reliability may be affected.

1. These values had been made an acquisition by the calculation considered to design factor.

**Table 3. THERMAL RESISTANCE**

Symbol	Parameter	Conditions	Min	Typ	Max	Unit
$R_{th(j-c)Q}$	Junction-to-Case Thermal Resistance (Note 2)	Each IGBT under Operating Condition	-	-	1.00	$^\circ\text{C}/\text{W}$
$R_{th(j-c)D}$		Each Boost Diode under Operating Condition	-	-	1.60	$^\circ\text{C}/\text{W}$
$R_{th(j-c)R}$		Each Rectifier under Operating Condition	-	-	0.74	$^\circ\text{C}/\text{W}$

2. For the measurement point of case temperature ( $T_c$ ), please refer to Figure 1. DBC discoloration and Picker Circle Printing allowed, please refer to application note AN-9190 (Impact of DBC Oxidation on SPM<sup>®</sup> Module Performance).

# NFL25065L4BT

**Table 4. ELECTRICAL CHARACTERISTICS** ( $T_J = 25^\circ\text{C}$  unless otherwise specified.)

Symbol	Parameter	Conditions	Min	Typ	Max	Unit	
<b>CONVERTER PART</b>							
VCE(sat)	Collector – Emitter Saturation Voltage	VDD = 15 V, VIN = 5 V, Ic = 50 A, Tj = 25°C	–	1.55	2.05	V	
VFWD	FWDi Forward Voltage	Ifwd = 15 A, Tj = 25°C	–	1.95	2.45	V	
VF	Boost Diode Forward Voltage	If = 50 A, Tj = 25°C	–	1.80	2.30	V	
VFR	Rectifier Forward Voltage	Ifr = 50 A, Tj = 25°C	–	1.13	1.35	V	
ton	Switching Times	VPN = 400 V, VDD = 15 V, Ic = 25 A Tj = 25°C VIN = 0 V ↔ 5 V, Inductive Load See Figure 3 (Note 3)	–	650	–	ns	
tc(on)			–	75	–	ns	
toff			–	900	–	ns	
tc(off)			–	100	–	ns	
trr			–	50	–	ns	
Irr			–	15	–	A	
ICES	Collector – Emitter Leakage Current	VCE = VCES	–	–	1	mA	
IR	Boost Diode Revers Leakage Current	VR = VRRM	–	–	1	mA	
<b>CONTROL PART</b>							
IQDD	Quiescent VDD Supply Current	VDD = 15 V, IN(X), IN(Y) – VSS = 0 V, Supply Current between VDD and VSS	–	–	2.65	mA	
IPDD	Operating VDD Supply Current	VDD = 15 V, FPWM = 20 kHz, Duty = 50%, Applied to one PWM Signal Input per IGBT, Supply Current between VDD and VSS	–	–	7.00	mA	
VFOH	Fault Output Voltage	VDD = 15 V, VFO Circuit: 10 kΩ to 5 V Pull-up	VCIN = 0 V	4.50	–	–	V
VFOL		VDD = 15 V, IFO = 1mA	VCIN = 1 V	–	–	0.50	V
VCIN(ref)	Short Circuit Trip Level	VDD = 15 V	CIN – VSS	0.45	0.50	0.55	V
UVDDD	Supply Circuit Under-Voltage Protection	Detection Level		10.5	–	13.0	V
UVDDR		Reset Level		11.0	–	13.5	V
VIN(ON)	ON Threshold Voltage	Applied between IN(X), IN(Y) – VSS		–	–	2.6	V
VIN(OFF)	OFF Threshold Voltage			0.8	–	–	V
tFOD	Fault-Out Pulse Width			30	–	–	μs
RTH	Resistance of Thermistor	at TTH = 25°C	See Figure 4 (Note 4)	–	47	–	kΩ
		at TTH = 100°C		–	2.9	–	

Product parametric performance is indicated in the Electrical Characteristics for the listed test conditions, unless otherwise noted. Product performance may not be indicated by the Electrical Characteristics if operated under different conditions.

3. ton and toff include the propagation delay of the internal drive IC. tc(on) and tc(off) are the switching times of IGBT under the given gate-driving condition internally. For the detailed information, please see Figure 3.

4. TTH is the temperature of thermistor itself. To know case temperature (Tc), conduct experiments considering the application.



# NFL25065L4BT

**Table 5. RECOMMENDED OPERATING CONDITIONS**

Symbol	Parameter	Conditions	Value			Unit
			Min	Typ	Max	
$V_i$	Input Supply Voltage	Applied between R – S	187	–	253	Vrms
$I_i$	Input Current	$T_c \leq 100^\circ\text{C}$ , $V_i = 220\text{ V}$ , $V_o = 360\text{ V}$ , FPWM = 20 kHz per IGBT	–	–	35	Arms
VPN	Supply Voltage	Applied between X – NP, Y – NP, P – PX, P – PY	–	–	400	V
VDD	Control Supply Voltage	Applied between VDD – VSS	13.5	15.0	16.5	V
dVDD / dt	Control Supply Variation		–1	–	+1	V / $\mu\text{s}$
FPWM	PWM Input Signal	$-40^\circ\text{C} \leq T_c \leq 125^\circ\text{C}$ , $-40^\circ\text{C} \leq T_j \leq 150^\circ\text{C}$	–	20	–	kHz
$T_j$	Junction Temperature		–40	–	150	$^\circ\text{C}$

Functional operation above the stresses listed in the Recommended Operating Ranges is not implied. Extended exposure to stresses beyond the Recommended Operating Ranges limits may affect device reliability.

## PACKAGE MARKING AND ORDERING INFORMATION

Device	Device Marking	Package	Shipping
NFL25065L4BT	NFL25065L4BT	S32EA-032	8 Units / Tube

## MECHANICAL CHARACTERISTICS AND RATINGS

Parameter	Conditions	Value			Unit	
		Min	Typ	Max		
Device Flatness	See Figure 5	0	–	150	$\mu\text{m}$	
Mounting Torque	Mounting Screw: M4 (Note 5, 6)	Recommended 0.98 N • m	0.78	0.98	1.17	N • m
		Recommended 10 kg • cm	8	10	12	kg • cm
Weight		–	32	–	g	

- Do not over torque when mounting screws. Too much mounting torque may cause DBC cracks, as well as bolts and Al heat-sink destruction.
- Avoid one-sided tightening stress. Uneven mounting can cause the DBC substrate of package to be damaged. The pre-screwing torque is set to 20 ~ 30% of maximum torque rating.

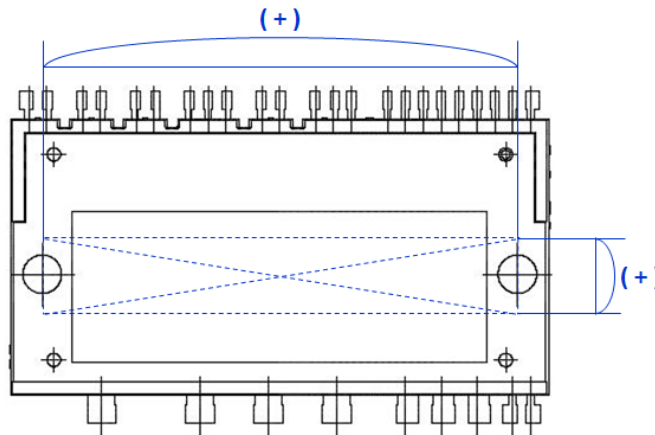

**Figure 5. Flatness Measurement Position**

TIME CHARTS OF SPMs PROTECTIVE FUNCTION

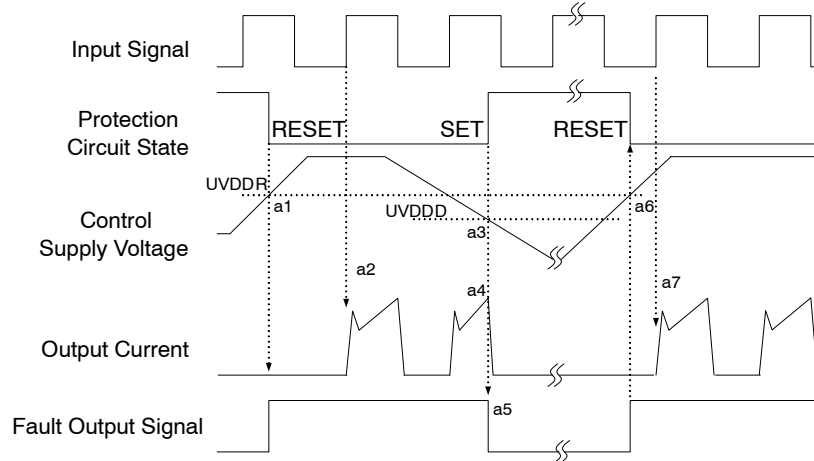

Figure 6. Under-Voltage Protection

- a1: Control supply voltage rises: after the voltage rises UVDDR, the circuits start to operate when the next input is applied.
- a2: Normal operation: IGBT ON and carrying current.
- a3: Under-voltage detection (UVDDD).
- a4: IGBT OFF in spite of control input condition.
- a5: Fault output operation starts.
- a6: Under-voltage reset (UVDDR).
- a7: Normal operation: IGBT ON and carrying current by triggering next signal from LOW to HIGH.

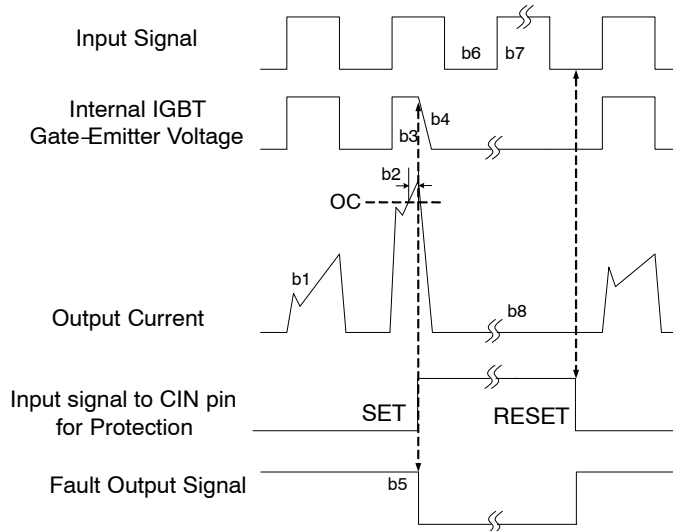
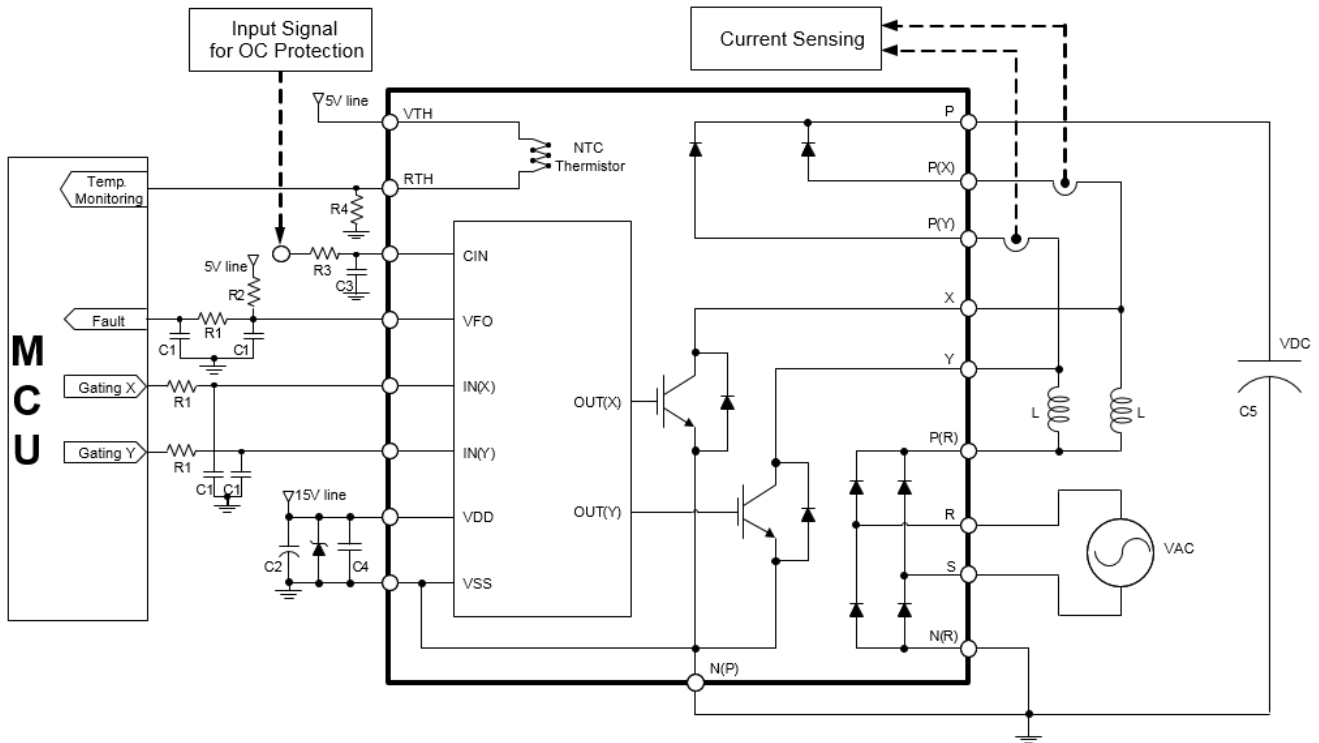

Figure 7. Over-Current Protection

- (With the external over current detection circuit)
- b1: Normal operation: IGBT ON and carrying current.
  - b2: Over-current detection (OC trigger).
  - b3: All IGBTs gate are hard interrupted.
  - b4: All IGBTs turn OFF.
  - b5: Fault output operation starts.
  - b6: Input LOW – IGBT OFF state.
  - b7: Input HIGH – IGBT ON state, but during the active period of fault output, the IGBT doesn't turn ON.
  - b8: IGBT OFF state.

# NFL25065L4BT



**Figure 8. Typical Application Circuit**

7. To avoid malfunction, the wiring of each input should be as short as possible (Less than 2 – 3 cm).
8. VFO output is an open–drain type. This signal line should be pulled up to the positive side of the MCU or control power supply with a resistor that makes IFO up to 1 mA.
9. Input signal is active–HIGH type. There is a 5 kΩ resistor inside the IC to pull–down each input signal line to GND. RC coupling circuits should be adopted for the prevention of input signal oscillation. RC coupling at each input might change depending on the PWM control scheme used in the application and the wiring impedance of the application's printed circuit board. R1C1 time constant should be selected in the range 50 ~ 150 ns (Recommended R1 = 100 Ω, C1 = 1 nF).
10. To prevent error of the protection function, the wiring related with R3 and C3 should be as short as possible.
11. In the over–current protection circuit, select the R3C3 time constant in the range 1.5 ~ 2.0 μs. Do enough evaluation on the real system because over–current protection time may vary wiring pattern layout and value of the R3C3 time constant.
12. Each capacitor should be mounted as close to the pins of the Motion SPM 2 product as possible.
13. Relays are used in most systems of electrical equipment in industrial application. In these cases, there should be sufficient distance between the MCU and the relays.
14. The zener diode or transient voltage suppressor should be adapted for the protection of ICs from the surge destruction between each pair of control supply terminals (Recommended zener diode is 22 V / 1 W, which has the lower zener impedance characteristic than about 15 Ω).
15. Please choose the electrolytic capacitor with good temperature characteristic in C2. Choose 0.1 ~ 0.2 μF R–category ceramic capacitors with good temperature and frequency characteristics in C4.

# NFL25065L4BT

## PACKAGE DIMENSIONS

S32CA-032 / 32LD, PDD STD, DBC, DIP TYPE (DBC AIN)  
CASE MODEB  
ISSUE O

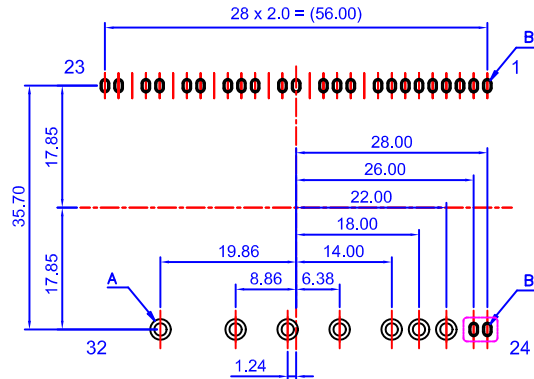
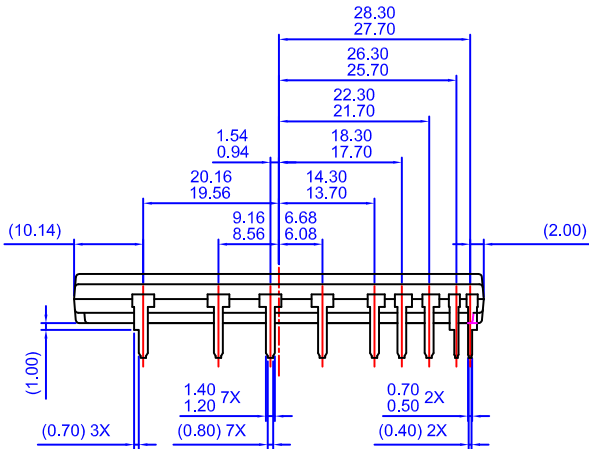
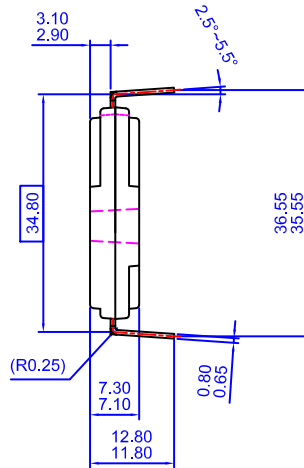
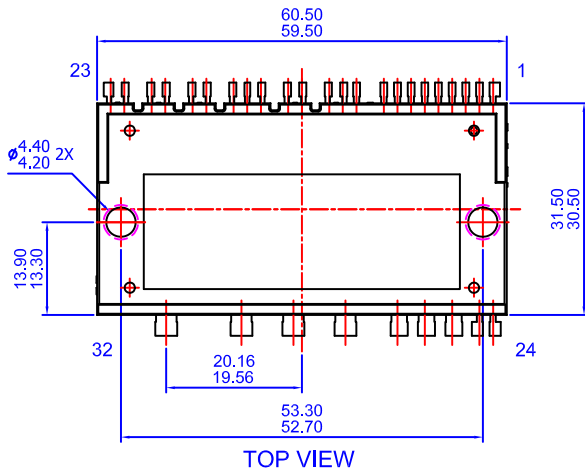
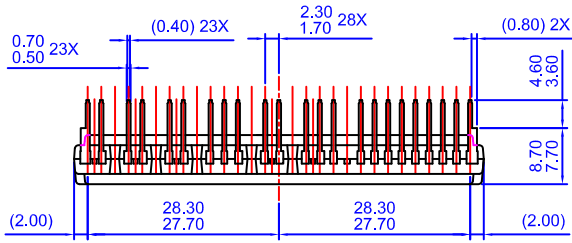

- NOTES: UNLESS OTHERWISE SPECIFIED  
A) THIS PACKAGE DOES NOT COMPLY TO ANY CURRENT PACKAGING STANDARD  
B) ALL DIMENSIONS ARE IN MILLIMETERS  
C) DIMENSIONS ARE EXCLUSIVE OF BURRS, MOLD FLASH, AND TIE BAR EXTRUSIONS  
D) ( ) IS REFERENCE

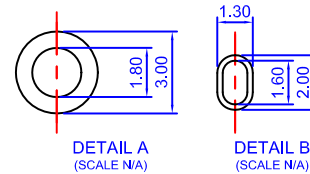

LAND PATTERN RECOMMENDATIONS

SPM is registered trademarks of Semiconductor Components Industries, LLC (SCILLC) or its subsidiaries in the United States and/or other countries.

ON Semiconductor and  are trademarks of Semiconductor Components Industries, LLC dba ON Semiconductor or its subsidiaries in the United States and/or other countries. ON Semiconductor owns the rights to a number of patents, trademarks, copyrights, trade secrets, and other intellectual property. A listing of ON Semiconductor's product/patent coverage may be accessed at [www.onsemi.com/site/pdf/Patent-Marking.pdf](http://www.onsemi.com/site/pdf/Patent-Marking.pdf). ON Semiconductor reserves the right to make changes without further notice to any products herein. ON Semiconductor makes no warranty, representation or guarantee regarding the suitability of its products for any particular purpose, nor does ON Semiconductor assume any liability arising out of the application or use of any product or circuit, and specifically disclaims any and all liability, including without limitation special, consequential or incidental damages. Buyer is responsible for its products and applications using ON Semiconductor products, including compliance with all laws, regulations and safety requirements or standards, regardless of any support or applications information provided by ON Semiconductor. "Typical" parameters which may be provided in ON Semiconductor data sheets and/or specifications can and do vary in different applications and actual performance may vary over time. All operating parameters, including "Typicals" must be validated for each customer application by customer's technical experts. ON Semiconductor does not convey any license under its patent rights nor the rights of others. ON Semiconductor products are not designed, intended, or authorized for use as a critical component in life support systems or any FDA Class 3 medical devices or medical devices with a same or similar classification in a foreign jurisdiction or any devices intended for implantation in the human body. Should Buyer purchase or use ON Semiconductor products for any such unintended or unauthorized application, Buyer shall indemnify and hold ON Semiconductor and its officers, employees, subsidiaries, affiliates, and distributors harmless against all claims, costs, damages, and expenses, and reasonable attorney fees arising out of, directly or indirectly, any claim of personal injury or death associated with such unintended or unauthorized use, even if such claim alleges that ON Semiconductor was negligent regarding the design or manufacture of the part. ON Semiconductor is an Equal Opportunity/Affirmative Action Employer. This literature is subject to all applicable copyright laws and is not for resale in any manner.

## PUBLICATION ORDERING INFORMATION

### LITERATURE FULFILLMENT:

Literature Distribution Center for ON Semiconductor  
19521 E. 32nd Pkwy, Aurora, Colorado 80011 USA  
**Phone:** 303-675-2175 or 800-344-3860 Toll Free USA/Canada  
**Fax:** 303-675-2176 or 800-344-3867 Toll Free USA/Canada  
**Email:** [orderlit@onsemi.com](mailto:orderlit@onsemi.com)

**N. American Technical Support:** 800-282-9855 Toll Free  
USA/Canada  
**Europe, Middle East and Africa Technical Support:**  
Phone: 421 33 790 2910

**ON Semiconductor Website:** [www.onsemi.com](http://www.onsemi.com)

**Order Literature:** <http://www.onsemi.com/orderlit>

For additional information, please contact your local Sales Representative