

NFAL7565L4BT

SPM 49 Series Smart Power Module (SPM) Inverter, 650 V, 75 A

General Description

The NFAL7565L4BT is a smart power module providing a fully-featured, high-performance inverter output stage for AC induction, BLDC, and PMSM motors. These modules integrate optimized gate drive of the built-in IGBTs to minimize EMI and losses, while also providing multiple on-module protection features: under-voltage lockouts, over-current shutdown, temperature sensing, and fault reporting. The built-in, high-speed HVIC requires only a single supply voltage and translates the incoming logic-level gate inputs to high-voltage, high-current drive signals to properly drive the module's internal IGBTs. Separate negative IGBT terminals are available for each phase to support the widest variety of control algorithms.

Features

- UL Certified No. 209204 (UL1557)
- 650 V – 75 A 3-Phase IGBT Inverter, Including Control ICs for Gate Drive and Protections
- Low-Loss, Short-Circuit-Rated IGBTs
- Very Low Thermal Resistance Using Al₂O₃ DBC Substrate
- Built-In Bootstrap Diodes/Resistors
- Separate Open-Emitter Pins from Low-Side IGBTs for Three-Phase Current Sensing
- Built-In NTC Thermistor for Temperature Monitoring and Management
- Adjustable Over-Current Protection via Integrated Sense-IGBTs
- Isolation Rating of 2500 Vrms/1 min
- These Devices are RoHS Compliant

Typical Applications

- Motion Control – Industrial Motor (AC 200 V Class)

Integrated Power Functions

- 650 V – 75 A IGBT Inverter for Three-Phase DC/AC Power Conversion (Refer to Figure 2)

Integrated Drive, Protection, and System Control Functions

- For Inverter High-Side IGBTs: gate-drive circuit, high-voltage isolated high-speed level-shifting control circuit, Under-Voltage Lock-Out Protection (UVLO), Available bootstrap circuit example is given in Figures 4 and 16
- For Inverter Low-Side IGBTs: gate-drive circuit, Short-Circuit Protection (SCP) control circuit, Under-Voltage Lock-Out Protection (UVLO)
- Fault Signaling: corresponding to UV (low-side supply) and SC faults
- Input Interface: active-HIGH interface, works with 3.3 V/5 V logic, Schmitt-trigger input



ON Semiconductor®

www.onsemi.com

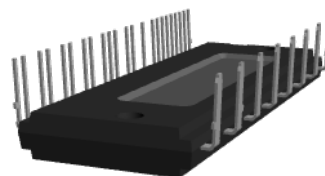

3D Package Drawing
(Click to Activate 3D Content)

SPM49-CAB
CASE MODGQ

MARKING DIAGRAM

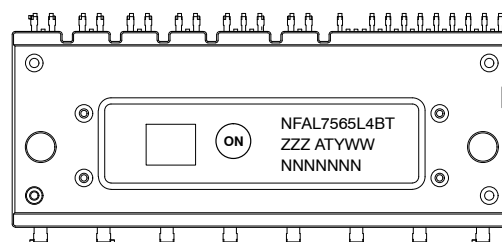

NFAL7565L4BT	= Specific Device Code
ZZZ	= Lot ID
AT	= Assembly & Test Location
Y	= Year
WW	= Work Week
NNNNNNN	= Serial Number

ORDERING INFORMATION

See detailed ordering and shipping information on page 10 of this data sheet.

NFAL7565L4BT

PIN CONFIGURATION

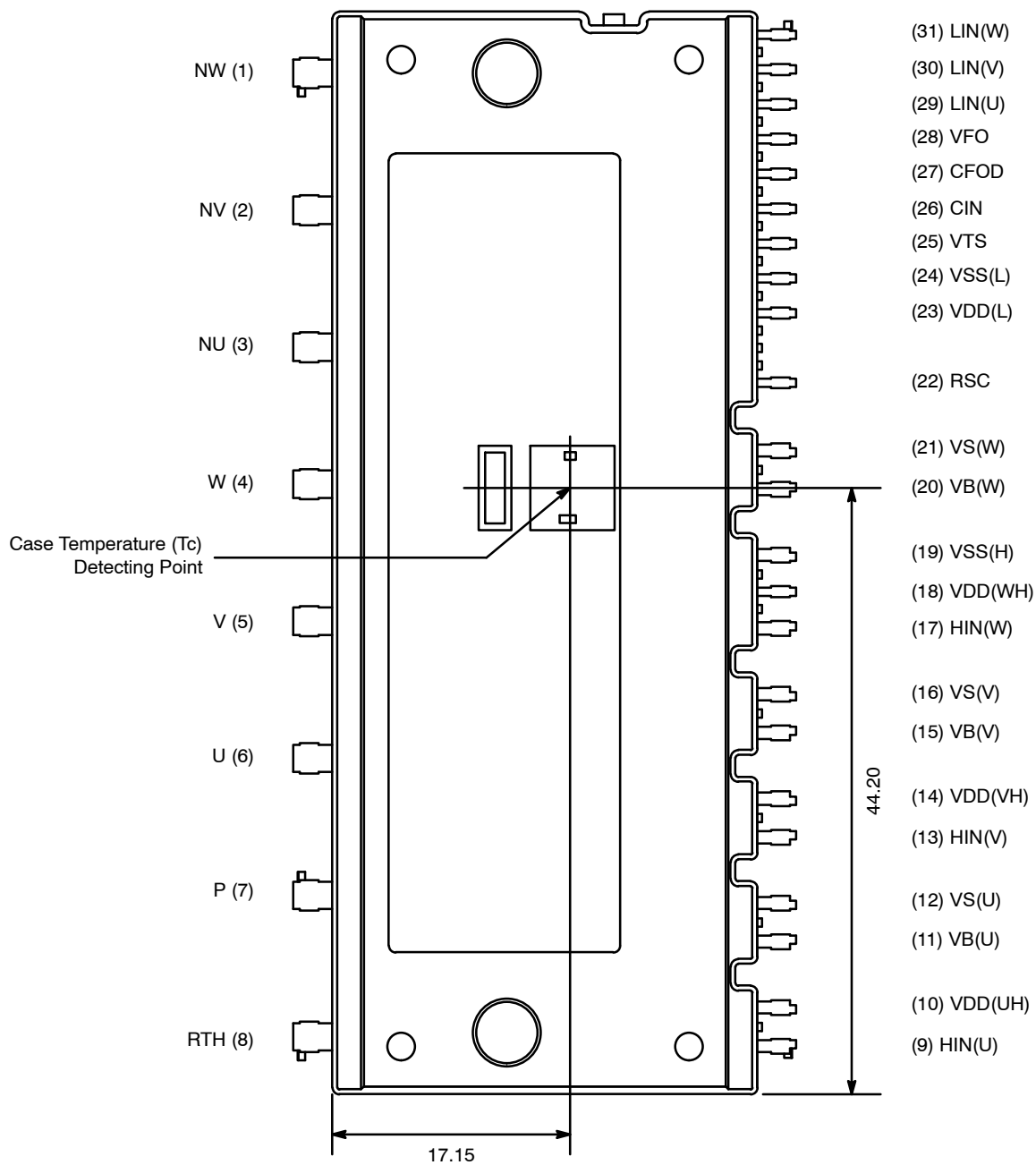

Figure 1. Pin Configuration – Top View

NFAL7565L4BT

PIN DESCRIPTION

Pin Number	Pin Name	Pin Description
1	NW	Negative DC-Link Input for W Phase
2	NV	Negative DC-Link Input for V Phase
3	NU	Negative DC-Link Input for U Phase
4	W	Output for W Phase
5	V	Output for V Phase
6	U	Output for U Phase
7	P	Positive DC-Link Input
8	RTH	Series Resistor for Thermistor (Temperature Detection)
9	HIN(U)	Signal Input for High-Side U Phase
10	VDD(UH)	High-Side Bias Voltage for U Phase IC
11	VB(U)	High-Side Bias Voltage for U Phase IGBT Driving
12	VS(U)	High-Side Bias Voltage GND for U Phase IGBT Driving
13	HIN(V)	Signal Input for High-Side V Phase
14	VDD(VH)	High-Side Bias Voltage for V Phase IC
15	VB(V)	High-Side Bias Voltage for V Phase IGBT Driving
16	VS(V)	High-Side Bias Voltage GND for V Phase IGBT Driving
17	HIN(W)	Signal Input for High-Side W Phase
18	VDD(WH)	High-Side Bias Voltage for W Phase IC
19	VSS(H)	High-Side Common Supply Ground, connected to HVIC
20	VB(W)	High-Side Bias Voltage for W Phase IGBT Driving
21	VS(W)	High-Side Bias Voltage GND for W Phase IGBT Driving
22	RSC	Resistor for Over and Short-Circuit Current Detection
23	VDD(L)	Low-Side Bias Voltage for IC and IGBTs Driving
24	VSS(L)	Low-Side Common Supply Ground, connected to LVIC
25	VTS	Voltage Output for LVIC Temperature Sensing Unit
26	CIN	Input for Current Protection
27	CFOD	Capacitor for Fault Output Duration Selection
28	VFO	Fault Output
29	LIN(U)	Signal Input for Low-Side U Phase
30	LIN(V)	Signal Input for Low-Side V Phase
31	LIN(W)	Signal Input for Low-Side W Phase

NFAL7565L4BT

INTERNAL EQUIVALENT CIRCUIT AND INPUT/OUTPUT PINS

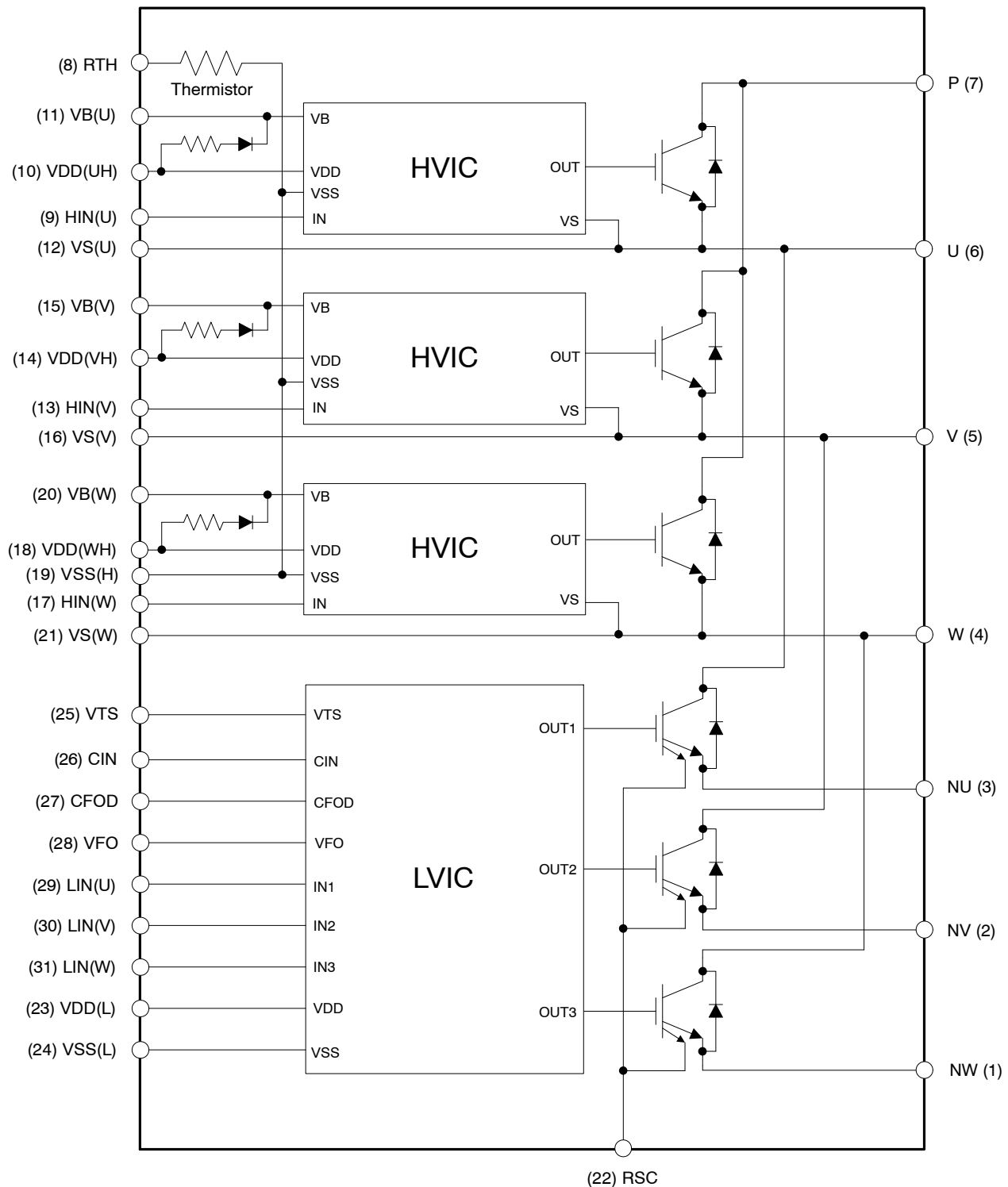

NOTES:

1. Inverter high-side is composed of three normal-IGBTs, freewheeling diodes, and one control IC for each IGBT.
2. Inverter low-side is composed of three sense-IGBTs, freewheeling diodes, and one control IC for each IGBT. It has gate drive and protection functions.
3. Inverter power side is composed of four inverter DC-link input terminals and three inverter output terminals.

Figure 2. Internal Block Diagram

NFAL7565L4BT

ABSOLUTE MAXIMUM RATINGS (T_j = 25°C unless otherwise noted)

Symbol	Rating	Conditions	Rating	Unit
INVERTER PART				
VPN	Supply Voltage	Applied between P – NU, NV, NW	450	V
VPN(surge)	Supply Voltage (Surge)	Applied between P – NU, NV, NW	500	V
Vces	Collector-Emitter Voltage		650	V
±Ic	Each IGBT Collector Current	Tc = 25°C, Tj ≤ 150°C	75	A
±Icp	Each IGBT Collector Current (Peak)	Tc = 25°C, Tj ≤ 150°C, Under 1 ms Pulse Width (Note 4)	150	A
Pc	Collector Dissipation	Tc = 25°C per One Chip (Note 4)	223	W
Tj	Operating Junction Temperature		-40~150	°C

CONTROL PART

VDD	Control Supply Voltage	Applied between VDD(H), VDD(L) – VSS	20	V
VBS	High-Side Control Bias Voltage	Applied between VB(U) – VS(U), VB(V) – VS(V), VB(W) – VS(W)	20	V
VIN	Input Signal Voltage	Applied between HIN(U), HIN(V), HIN(W), LIN(U), LIN(V), LIN(W) – VSS	-0.5~VDD+0.5	V
VFO	Fault Output Supply Voltage	Applied between VFO – VSS	-0.5~VDD+0.5	V
IFO	Fault Output Current	Sink Current at VFO pin	5	mA
VCIN	Current Sensing Input Voltage	Applied between CIN – VSS	-0.5~VDD+0.5	V
Tj	Operating Junction Temperature		-40~150	°C

BOOSTSTRAP DIODE PART

VRRM	Maximum Repetitive Reverse Voltage		650	V
Tj	Operating Junction Temperature		-40~150	°C

TOTAL SYSTEM

VPN(PROT)	Self-Protection Supply Voltage Limit (Short-Circuit Protection Capability)	VDD = VBS = 13.5~16.5 V, Tj = 150°C, Vces < 650 V, Non-Repetitive, < 2 μs	400	V
Tc	Module Case Operation Temperature	See Figure 1	-40~125	°C
Tstg	Storage Temperature		-40~125	°C
Viso	Isolation Voltage	60 Hz, Sinusoidal, AC 1 Minute, Connection Pins to Heat Sink Plate	2500	Vrms

Stresses exceeding those listed in the Maximum Ratings table may damage the device. If any of these limits are exceeded, device functionality should not be assumed, damage may occur and reliability may be affected.

4. These values had been made an acquisition by the calculation considered to design factor.

THERMAL RESISTANCE

Symbol	Parameter	Conditions	Min	Typ	Max	Unit
Rth(j-c)Q	Junction-to-Case Thermal Resistance (Note 5)	Inverter IGBT Part (per 1/6 module)	–	–	0.56	°C/W
Rth(j-c)F		Inverter FWDi Part (per 1/6 module)	–	–	0.84	°C/W

5. For the measurement point of case temperature (Tc), please refer to Figure 1. DBC discoloration and Picker Circle Printing allowed, please refer to application note [AN-9190](#) (Impact of DBC Oxidation on SPM® Module Performance).

NFAL7565L4BT

ELECTRICAL CHARACTERISTICS (T_j = 25°C unless otherwise specified.)

Symbol	Parameter	Conditions	Min	Typ	Max	Unit
--------	-----------	------------	-----	-----	-----	------

INVERTER PART

VCE(sat)	Collector-Emitter Saturation Voltage	VDD = VBS = 15 V IN = 5 V	I _c = 75 A, T _j = 25°C	-	1.55	2.05	V	
VF	FWDi Forward Voltage	IN = 0 V	I _c = -75 A, T _j = 25°C	-	2.05	2.55	V	
HS	ton	Switching Times	VPN = 300 V, VDD = 15 V, I _c = 75 A T _j = 25°C IN = 0 V ↔ 5 V, Inductive Load See Figure 3 (Note 6)	1.40	2.00	2.60	μs	
				tc(on)	-	0.40	0.80	μs
				toff	-	2.10	2.70	μs
				tc(off)	-	0.30	0.60	μs
				trr	-	0.08	-	μs
LS	ton	Switching Times	VPN = 300 V, VDD = 15 V, I _c = 75 A T _j = 25°C IN = 0 V ↔ 5 V, Inductive Load See Figure 3 (Note 6)	1.00	1.60	2.20	μs	
				tc(on)	-	0.30	0.60	μs
				toff	-	2.10	2.70	μs
				tc(off)	-	0.25	0.55	μs
				trr	-	0.08	-	μs
Ices	Collector-Emitter Leakage Current	Vce = Vces	-	-	1	mA		

CONTROL PART

IQDDH	Quiescent VDD Supply Current	VDD(UH,VH,WH) = 15 V, HIN(U,V,W) = 0 V	VDD(UH) - VSS(H), VDD(VH) - VSS(H), VDD(WH) - VSS(H)	-	-	0.30	mA
IQDDL		VDD(L) = 15 V, LIN(U,V,W) = 0 V	VDD(L) - VSS(L)	-	-	3.50	mA
IPDDH	Operating VDD Supply Current	VDD(UH,VH,WH) = 15 V, FPWM = 20 kHz, Duty = 50%, Applied to one PWM Signal Input for High-Side	VDD(UH) - VSS(H), VDD(VH) - VSS(H), VDD(WH) - VSS(H)	-	-	0.40	mA
IPDDL		VDD(L) = 15 V, FPWM = 20 kHz, Duty = 50%, Applied to one PWM Signal Input for Low-Side	VDD(L) - VSS(L)	-	-	7.00	mA
IQBS	Quiescent VBS Supply Current	VDD = VBS = 15 V, HIN(U,V,W) = 0 V	VB(U) - VS(U), VB(V) - VS(V), VB(W) - VS(W)	-	-	0.30	mA
IPBS	Operating VBS Supply Current	VDD = VBS = 15 V, FPWM = 20 kHz, Duty = 50%, Applied to one PWM Signal Input for High-Side	VB(U) - VS(U), VB(V) - VS(V), VB(W) - VS(W)	-	-	6.00	mA
VFOH	Fault Output Voltage	VDD = 15 V, CIN = 0 V, VFO Circuit: 10 kΩ to 5 V Pull-up		4.90	-	-	V
VFOL		VDD = 15 V, CIN = 1 V, IFO = 1 mA		-	-	0.95	V
ISEN	Sensing Current of Each Sense IGBT	VDD = 15 V, LIN = 5 V, Rsc = 0 Ω, No Connection of Shunt Resistor at NU, NV, NW Terminal	I _c = 75 A	-	27.0	-	mA
VSC(ref)	Short Circuit Trip Level	VDD = 15 V	CIN - VSS(L)	0.46	0.48	0.50	V
ISC	Short Circuit Current Level for Trip	Rsc = 15 Ω (±1%), No Connection of Shunt Resistor at NU, NV, NW Terminal (Note 7)		113	-	-	A

NFAL7565L4BT

ELECTRICAL CHARACTERISTICS (T_j = 25°C unless otherwise specified.) (continued)

Symbol	Parameter	Conditions	Min	Typ	Max	Unit	
CONTROL PART							
UVDDD	Supply Circuit Under-Voltage Protection	Detection Level	10.3	–	12.5	V	
UVDDR		Reset Level	10.8	–	13.0	V	
UVBSD		Detection Level	10.0	–	12.0	V	
UVBSR		Reset Level	10.5	–	12.5	V	
VIN(ON)	ON Threshold Voltage	Applied between HIN(U,V,W) – VSS(H), LIN(U,V,W) – VSS(L)	–	–	2.6	V	
VIN(OFF)	OFF Threshold Voltage		0.8	–	–	V	
VTS	Voltage Output for LVIC Temperature Sensing Unit	VDD(L) = 15 V, TLVIC = 25°C See Figure 6 and 7 (Note 8)	0.909	1.030	1.151	V	
tFOD	Fault-Out Pulse Width	CFOD = 22 nF (Note 9)	1.6	–	–	ms	
RTH	Resistance of Thermistor	At TTH = 25°C	See Figure 8 (Note 10)	–	47	–	kΩ
		At TTH = 100°C		–	2.9	–	kΩ

BOOTSTRAP DIODE/RESISTOR PART

VF	Forward Voltage	I _f = 0.1 A, T _j = 25°C	See Figure 9	2.1	2.5	2.9	V
RBOOT	Bootstrap Resistor			12.5	15.5	18.5	Ω

Product parametric performance is indicated in the Electrical Characteristics for the listed test conditions, unless otherwise noted. Product performance may not be indicated by the Electrical Characteristics if operated under different conditions.

- ton and toff include the propagation delay of the internal drive IC. tc(on) and tc(off) are the switching times of IGBT under the given gate-driving condition internally. For the detailed information, please see Figure 3.
- Short-circuit current protection functions only at the low-sides because the sense current is divided from main current at low-side IGBTs. Inserting the shunt resistor for monitoring the phase current at NU, NV, NW terminal, the trip level of the short-circuit current is changed.
- TLVIC is the temperature of LVIC itself. VTS is only for sensing temperature of LVIC and cannot shutdown IGBTs automatically. The relationship between VTS voltage output and LVIC temperature is described in Figure 6. It is recommended to add a ceramic capacitor of 10 nF or more between VTS and VSS (Signal Ground) to make the VTS more stable as described in Figure 7. Refer to the application note for this products about usage of VTS.
- The fault-out pulse width tFOD depends on the capacitance value of CFOD according to the following approximate equation:
 $tFOD = 0.1 \times 10^6 \times CFOD [s]$
- TTH is the temperature of thermistor itself. To know case temperature (Tc), conduct experiments considering the application.

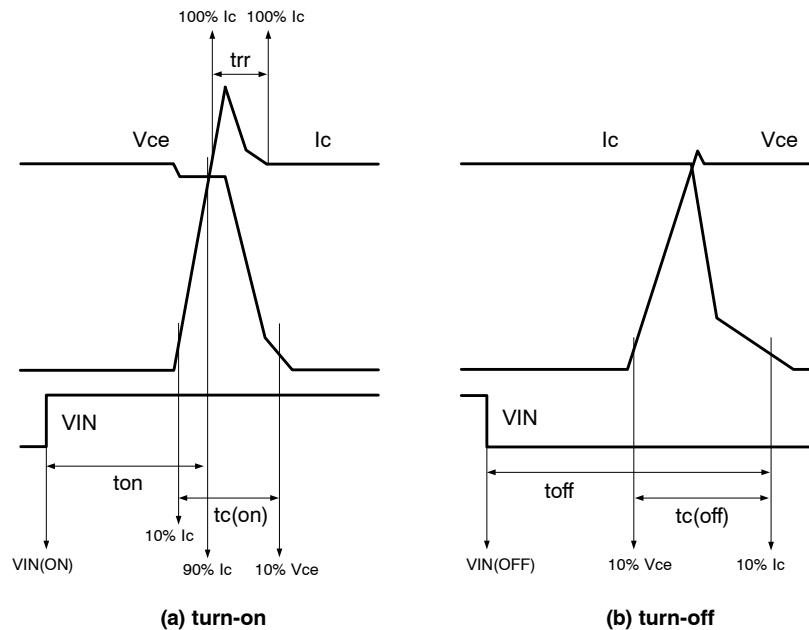

Figure 3. Switching Time Definition

NFAL7565L4BT

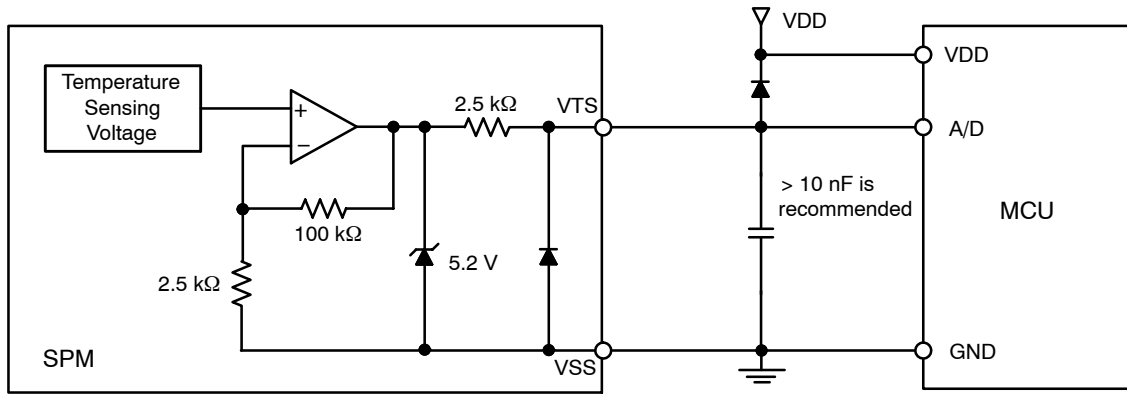

Figure 7. Internal Block Diagram and Interface Circuit of VTS

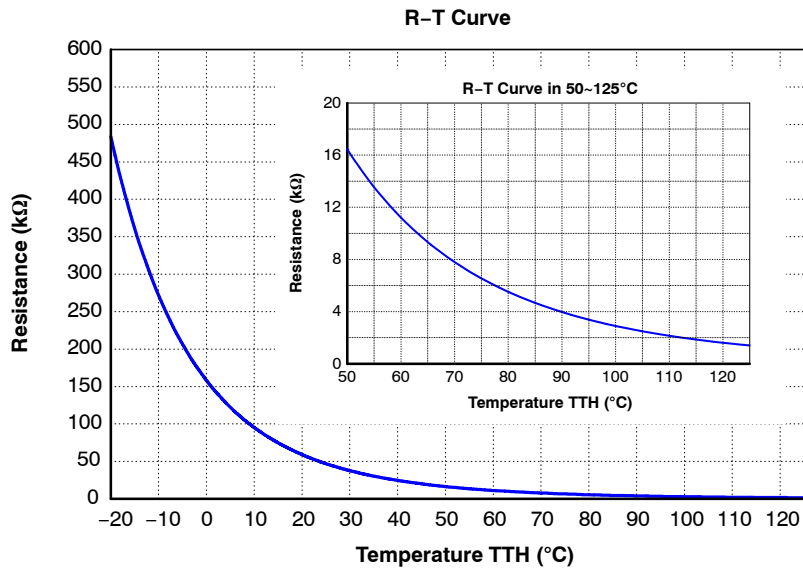

Figure 8. R-T Curve of Built-in Thermistor

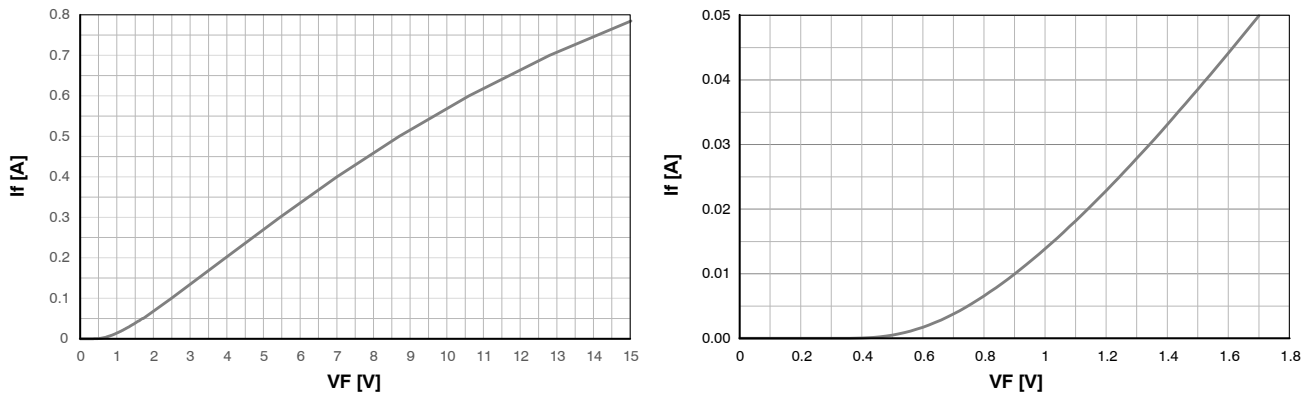

Figure 9. Characteristics of Bootstrap Diode/Resistor (Right Figure is Enlarged Figure)

NFAL7565L4BT

RECOMMENDED OPERATING RANGES

Symbol	Parameter	Conditions	Min	Typ	Max	Unit	
VPN	Supply Voltage	Applied between P-NU, NV, NW	-	300	400	V	
VDD	Control Supply Voltage	Applied between VDD(UH,VH,WH)-VSS(H), VDD(L)-VSS(L)	13.5	15.0	16.5	V	
VBS	High-Side Control Bias Voltage	Applied between VB(U)-VS(U), VB(V)-VS(V), VB(W)-VS(W)	13.0	15.0	18.5	V	
dVDD/dt, dVBS/dt	Control Supply Variation		-1	-	+1	V/ μ s	
tdead	Blanking Time for Preventing Arm - Short	For Each Input Signal	2.5	-	-	μ s	
FPWM	PWM Input Signal	$-40^{\circ}\text{C} \leq T_c \leq 125^{\circ}\text{C}$, $-40^{\circ}\text{C} \leq T_j \leq 150^{\circ}\text{C}$	-	-	20	kHz	
Io	Allowable r.m.s. Output Current	VPN = 300 V, VDD = VBS = 15 V, P.F = 0.8, Sinusoidal PWM $T_c \leq 125^{\circ}\text{C}$, $T_j \leq 150^{\circ}\text{C}$ (Note 11)	FPWM = 5 kHz	-	-	38	Arms
			FPWM = 15 kHz	-	-	26	
VSEN	Voltage for Current Sensing	Applied between NU, NV, NW-VSS (Including Surge Voltage)	-5.0	-	+5.0	V	
PWIN(ON)	Minimum Input Pulse Width	(Note 12)	1.3	-	-	μ s	
PWIN(OFF)		VDD = VBS = 15 V, $I_C \leq 150$ A, Wiring Inductance between NU, NV, NW and DC Link N < 10 nH (Note 12)	2.0	-	-		
Tj	Junction Temperature		-40	-	+150	$^{\circ}\text{C}$	

Functional operation above the stresses listed in the Recommended Operating Ranges is not implied. Extended exposure to stresses beyond the Recommended Operating Ranges limits may affect device reliability.

11. This allowable output current value is the reference data for the safe operation of this product. This may be different from the actual application and operating condition.

12. This product might not make output response if input pulse width is less than the recommended value.

PACKAGE MARKING AND ORDERING INFORMATION

Device	Device Marking	Package	Shipping
NFAL7565L4BT	NFAL7565L4BT	SPM49-CAB	6 Units/Tube

NFAL7565L4BT

MECHANICAL CHARACTERISTICS AND RATINGS

Parameter	Conditions	Min	Typ	Max	Unit	
Device Flatness	See Figure 10	-50	-	100	μm	
Mounting Torque	Mounting Screw: M4 See Figure 11	Recommended 1.18 N · m	0.98	1.18	1.47	N · m
		Recommended 12.03 kg · cm	10.00	12.03	14.98	kg · cm
Terminal Pulling Strength	Load 19.6 N	10	-	-	s	
Terminal Bending Strength	Load 9.8 N, 90 degrees Bend	2	-	-	times	
Weight		-	44.5	-	g	

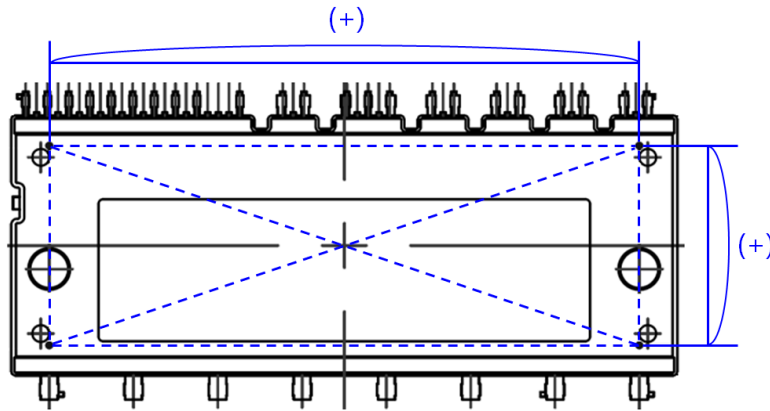
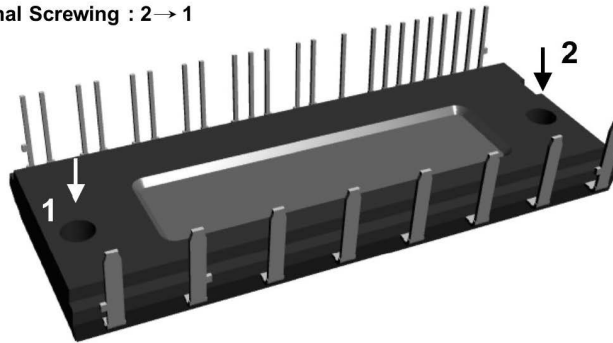

Figure 10. Flatness Measurement Position

Pre - Screwing : 1 → 2
Final Screwing : 2 → 1



NOTES:

13. Do not over torque when mounting screws. Too much mounting torque may cause DBC cracks, as well as bolts and Al heat-sink destruction.
14. Avoid one-sided tightening stress. Figure 11 shows the recommended torque order for the mounting screws. Uneven mounting can cause the DBC substrate of package to be damaged. The pre-screwing torque is set to 20~30% of maximum torque rating.

Figure 11. Mounting Screws Torque Order

NFAL7565L4BT

TIME CHARTS OF SPMs PROTECTIVE FUNCTION

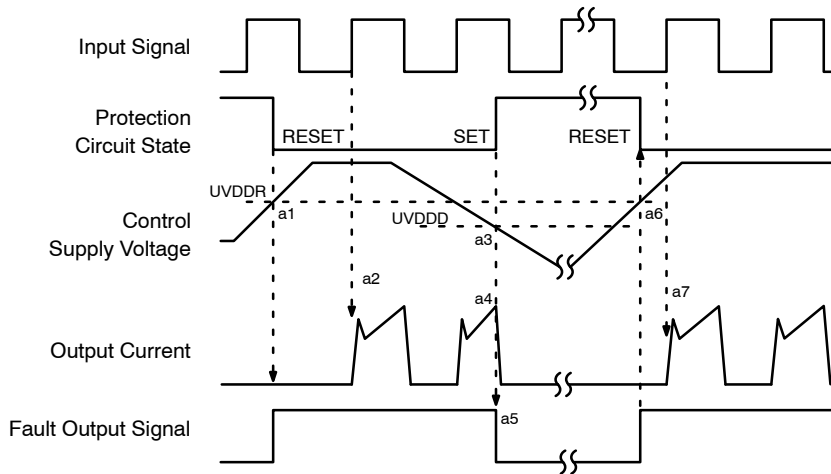

- a1: Control supply voltage rises: after the voltage rises UVDDR, the circuits start to operate when the next input is applied.
- a2: Normal operation: IGBT ON and carrying current.
- a3: Under-voltage detection (UVDDD).
- a4: IGBT OFF in spite of control input condition.
- a5: Fault output operation starts with a fixed pulse width according to the condition of the external capacitor CFOD.
- a6: Under-voltage reset (UVDDR).
- a7: Normal operation: IGBT ON and carrying current by triggering next signal from LOW to HIGH.

Figure 12. Under-voltage Protection (Low-side)

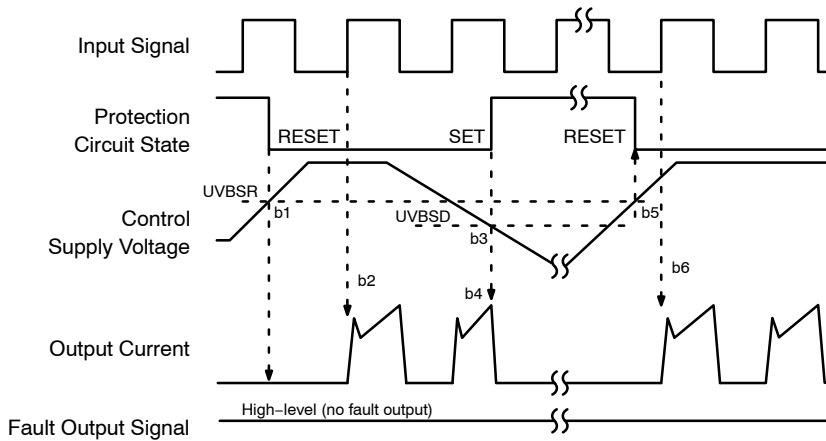

- b1: Control supply voltage rises: after the voltage reaches UVBSR, the circuits start to operate when the next input is applied.
- b2: Normal operation: IGBT ON and carrying current.
- b3: Under-voltage detection (UVBSD).
- b4: IGBT OFF in spite of control input condition, but there is no fault output signal.
- b5: Under-voltage reset (UVBSR).
- b6: Normal operation: IGBT ON and carrying current by triggering next signal from LOW to HIGH.

Figure 13. Under-voltage Protection (High-side)

NFAL7565L4BT

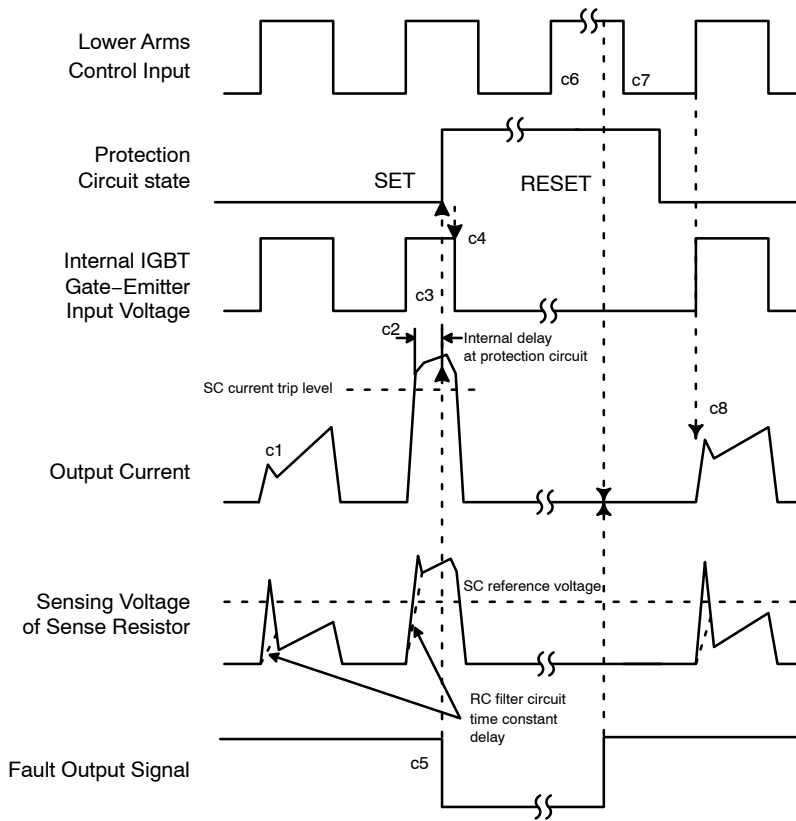

(With the external sense resistance and RC filter connection)

c1: Normal operation: IGBT ON and carrying current.

c2: Short-circuit current detection (SC trigger).

c3: All low-side IGBTs gate are hard interrupted.

c4: All low-side IGBTs turn OFF.

c5: Fault output operation starts with a fixed pulse width according to the condition of the external capacitor CFOD.

c6: Input HIGH – IGBT ON state, but during the active period of fault output, the IGBT doesn't turn ON.

c7: Fault output operation finishes, but IGBT doesn't turn on until triggering the next signal from LOW to HIGH.

c8: Normal operation: IGBT ON and carrying current.

Figure 14. Short-circuit Current Protection (Low-side Operation Only)

INPUT/OUTPUT INTERFACE CIRCUIT

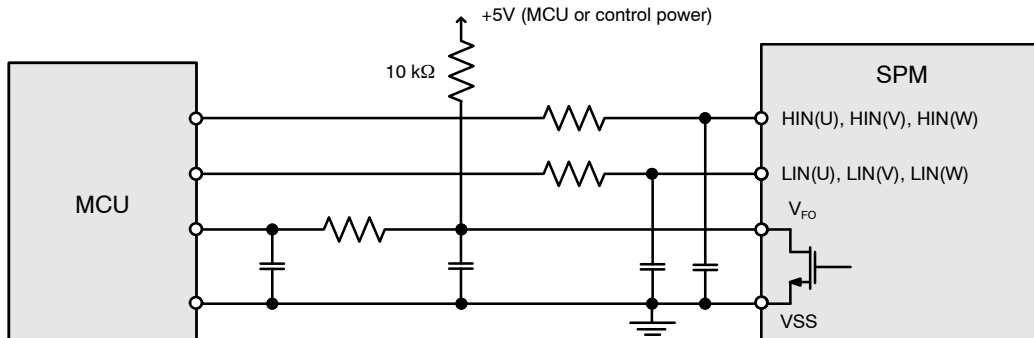

NOTE:

15. RC coupling at each input might change depending on the PWM control scheme used in the application and the wiring impedance of the application's printed circuit board. The input signal section of the SPM49 product integrates 5 kΩ (typ.) pull-down resistor. Therefore, when using an external filtering resistor, please pay attention to the signal voltage drop at input terminal.

Figure 15. Recommended MCU I/O Interface Circuit

NFAL7565L4BT

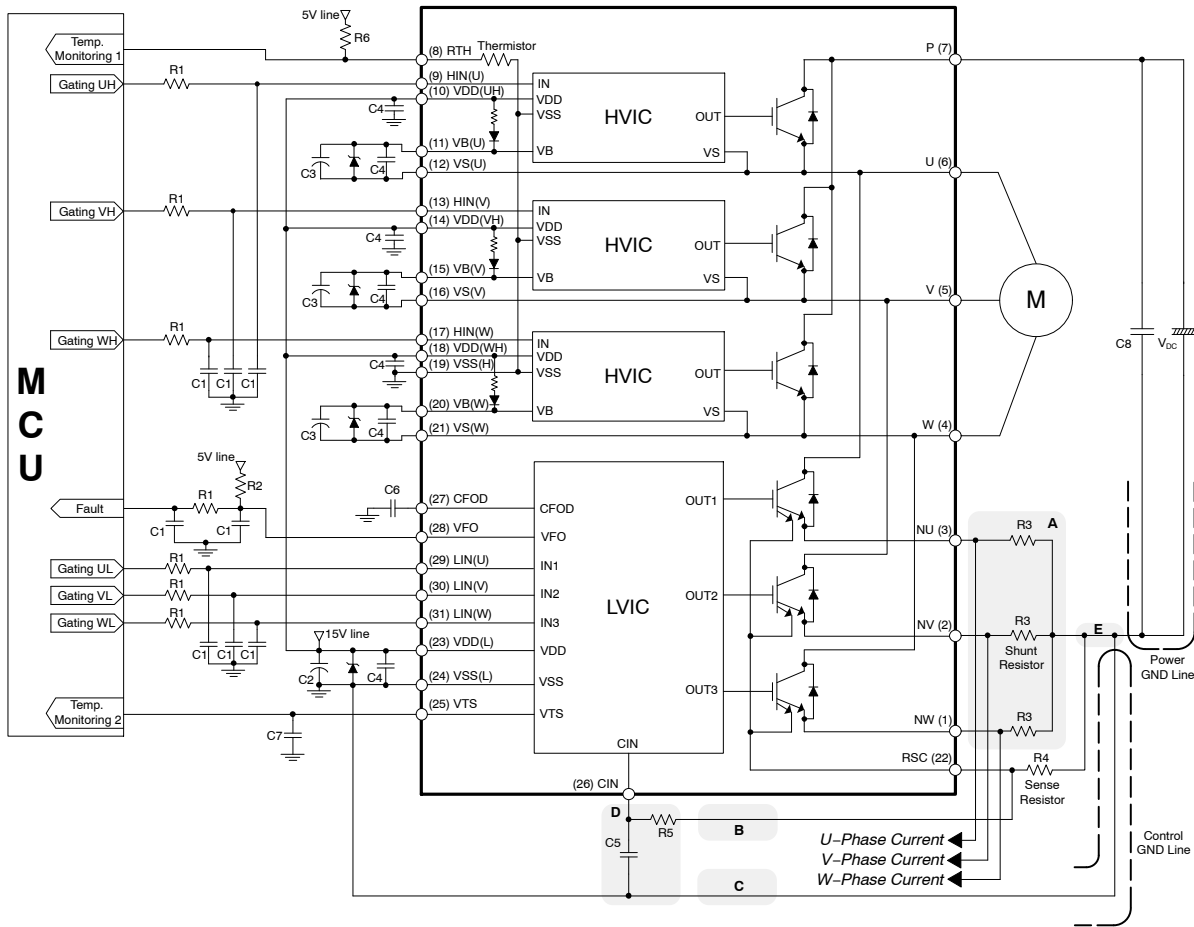

NOTES:

16. To avoid malfunction, the wiring of each input should be as short as possible (less than 2-3 cm).
17. VFO output is an open-drain type. This signal line should be pulled up to the positive side of the MCU or control power supply with a resistor that makes IFO up to 1 mA. Please refer to Figure 15.
18. Fault out pulse width can be adjusted by capacitor C6 connected to the CFOD terminal.
19. Input signal is active-HIGH type. There is a 5 kΩ resistor inside the IC to pull-down each input signal line to GND. RC coupling circuits should be adopted for the prevention of input signal oscillation. R1C1 time constant should be selected in the range 50~150 ns (recommended R1 = 100 Ω, C1 = 1 nF).
20. Each wiring pattern inductance of point A should be minimized (recommend less than 10 nH). Use the shunt resistor R3 of surface mounted (SMD) type to reduce wiring inductance. To prevent malfunction, wiring of point E should be connected to the terminal of the shunt resistor R3 as close as possible.
21. To insert the shunt resistor to measure each phase current at NU, NV, NW terminal, it makes to change the trip level ISC about the short-circuit current.
22. To prevent errors of the protection function, the wiring of points B, C, and D should be as short as possible. The wiring of B between CIN filter and RSC terminal should be divided at the point that is close to the terminal of sense resistor R4.
23. For stable protection function, use the sense resistor R4 with resistance variation within 1% and low inductance value.
24. In the short-circuit protection circuit, select the R5C5 time constant in the range 2.0~2.5 μs. R5 should be selected with a minimum of 10 times larger resistance than sense resistor R4. Do enough evaluation on the real system because short-circuit protection time may vary wiring pattern layout and value of the R5C5 time constant.
25. Each capacitor should be mounted as close to the pins of the SPM product as possible.
26. To prevent surge destruction, the wiring between the smoothing capacitor C8 and the P & GND pins should be as short as possible. The use of a high-frequency non-inductive capacitor of around 0.1~0.22 μF between the P & GND pins is recommended.
27. Relays are used in most systems of electrical equipment in industrial application. In these cases, there should be sufficient distance between the MCU and the relays.
28. The Zener diode or transient voltage suppressor should be adopted for the protection of ICs from the surge destruction between each pair of control supply terminals (recommended Zener diode is 22 V/1 W, which has the lower Zener impedance characteristic than about 15 Ω).
29. C2 of around seven times larger than bootstrap capacitor C3 is recommended.
30. Please choose the electrolytic capacitor with good temperature characteristic in C3. Choose 0.1~0.2 μF R-category ceramic capacitors with good temperature and frequency characteristics in C4.

Figure 16. Typical Application Circuit

SPM is registered trademarks of Semiconductor Components Industries, LLC (SCILLC) or its subsidiaries in the United States and/or other countries.

MECHANICAL CASE OUTLINE PACKAGE DIMENSIONS

ON Semiconductor®

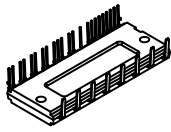

DIP31, 79x30/SPM49 CAB CASE MODGQ ISSUE O

DATE 06 DEC 2018

NOTES:

1. DIMENSIONING AND TOLERANCING PER ASME Y14.5M, 2009.
2. CONTROLLING DIMENSION: MILLIMETERS
3. DIMENSION b and c APPLY TO THE PLATED LEADS AND ARE MEASURED BETWEEN 1.00 AND 2.00 FROM THE LEAD TIP.
4. POSITION OF THE LEAD IS DETERMINED AT THE BASE OF THE LEAD WHERE IT EXITS THE PACKAGE BODY.

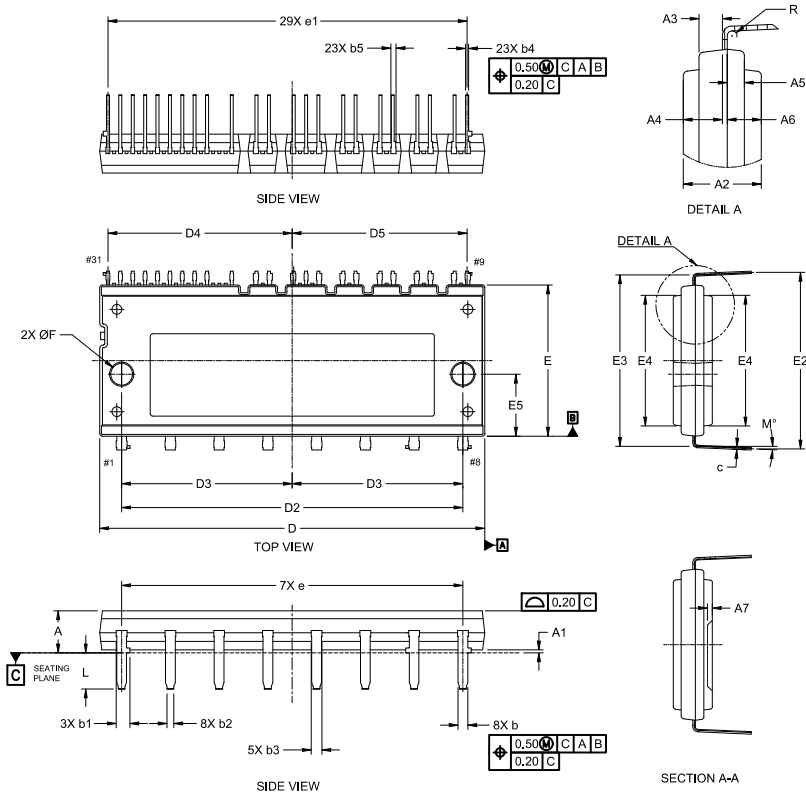

DIM	MILLIMETERS		
	MIN.	NOM.	MAX.
A	8.40	8.60	8.80
A1	0.40	0.60	0.80
A2	7.90	8.00	8.10
A3	2.30	2.40	2.50
A4	3.90	4.00	4.10
A5	1.65	1.75	1.85
A6	3.40	3.50	3.60
A7	1.00 REF		
b	1.90	2.00	2.10
b1	—	—	2.80
b2	1.40 REF		
b3	—	—	2.20
b4	0.50	0.60	0.70
b5	—	—	0.80
c	0.45	0.50	0.60
D	78.80	79.00	79.20
D1	49.50	49.70	49.90
D2	69.85	70.00	70.15
D3	34.80	35.00	35.20
D4	37.60	37.80	38.00
D5	35.66	35.86	36.06

DIM	MILLIMETERS		
	MIN.	NOM.	MAX.
E	30.80	31.00	31.20
E1	12.30	12.50	12.70
E2	35.75	36.20	36.65
E3	35.17 REF		
E4	26.60	26.80	27.00
E5	12.55	12.70	12.85
E6	6.80	7.00	7.20
e	10.00 BSC		
e1	2.54 BSC		
F	4.40	4.50	4.60
L	7.40 REF		
M	—	—	5.0°
R	0.50 REF		

GENERIC MARKING DIAGRAM*

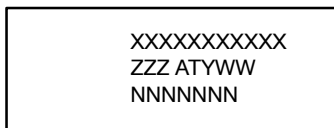

XXXX = Specific Device Code
 ZZZ = Assembly Lot Code
 AT = Assembly & Test Location
 Y = Year
 W = Work Week
 NNN = Serial Number

*This information is generic. Please refer to device data sheet for actual part marking. Pb-Free indicator, "G" or microdot "▪", may or may not be present. Some products may not follow the Generic Marking.

DOCUMENT NUMBER:	98AON98538G	Electronic versions are uncontrolled except when accessed directly from the Document Repository. Printed versions are uncontrolled except when stamped "CONTROLLED COPY" in red.
DESCRIPTION:	DIP31, 79x30/SPM49 CAB	PAGE 1 OF 1

ON Semiconductor and ON are trademarks of Semiconductor Components Industries, LLC dba ON Semiconductor or its subsidiaries in the United States and/or other countries. ON Semiconductor reserves the right to make changes without further notice to any products herein. ON Semiconductor makes no warranty, representation or guarantee regarding the suitability of its products for any particular purpose, nor does ON Semiconductor assume any liability arising out of the application or use of any product or circuit, and specifically disclaims any and all liability, including without limitation special, consequential or incidental damages. ON Semiconductor does not convey any license under its patent rights nor the rights of others.

ON Semiconductor and  are trademarks of Semiconductor Components Industries, LLC dba ON Semiconductor or its subsidiaries in the United States and/or other countries. ON Semiconductor owns the rights to a number of patents, trademarks, copyrights, trade secrets, and other intellectual property. A listing of ON Semiconductor's product/patent coverage may be accessed at www.onsemi.com/site/pdf/Patent-Marking.pdf. ON Semiconductor reserves the right to make changes without further notice to any products herein. ON Semiconductor makes no warranty, representation or guarantee regarding the suitability of its products for any particular purpose, nor does ON Semiconductor assume any liability arising out of the application or use of any product or circuit, and specifically disclaims any and all liability, including without limitation special, consequential or incidental damages. Buyer is responsible for its products and applications using ON Semiconductor products, including compliance with all laws, regulations and safety requirements or standards, regardless of any support or applications information provided by ON Semiconductor. "Typical" parameters which may be provided in ON Semiconductor data sheets and/or specifications can and do vary in different applications and actual performance may vary over time. All operating parameters, including "Typicals" must be validated for each customer application by customer's technical experts. ON Semiconductor does not convey any license under its patent rights nor the rights of others. ON Semiconductor products are not designed, intended, or authorized for use as a critical component in life support systems or any FDA Class 3 medical devices or medical devices with a same or similar classification in a foreign jurisdiction or any devices intended for implantation in the human body. Should Buyer purchase or use ON Semiconductor products for any such unintended or unauthorized application, Buyer shall indemnify and hold ON Semiconductor and its officers, employees, subsidiaries, affiliates, and distributors harmless against all claims, costs, damages, and expenses, and reasonable attorney fees arising out of, directly or indirectly, any claim of personal injury or death associated with such unintended or unauthorized use, even if such claim alleges that ON Semiconductor was negligent regarding the design or manufacture of the part. ON Semiconductor is an Equal Opportunity/Affirmative Action Employer. This literature is subject to all applicable copyright laws and is not for resale in any manner.

PUBLICATION ORDERING INFORMATION

LITERATURE FULFILLMENT:

Literature Distribution Center for ON Semiconductor
19521 E. 32nd Pkwy, Aurora, Colorado 80011 USA
Phone: 303-675-2175 or 800-344-3860 Toll Free USA/Canada
Fax: 303-675-2176 or 800-344-3867 Toll Free USA/Canada
Email: orderlit@onsemi.com

N. American Technical Support: 800-282-9855 Toll Free
USA/Canada
Europe, Middle East and Africa Technical Support:
Phone: 421 33 790 2910

ON Semiconductor Website: www.onsemi.com

Order Literature: <http://www.onsemi.com/orderlit>

For additional information, please contact your local
Sales Representative