

# Cree® LMD300, LMD400 & LMD600 LED Module Drivers



## PRODUCT DESCRIPTION

Cree LED modules provide lighting designers and manufacturers with simple, easy-to-adopt LED lighting solutions that reduce luminaire development time and speed time-to-market. Cree LMD300, LMD400 and LMD600 LED module drivers are specifically designed to work with the Cree LMH2 2000-, 3000-, 4000- and 6000-lumen light sources to jump-start the design process for recessed downlights, wall sconces or pendant lights in demanding end markets such as retail, museums, hospitality and restaurants.

## FEATURES

- Input voltage options: 100-240 V, 100-277 V, 120-277 V & 220-240 V
- 0/1-10 V dimming support for 100-240 V, 100-277 V, 120-277 V & 220-240 V options
- DALI + Touch dimming support for 220-240 V option
- Optimized for Cree LMH2 2000-, 3000- 4000- and 6000-lm light sources
- LMD400 enables California Title 24 compliance

## TABLE OF CONTENTS

Order Codes.....	2
Characteristics - LMD300 100- to 240-V 0/1-10 V Dimming Driver .....	2
Characteristics - LMD300 120- to 277-V 0/1-10 V Dimming Driver .....	3
Characteristics - LMD300 220- to 240-V 0/1-10 V Dimming Driver .....	3
Characteristics - LMD300 220- to 240-V DALI + Touch Dimming Driver .....	4
Characteristics - LMD400 120- to 277-V 0/1-10 V Dimming Driver .....	4
Characteristics - LMD600 100- to 277-V 0/1-10 V Dimming Driver .....	5
Dimming .....	6
Mechanical Dimensions .....	7
Wiring Diagrams.....	10
Thermal Design.....	13
Emergency Battery Operation .....	13
Safety and Regulatory Notes.....	14
Packaging.....	16



## ORDER CODES

### LMD300

Nominal Input Voltage (VAC)	Frequency (Hz)	Typical Output Current (mA)	Dimming	Order Code
100-240	50/60	900	0/1-10 V	LMD300-0040-C900-8030000
120-277	50/60	900	0/1-10 V	LMD300-0040-C900-7030000
220-240	50/60	900	0/1-10 V	LMD300-0040-C900-2030000
220-240	50/60	900	DALI + Touch	LMD300-0040-C900-2020000

### LMD400

Nominal Input Voltage (VAC)	Frequency (Hz)	Typical Output Current (mA)	Dimming	Order Code
120-277	50/60	940	0/1-10 V	LMD400-0048-C940-7030000

### LMD600

Nominal Input Voltage (VAC)	Frequency (Hz)	Typical Output Current (mA)	Dimming	Order Code
100-277	50/60	1700	0/1-10 V	LMD600-0100-C1A7-7030000

## CHARACTERISTICS - LMD300 100- TO 240-V 0/1-10 V DIMMING DRIVER

Order Code: LMD300-0040-C900-8030000

Characteristics	Unit	Minimum	Typical	Maximum
Input voltage range	VAC	90		264
Input power	W			40
Output current	mA		900	
Output voltage	V			40
Driver efficiency (@ 55 °C) - with LMH2 2000-lm light source	%		85	
Driver efficiency (@ 55 °C) - with LMH2 3000-lm light source	%		86	
Power factor - with LMH2 2000-lm light source			0.95	
Power factor - with LMH2 3000-lm light source			0.95	
LED driver case temperature	°C	0		70

- 3-D models (.STEP files) for the LMD300 LED module drivers are available on the Cree website by selecting the Documentation tab on the [LMH2 product page](#).

### CHARACTERISTICS - LMD300 120- TO 277-V 0/1-10 V DIMMING DRIVER

Order Code: LMD300-0040-C900-7030000

Characteristics	Unit	Minimum	Typical	Maximum
Input voltage range	VAC	108		305
Input power	W			40
Output current	mA		900	
Output voltage	V			40
Driver efficiency (@ 55 °C) - with LMH2 2000-lm light source	%		85	
Driver efficiency (@ 55 °C) - with LMH2 3000-lm light source	%		86	
Power factor - with LMH2 2000-lm light source			0.95	
Power factor - with LMH2 3000-lm light source			0.95	
Dimming current @ 120 V	mA			2.3
Dimming current @ 277 V	mA			2.3
LED driver case temperature	°C	0		70

- 3-D models (.STEP files) for the LMD300 LED module drivers are available on the Cree website by selecting the Documentation tab on the [LMH2 product page](#).

### CHARACTERISTICS - LMD300 220- TO 240-V 0/1-10 V DIMMING DRIVER

Order Code: LMD300-0040-C900-2030000

Characteristics	Unit	Minimum	Typical	Maximum
Input voltage range	VAC	207	230	264
Input power	W			40
Output current	mA		900	
Output voltage	V			39
Driver efficiency (@ 55 °C) - with LMH2 2000-lm light source	%		85	
Driver efficiency (@ 55 °C) - with LMH2 3000-lm light source	%		86	
Power factor - with LMH2 2000-lm light source			0.95	
Power factor - with LMH2 3000-lm light source			0.95	
LED driver case temperature	°C	0		70

- 3-D models (.STEP files) for the LMD300 LED module drivers are available on the Cree website by selecting the Documentation tab on the [LMH2 product page](#).

### CHARACTERISTICS - LMD300 220- TO 240-V DALI + TOUCH DIMMING DRIVER

Order Code: LMD300-0040-C900-2020000

Characteristics	Unit	Minimum	Typical	Maximum
Input voltage range	VAC	207	230	264
Input power	W			40
Output current	mA		900	
Output voltage	V			39
Driver efficiency (@ 55 °C) - with LMH2 2000-lm light source	%		81	
Driver efficiency (@ 55 °C) - with LMH2 3000-lm light source	%		85	
Power factor - with LMH2 2000-lm light source			0.95	
Power factor - with LMH2 3000-lm light source			0.95	
LED driver case temperature	°C	0		70

- 3-D models (.STEP files) for the LMD300 LED module drivers are available on the Cree website by selecting the Documentation tab on the [LMH2 product page](#).

### CHARACTERISTICS - LMD400 120- TO 277-V 0/1-10 V DIMMING DRIVER

Order Code: LMD400-0048-C940-7030000

Characteristics	Unit	Minimum	Typical	Maximum
Input voltage range	VAC	108		305
Input power	W			48
Output current	mA		940	
Output voltage	V			22-44
Driver efficiency (@ 55 °C) - with LMH2 2000-lm light source	%		85	
Driver efficiency (@ 55 °C) - with LMH2 3000-lm light source	%		86	
Driver efficiency (@ 55 °C) - with LMH2 4000-lm light source	%		87	
Power factor - with LMH2 2000-lm light source			0.95	
Power factor - with LMH2 3000-lm light source			0.95	
Power factor - with LMH2 4000-lm light source			0.95	
Dimming current @ 120 V	mA			2.3
Dimming current @ 277 V	mA			2.3
LED driver case temperature	°C	0		90

- 3-D models (.STEP files) for the LMD400 LED module driver are available on the Cree website by selecting the Documentation tab on the [LMH2 product page](#).

**CHARACTERISTICS - LMD600 100- TO 277-V 0/1-10 V DIMMING DRIVER**

Order Code: LMD600-0100-C1A7-7030000

Characteristics	Unit	Minimum	Typical	Maximum
Input voltage range	VAC	90		305
Input power	W			102
Output current	mA		1700	
Output voltage	V			25-52
Driver efficiency (@ 55 °C) - with LMH2 6000-lm light source	%		87	
Power factor - with LMH2 6000-lm light source			0.95	
Dimming current @ 120 V	mA			.05
Dimming current @ 277 V	mA			.05
LED driver case temperature	°C	0		76

- 3-D models (.STEP files) for the LMD600 LED module driver are available on the Cree website by selecting the Documentation tab on the [LMH2 product page](#).

## DIMMING

The LMH2 2000-, 3000- and 4000-lm light sources can use the LMD300 LED module driver with either DALI + Touch dimming or 0/1-10 V dimming and use the LMD400 LED module driver with 0/1-10 V dimming. The LMH2 6000-lm light source can use the LMD600 LED module driver with 0/1-10 V dimming.

Driver	Input Voltage	Dimming	Lowest Light Level
LMD300-0040-C900-8030000	100-240 V	0/1-10 V	10%
LMD300-0040-C900-7030000	120-277 V	0/1-10 V	10%
LMD300-0040-C900-2030000	220-240 V	0/1-10 V	10%
LMD300-0040-C900-2020000	220-240 V	DALI + Touch	10%
LMD400-0048-C940-7030000	120-277 V	0/1-10 V	10%
LMD600-0100-C1A7-7030000	100-277 V	0/1-10 V	1%

The LMH2 2000, 3000- and 4000-lm light sources combined with the LMD300 DALI + Touch driver is a DALI-certified device for use with DALI-compliant dimmers.

**Caution** - DALI dimming and Touch dimming should not be used on the same luminaire.

### Setting Up the LMD300 DALI + Touch Driver in Touch Control Mode

The LMD300 DALI + Touch driver can be used in touch control mode in installations where DALI control is not installed. To set up touch control mode, wire the driver DALI terminals to 220- to 240-VAC mains power through a pushbutton (a momentary switch rated for 220 to 240 VAC and 0.5 A) as shown in the Wiring Diagrams section of this data sheet. Multiple LMH2 modules can be connected together to be controlled by the same pushbutton.

To activate touch control mode, turn on power to the LMH2 LED module without pressing the pushbutton, i.e., the switch is open. After one (1) second, the driver automatically enters touch control mode and the pushbutton can then be used to control the LMH2.

### Touch Control Mode Operation

In touch control mode, a single pushbutton turns the LMH2 LED module on and off and changes its brightness. To turn the module on or off, press and release the pushbutton quickly (in less than 300 ms). When the module is on, change its brightness by pressing and holding the pushbutton. The brightness alternately increases or decreases each time the pushbutton is pressed and held. When the desired brightness is reached, release the pushbutton. The module will remain at this brightness level until the pushbutton is pressed and held again, even if it is turned off and back on.

Two methods can be used to quickly reach maximum and minimum brightness. For maximum brightness instantly, double-click the pushbutton when the LMH2 LED module is on. Double-clicking means quickly pressing and releasing the pushbutton twice in succession (with less than 300 ms between presses). For minimum brightness, press and hold the pushbutton when the LMH2 is off. The LMH2 LED module turns on at minimum brightness and increases in brightness until the pushbutton is released.

If multiple LMH2 LED modules are controlled by the same pushbutton, the modules can lose synchronization and not all perform the same action in response to the pushbutton. To synchronize all the modules connected to one pushbutton, press and hold the pushbutton

for at least one (1) second and release it, then double-click the pushbutton. All connected modules will then be on at maximum brightness, regardless of their previous states.

Touch control mode operation is summarized in the following table.

Pushbutton Operation	Module Operation in Touch Mode	
	Module On	Module Off
Click	All off	All on at previous brightness
Press and hold	Brightness increases or decreases opposite of previous press and hold	All on at minimum brightness, increasing brightness while pushbutton held
Double-click	All on at maximum brightness	

**MECHANICAL DIMENSIONS**

**Physical Characteristics of the LMD300, LMD400 & LMD600 Drivers**

Physical Characteristic	LMD300 100- to 240-V Driver	LMD300 120- to 277-V Driver	LMD300 220- to 240-V Drivers	LMD400 120- to 277-V Driver	LMD600 100- to 277-V Driver
Weight (g)	195	195	264	280	440
Maximum height (mm)	37.5	37.5	35	37.5	47
Maximum length (mm)	90	90	205	90	160
Maximum width (mm)	90	90	80	90	63

**LMD300 100- to 240-V and LMD300 & LMD400 120- to 277-V Drivers<sup>1</sup>**

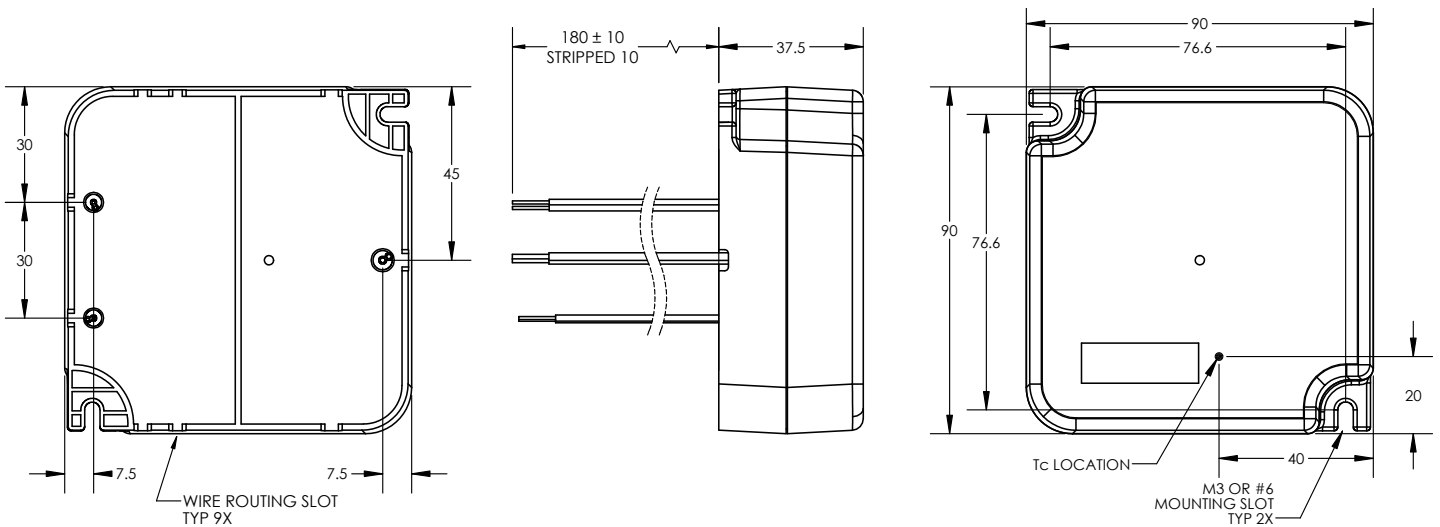

<sup>1</sup> Dimensions for all the diagrams are in mm and are for reference only. For exact dimensions and tolerances, refer to the 3-D models (.STEP files) for the LMD300, LMD400 and LMD600 drivers available by selecting the Documentation tab on the [LMH2 product page](#).

**LMD300 220- to 240-V Driver - With Standard Covers**

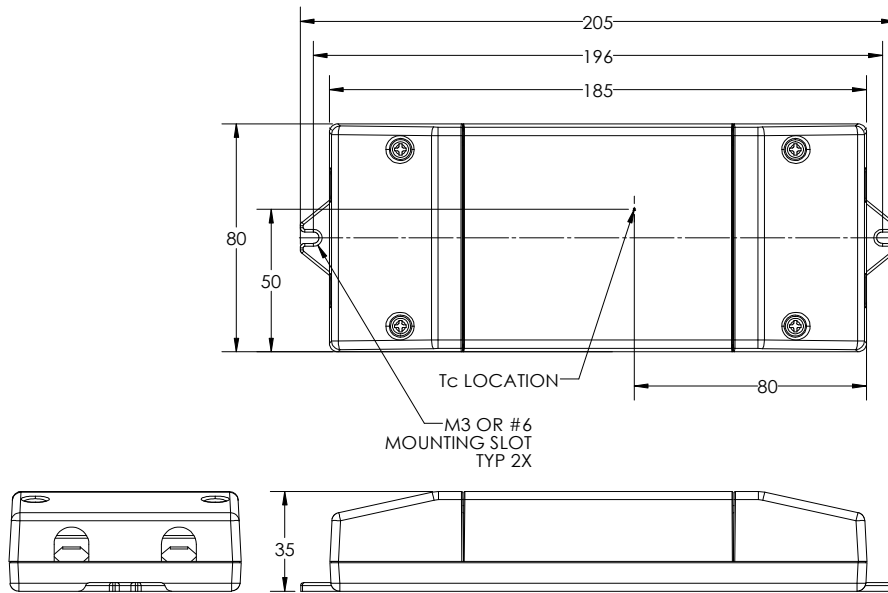

**LMD300 220- to 240-V Driver - With Optional Conduit Covers**

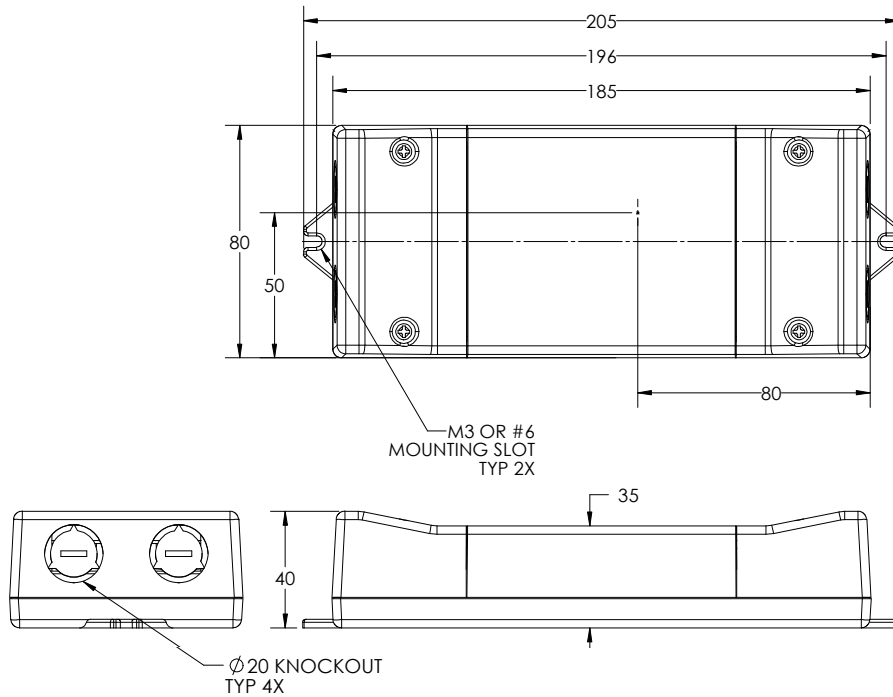

**LMD600 100- to 277-V Driver**

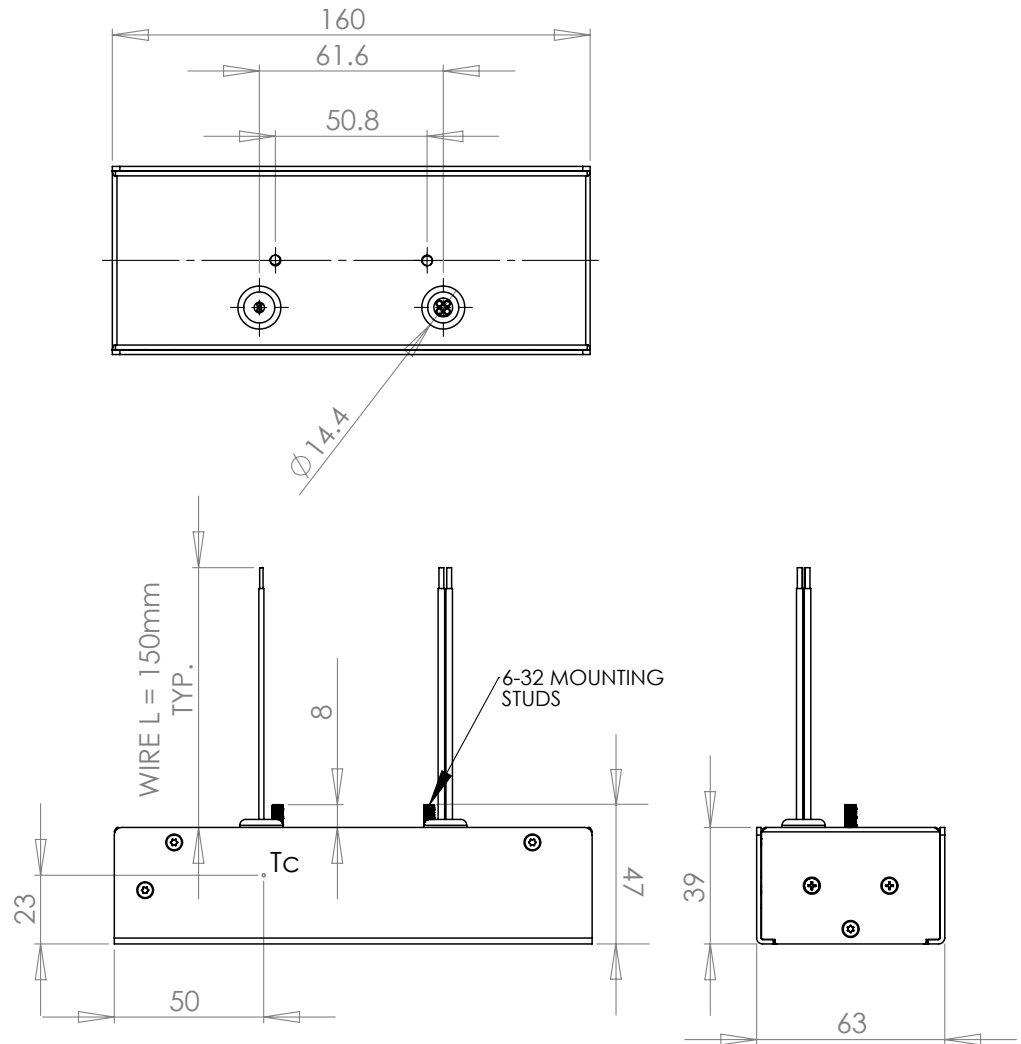

**WIRING DIAGRAMS**

**Electrical Connection**

For the 100- to 240-V, 100- to 277-V and 120- to 277-V LED module drivers, LMH2 LED module operation is accomplished by connecting the AC mains to the two (2) lead wires (line and neutral) from the driver and connecting the driver output wires to the input leads on the Cree LMH2 light source, as indicated in the following wiring diagrams. For the 220- to 240-V LED module drivers, module operation is accomplished by connecting the AC mains to the appropriate terminal block pins.

The 100- to 240-V and 120- to 277-V LED module driver lead wires are 152.4 mm long, 18 AWG with the ends stripped 10 mm. The 100- to 277-V LED module driver lead wires are 150 mm long, 18 AWG with the ends stripped 10 mm. The 220- to 240-V LED module drivers have poke-in terminals.

**LMD300 100- to 240-V Driver**

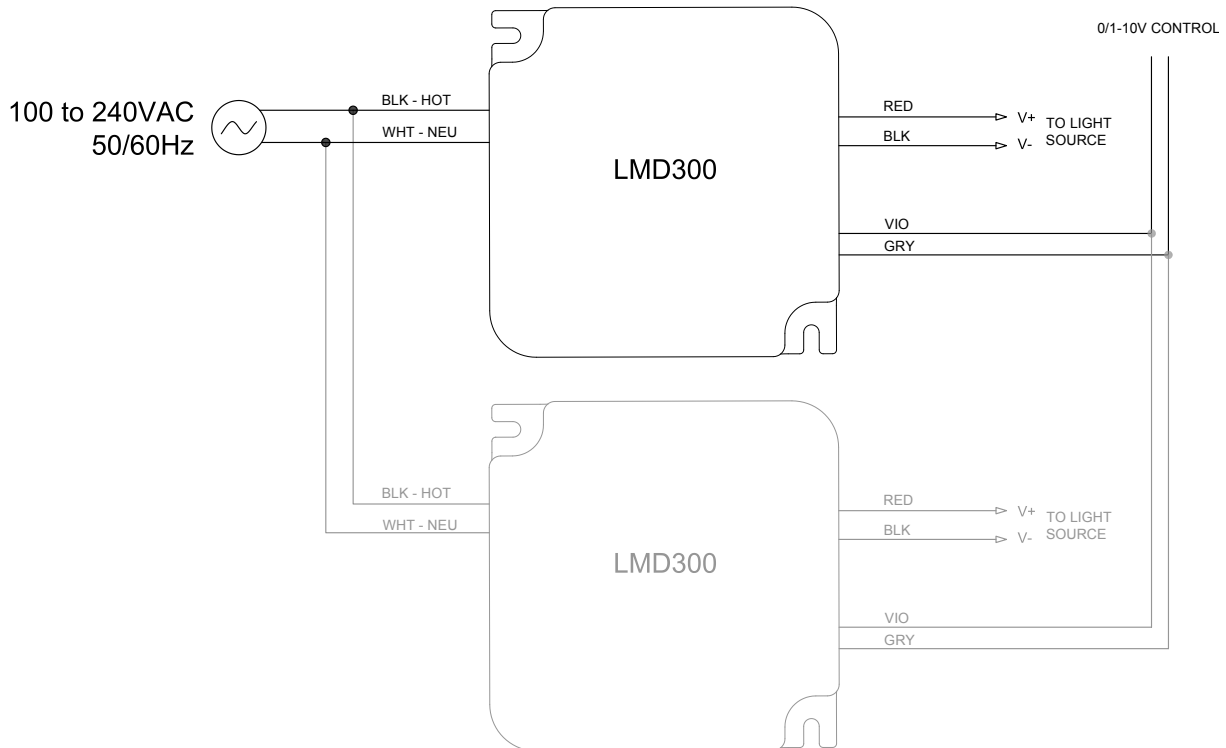

**LMD300 & LMD400 120- to 277-V Drivers**

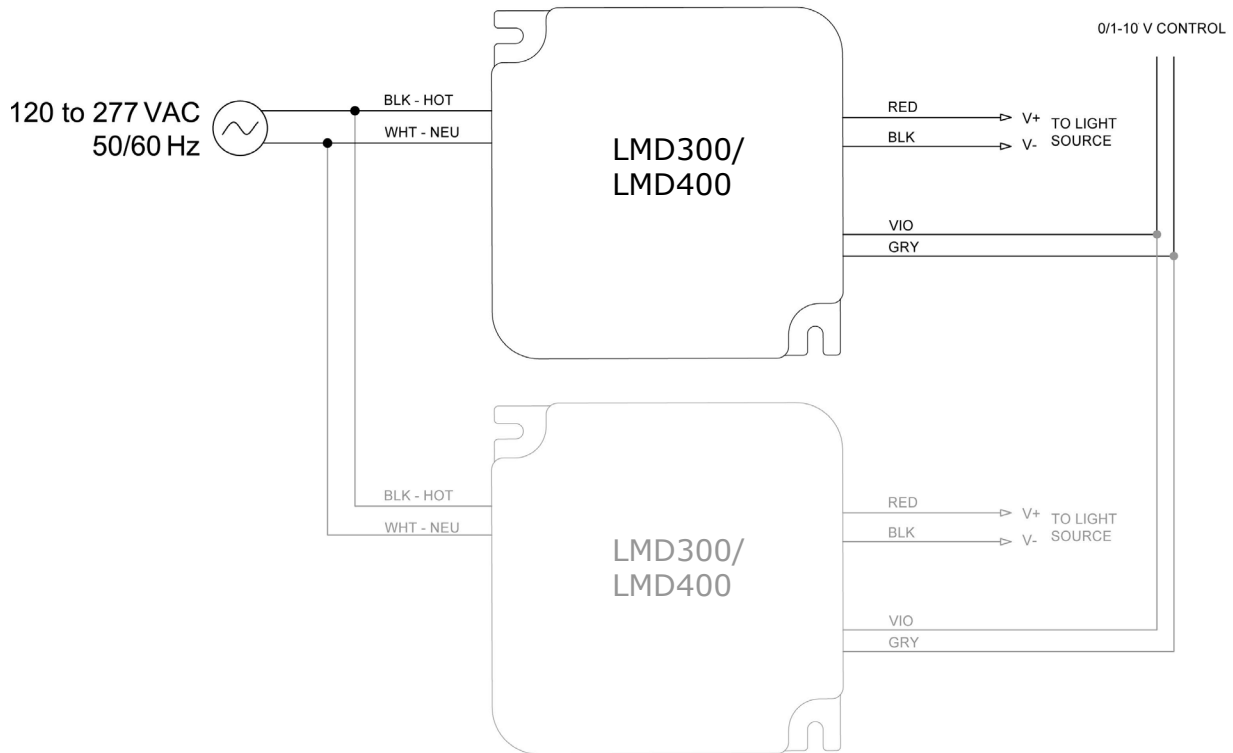

**LMD300 220- to 240-V 0/1 - 10 V and DALI + Touch Dimming Drivers - Touch Operation Not Required**

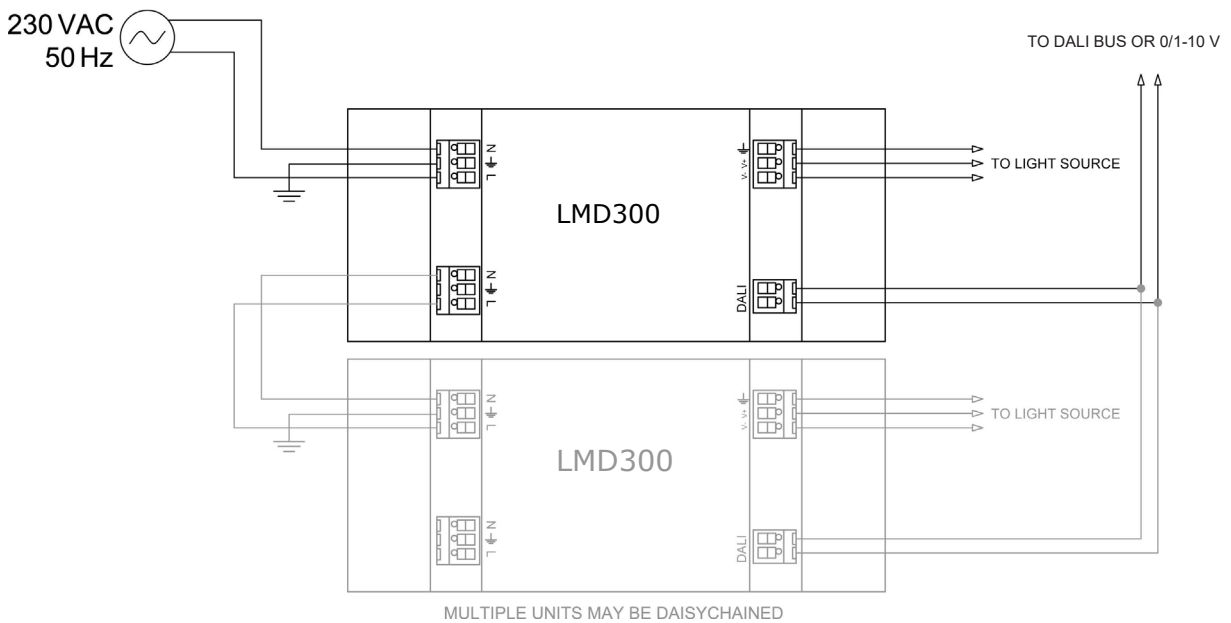

**LMD300 220- to 240-V DALI + Touch Driver**

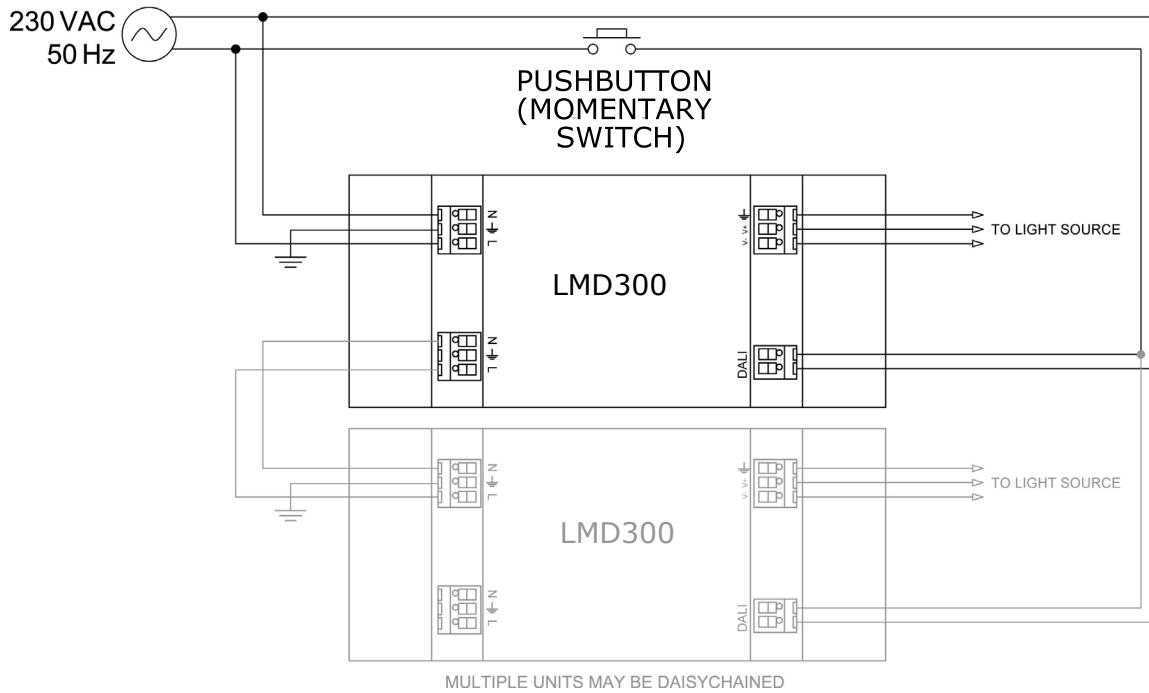

**LMD600 100- to 277-V Driver**

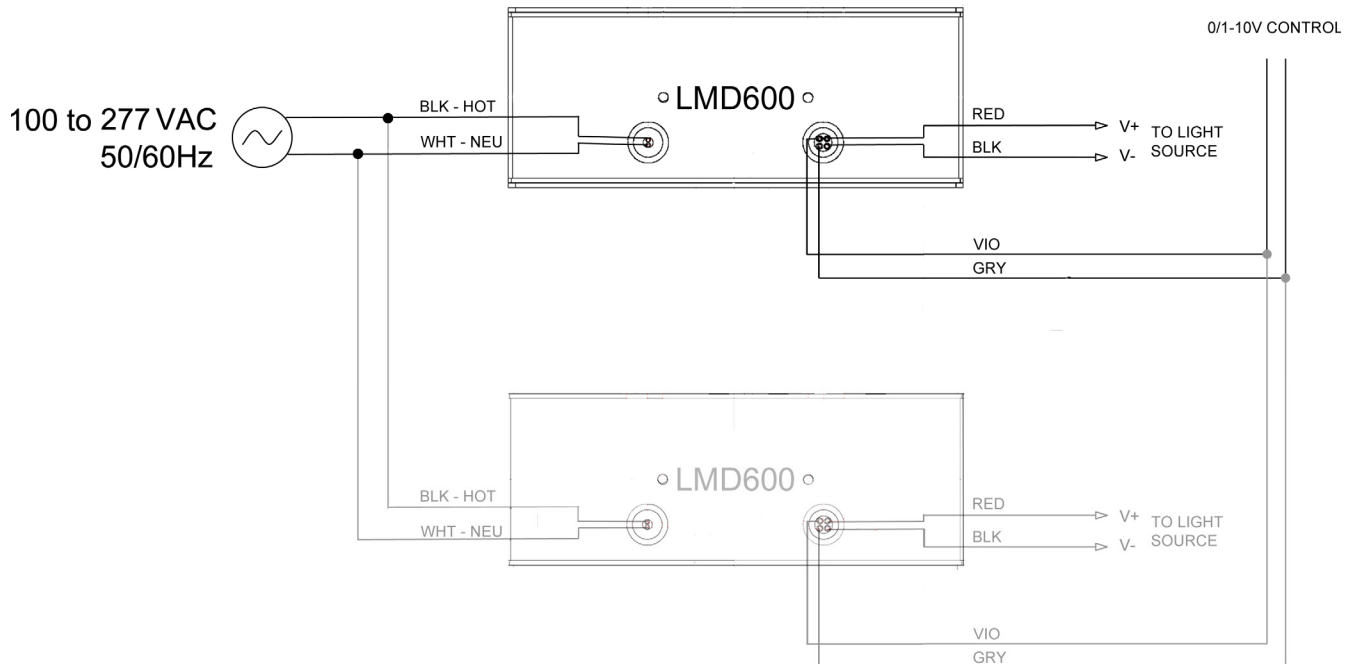

### Wiring Strain Relief

LMD300, LMD400 and LMD600 LED module drivers must not be suspended directly by the leads. Though the wiring from the LMD300, LMD400 and LMD600 LED module drivers is internally strain relieved, additional strain relief methods must be employed if the luminaire is to be suspended solely by the wiring, as in a pendant luminaire.

## THERMAL DESIGN

### Expected LMD300 Lifetime versus Temperature at Tc Point

Expected Operation Life (Hours)	Tc (°C) @ 25 °C Room Ambient			
	LMD300 100- to 240-V 0/1-10 V Dimming Driver	LMD300 120- to 277-V 0/1-10 V Dimming Driver	LMD300 220- to 240-V 0/1-10 V Dimming Driver	LMD300 220- to 240-V DALI + Touch Dimming Driver
35,000	70	70	70	70
50,000	65	65	65	65

### Expected LMD400 Lifetime versus Temperature at Tc Point

Expected Operation Life (Hours)	Tc (°C) @ 25 °C Room Ambient
	LMD400 120- to 277-V 0/1-10 V Dimming Driver
35,000	90
50,000	80

### Expected LMD600 Lifetime versus Temperature at Tc Point

Expected Operation Life (Hours)	Tc (°C) @ 25 °C Room Ambient
	LMD600 100- to 277-V 0/1-10 V Dimming Driver
50,000	76

## EMERGENCY BATTERY OPERATION

The LMD300, LMD400 and LMD600 LED module drivers are constant-current supplies. Interrupting the driver current with a battery supply is an acceptable method of emergency or power outage operation. An acceptable installation should also include a switching mechanism that prevents the battery power from entering the driver through the DC output leads. Confirming backup power supply compatibility is the responsibility of the luminaire manufacturer or installer. Please refer to the backup power supply manufacturer's instructions for installation and further product information.

**SAFETY AND REGULATORY NOTES**

The following tables show the safety and regulatory certifications for the LMD300 and LMD400 LED module drivers.

	LMD300 100- to 240-VAC Driver	
	Standard	File Number
Safety	J61347-1 (H20)	CJP2012109004-0578
	J61347-1 (H21)	
	EN 61347-1	CJP2012109004-0578
	EN 61347-2-13	
	CE SELV equivalent	
	IP-20	
Electromagnetic compatibility	EN 55015	CJP2012109004-0578
	IEC 61000-3-2	
	IEC 61000-3-3	
	IEC 61547	
Environmental	RoHs	

	LMD300 & LMD400 120- to 277-VAC Drivers		LMD300 220- to 240-VAC Driver	
	Standard	File Number	Standard	File Number
Safety	UL®/cUL recognized (UL8750)	E333437		
	Class 2 power supply			
	UL – Damp rated			
	Air handling (plenum)			
	5VA flame rating			
	EN 61347-1	RZCE2012-0221LVD 101342922CHI-001	EN 61347-1	RZCE2012-0205LVD RZCE2012-0512LVD RZCE2012-0574LVD-M1
	EN 61347-2-13		EN 61347-2-13	
	CE SELV equivalent		CE SELV equivalent	
	IP-20		IP-20	
Electromagnetic compatibility	EN 55015	RZCE2012-0221EMC R10051625-EMC	EN 55015	RZCE2012-0205EMC RZCE2012-0512EMC RZCE2012-0574EMC-M1
	IEC 61000-3-2		IEC 61000-3-2	
	IEC 61000-3-3		IEC 61000-3-3	
	IEC 61547		IEC 61547	
	FCC 47 CFR Part 15 Class B/ ICES 03			
Regulatory	IEEE C.62.41-1991 Class A (surge)			
	NEMA 410			
Environmental	RoHS		RoHS	

	LMD600 100- to 277-VAC Driver	
	Standard	File Number
Safety	UL/cUL recognized (UL8750)	E333437
	Class 2 power supply	
	UL – Damp rated	
	Air handling (plenum)	
	5VA flame rating	
	EN 61347-1	101564185CHI-001
	EN 61347-2-13	
	CE SELV equivalent	
	IP-20	
Electromagnetic compatibility	EN 55015	R10273893-EMC
	IEC 61000-3-2	
	IEC 61000-3-3	
	IEC 61547	
	FCC 47 CFR Part 15 Class B/ ICES 03	
Environmental	RoHS	

**Safety Certification**

Together, the LMH2 light source combined with the LMD300, LMD400 or LMD600 LED module driver is “suitable for damp locations; covered ceilings.” Final luminaire designs should go through safety certification as required, which is the responsibility of the luminaire manufacturer.

## PACKAGING

---

LMD300 100- to 240-V LED module drivers are packaged in boxes of 10, which are then combined in cartons of 5 boxes, or 50 LMD300 120- to 240-V drivers.

LMD300 and LMD400 120- to 277-V LED module drivers are packaged in boxes of 10, which are then combined in cartons of 5 boxes, or 50 LMD300 or LMD400 120- to 277-V drivers.

LMD300 220- to 240-V LED module drivers are packaged in boxes of 5, which are then combined in cartons of 10 boxes, or 50 LMD300 220- to 240-V drivers.

LMD600 100- to 277-V LED module drivers are packaged in boxes of 5, which are then combined in cartons of 5 boxes, or 25 LMD600 100- to 277-V drivers.

Box and carton sizes are as follows.

Box of 10 LMD300 100- to 240-V LED module drivers: 255 x 194 x 98 mm

Carton of 5 LMD300 100- to 240-V driver boxes: 509 x 275 x 222 mm

Box of 10 LMD300 or LMD400 120- to 277-V LED module drivers: 255 x 194 x 98 mm

Carton of 5 LMD300 or LMD400 120- to 277-V driver boxes: 509 x 275 x 222 mm

Box of 5 LMD300 220- to 240-V LED module drivers: 285 x 211 x 91 mm

Carton of 10 LMD300 220- to 240-V driver boxes: 588 x 471 x 243 mm

Box of 5 LMD600 100- to 277-V LED module drivers: 490 x 235 x 90 mm

Carton of 5 LMD600 100- to 270-V driver boxes: 510 x 510 x 255 mm