

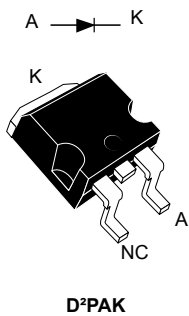

1200 V Automotive ultrafast recovery, high voltage diode



Features

- AEC-Q101 qualified 
- Ultrafast, soft recovery
- Very low conduction and switching losses
- High frequency and/or high pulsed current operation
- High reverse voltage capability
- High junction temperature
- ECOPACK[®] compliant

Applications

- On Board Battery charger (OBC)
- Surge bypass diodes

Description

The high quality design of this diode has produced a device with low leakage current, regularly reproducible characteristics and intrinsic ruggedness. These characteristics make it ideal for heavy duty applications that demand long term reliability.

The improved performance in low leakage current, and therefore thermal runaway guard band, is an immediate competitive advantage for this device for automotive applications.

Product status link

[STTH1512-Y](#)

Product summary

$I_{F(AV)}$	15 A
V_{RRM}	1200 V
V_F (typ.)	1.20 V
t_{rr} (typ.)	53 ns
T_j	-40 °C to 175 °C

1 Characteristics

Table 1. Absolute ratings (limiting values, at 25 °C, unless otherwise specified)

Symbol	Parameter	Value	Unit
V_{RRM}	Repetitive peak reverse voltage	1200	V
$I_{F(RMS)}$	Forward rms current	50	A
$I_{F(AV)}$	Average forward current $\delta = 0.5$, square wave	$T_C = 130\text{ °C}$	A
I_{FRM}	Repetitive peak forward current	$t_p = 5\ \mu\text{s}$, $F = 5\text{ kHz}$ square	A
I_{FSM}	Surge non repetitive forward current	$t_p = 10\text{ ms}$ sinusoidal	A
T_{stg}	Storage temperature range	-65 to +175	°C
T_j	Operating junction temperature range	-40 to +175	°C

Table 2. Thermal parameters

Symbol	Parameter	Max. value	Unit
$R_{th(j-c)}$	Junction to case	1.3	°C/W

For more information, please refer to the following application note :

- AN5088 : Rectifiers thermal management, handling and mounting recommendations

Table 3. Static electrical characteristics

Symbol	Parameter	Test conditions	Min.	Typ.	Max.	Unit	
$I_R^{(1)}$	Reverse leakage current	$T_j = 25\text{ °C}$	$V_R = V_{RRM}$	-		15	μA
		$T_j = 150\text{ °C}$		-	10	100	
$V_F^{(2)}$	Forward voltage drop	$T_j = 25\text{ °C}$	$I_F = 15\text{ A}$	-		2.10	V
		$T_j = 150\text{ °C}$		-	1.25	1.90	
		$T_j = 150\text{ °C}$		-	1.20	1.80	

1. Pulse test: $t_p = 5\text{ ms}$, $\delta < 2\%$

2. Pulse test: $t_p = 380\ \mu\text{s}$, $\delta < 2\%$

To evaluate the conduction losses, use the following equation:

$$P = 1.4 \times I_{F(AV)} + 0.027 \times I_F^2 \text{ (RMS)}$$

Table 4. Dynamic electrical characteristics

Symbol	Parameter	Test conditions		Min.	Typ.	Max.	Unit
t_{rr}	Reverse recovery time	$T_j = 25\text{ °C}$	$I_F = 1\text{ A}, V_R = 30\text{ V}, dI_F/dt = -50\text{ A}/\mu\text{s}$	-		105	ns
			$I_F = 1\text{ A}, V_R = 30\text{ V}, dI_F/dt = -100\text{ A}/\mu\text{s}$	-	53	75	
I_{RM}	Reverse recovery current	$T_j = 125\text{ °C}$	$I_F = 15\text{ A}, V_R = 600\text{ V}, dI_F/dt = -200\text{ A}/\mu\text{s}$	-	20	28	A
S_{factor}	Softness factor	$T_j = 125\text{ °C}$	$I_F = 15\text{ A}, V_R = 600\text{ V}, dI_F/dt = -200\text{ A}/\mu\text{s}$	-	1.5		
t_{rr}	Reverse recovery time	$T_j = 25\text{ °C}$	$I_F = 15\text{ A}, V_{FR} = 1.5 \times V_{Fmax}, dI_F/dt = 50\text{ A}/\mu\text{s}$	-		600	ns
V_{FP}	Forward recovery voltage	$T_j = 25\text{ °C}$	$I_F = 15\text{ A}, dI_F/dt = 50\text{ A}/\mu\text{s}$		5.5		V

For more information, please refer to the following application notes related to the power losses:

- AN604: Calculation of conduction losses in a power rectifier
- AN4021: Calculation of reverse losses in a power diode

1.1 Characteristic (curves)

Figure 1. Conduction losses versus average current

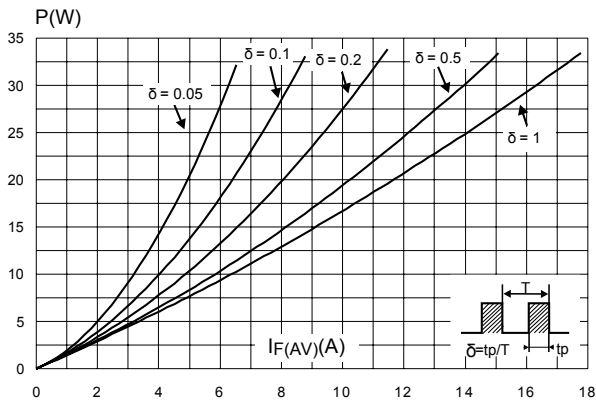

Figure 2. Forward voltage drop versus forward current

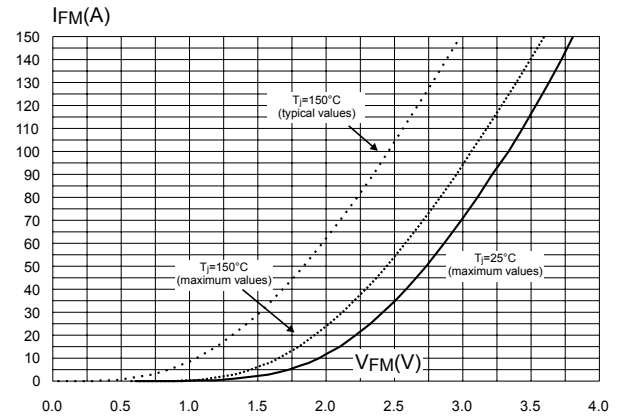

Figure 3. Relative variation of thermal impedance junction to case versus pulse duration

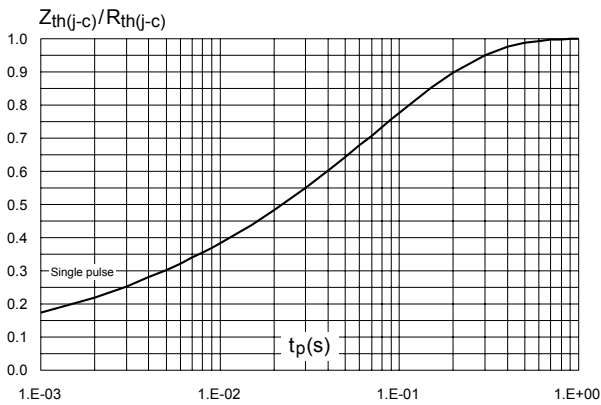

Figure 4. Peak reverse recovery current versus di_F/dt (typical values)

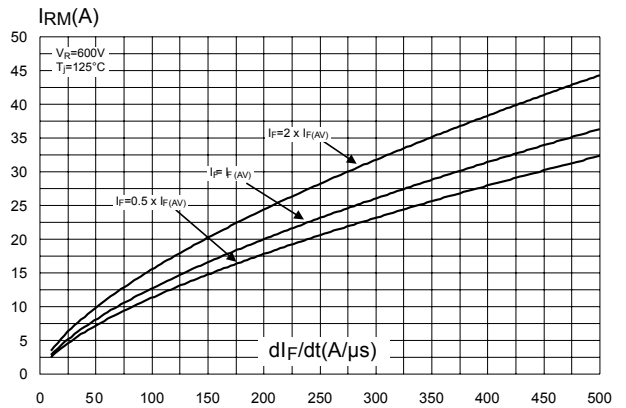

Figure 5. Reverse recovery time versus di_F/dt (typical values)

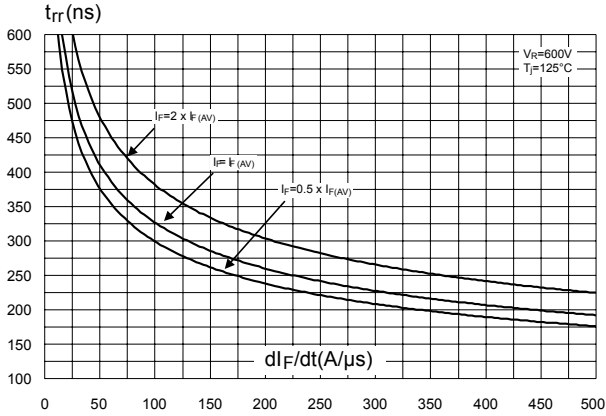

Figure 6. Reverse recovery time versus di_F/dt (typical values)

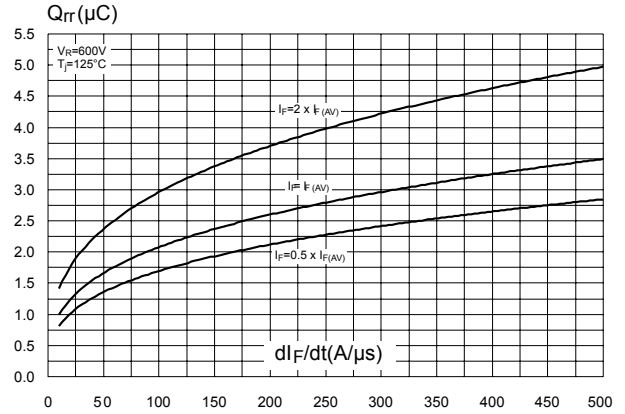

Figure 7. Reverse recovery softness factor versus di_F/dt (typical values)

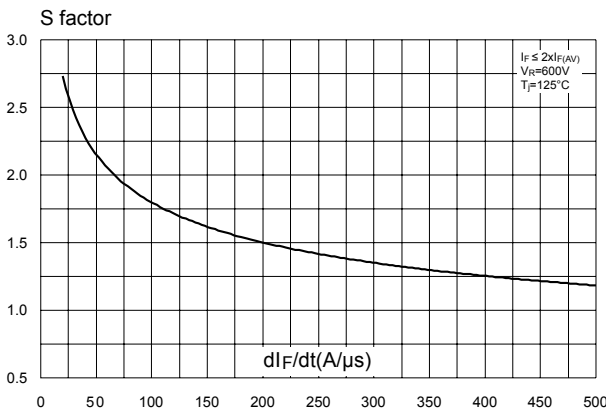

Figure 8. Relative variations of dynamic parameters versus junction temperature

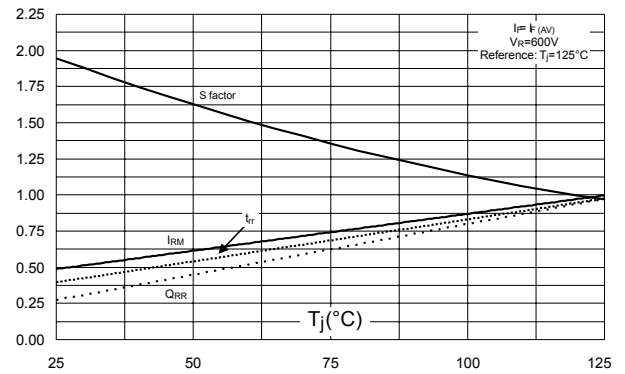

Figure 9. Transient peak forward voltage versus di_F/dt (typical values)

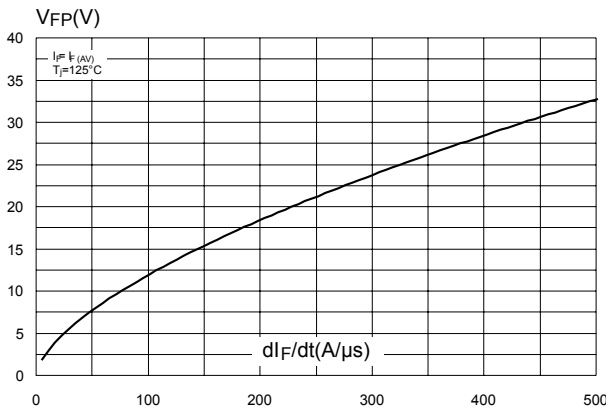

Figure 10. Forward recovery time versus di_F/dt (typical values)

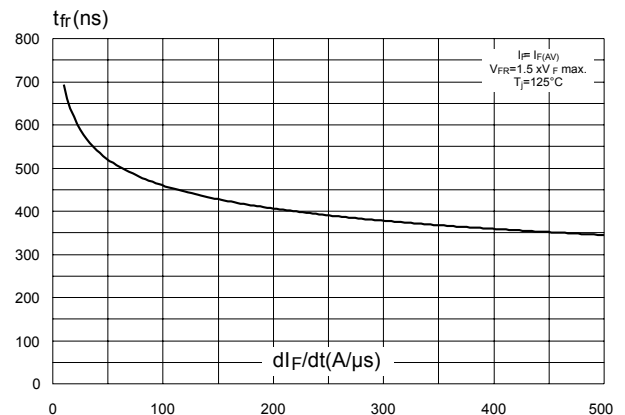

Figure 11. Junction capacitance versus reverse voltage applied (typical values)

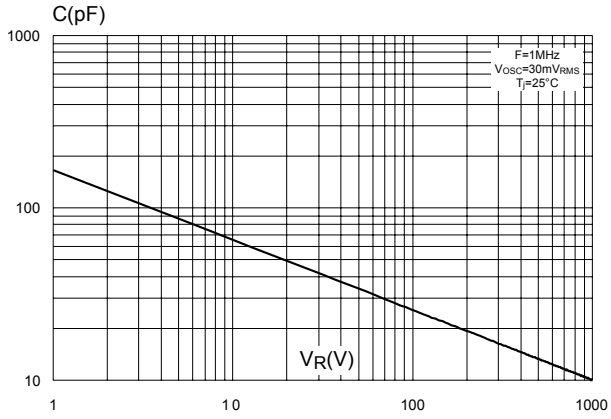
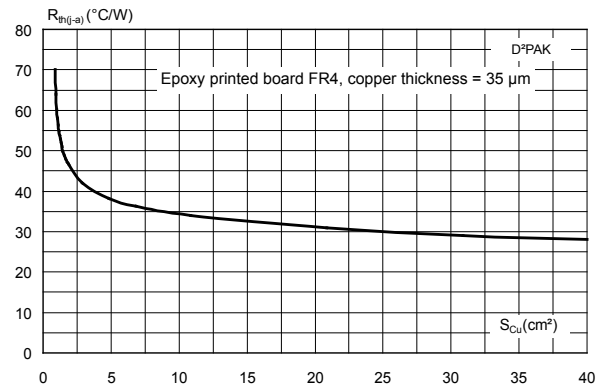

Figure 12. Thermal resistance junction to ambient versus copper surface under each lead



2 Package information

In order to meet environmental requirements, ST offers these devices in different grades of ECOPACK® packages, depending on their level of environmental compliance. ECOPACK® specifications, grade definitions and product status are available at: www.st.com. ECOPACK® is an ST trademark.

2.1 D²PAK package information

- Epoxy meets UL94, V0
- Cooling method: by conduction (C)

Figure 13. D²PAK package outline

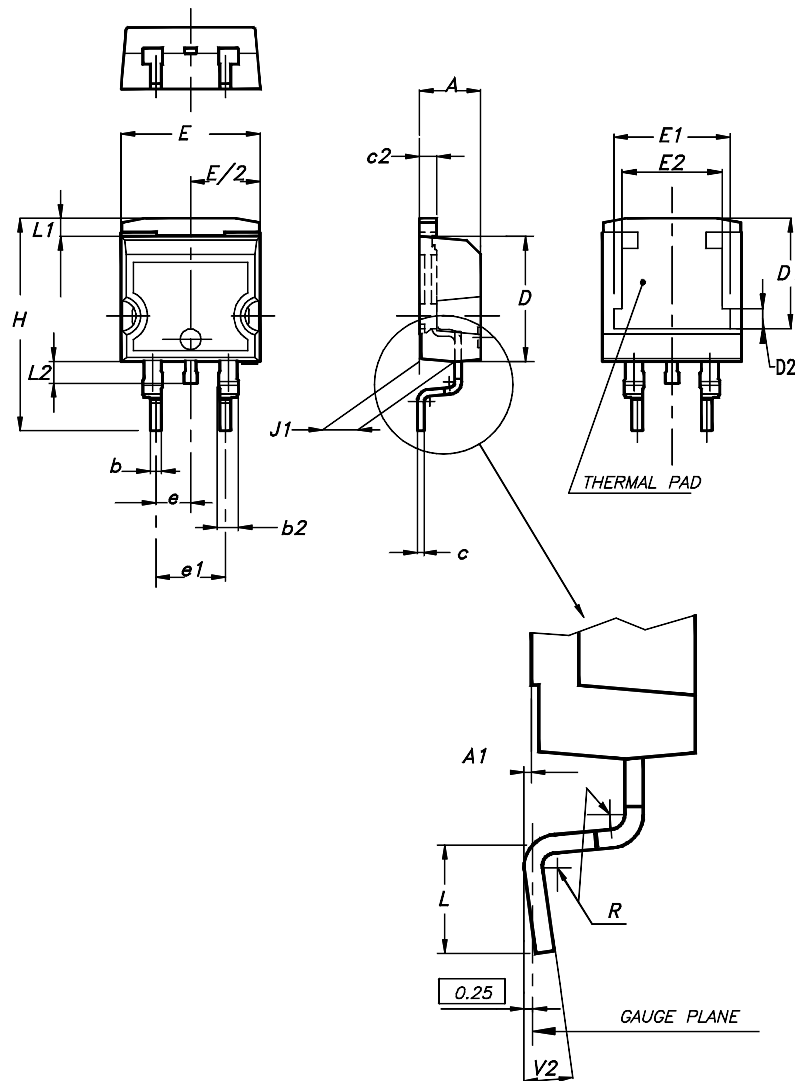

Note: This package drawing may slightly differ from the physical package. However, all the specified dimensions are guaranteed.

Table 5. D²PAK package mechanical data

Ref.	Dimensions			
	Millimeters		Inches (for reference only)	
	Min.	Max.	Min.	Max.
A	4.36	4.60	0.172	0.181
A1	0.00	0.25	0.000	0.010
b	0.70	0.93	0.028	0.037
b2	1.14	1.70	0.045	0.067
c	0.38	0.69	0.015	0.027
c2	1.19	1.36	0.047	0.053
D	8.60	9.35	0.339	0.368
D1	6.90	8.00	0.272	0.311
D2	1.10	1.50	0.043	0.060
E	10.00	10.55	0.394	0.415
E1	8.10	8.90	0.319	0.346
E2	6.85	7.25	0.266	0.282
e	2.54 typ.		0.100	
e1	4.88	5.28	0.190	0.205
H	15.00	15.85	0.591	0.624
J1	2.49	2.90	0.097	0.112
L	1.90	2.79	0.075	0.110
L1	1.27	1.65	0.049	0.065
L2	1.30	1.78	0.050	0.070
R	0.4 typ.		0.015	
V2	0°	8°	0°	8°

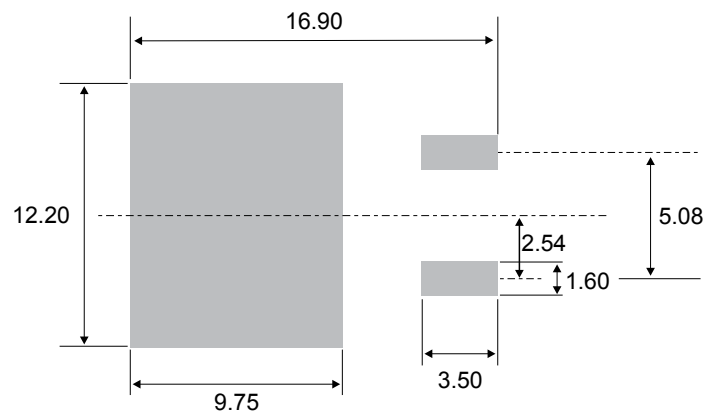
Figure 14. D²PAK recommended footprint (dimensions in mm)

3 Ordering information

Table 6. Ordering information

Order code	Marking	Package	Weight	Base qty.	Delivery mode
STTH1512GY-TR	STTH1512GY	D ² PAK	1.48 g	1000	Tape and reel

Revision history

Table 7. Document revision history

Date	Revision	Changes
11-Jul-2013	1	Initial release.
21-Nov-2018	2	Added Section Applications . Updated Table 6 . Ordering information.

IMPORTANT NOTICE – PLEASE READ CAREFULLY

STMicroelectronics NV and its subsidiaries (“ST”) reserve the right to make changes, corrections, enhancements, modifications, and improvements to ST products and/or to this document at any time without notice. Purchasers should obtain the latest relevant information on ST products before placing orders. ST products are sold pursuant to ST’s terms and conditions of sale in place at the time of order acknowledgement.

Purchasers are solely responsible for the choice, selection, and use of ST products and ST assumes no liability for application assistance or the design of Purchasers’ products.

No license, express or implied, to any intellectual property right is granted by ST herein.

Resale of ST products with provisions different from the information set forth herein shall void any warranty granted by ST for such product.

ST and the ST logo are trademarks of ST. All other product or service names are the property of their respective owners.

Information in this document supersedes and replaces information previously supplied in any prior versions of this document.

© 2018 STMicroelectronics – All rights reserved