



Main

Range of product	OsiSense XM
Pressure sensor type	Electromechanical pressure sensor
Pressure sensor name	XMP
Pressure sensor size	174.05 psi (12 bar)
Fluid connection type	G 3/8 (female) ISO 228
Controlled fluid	Air 32...158 °F (0...70 °C)) Fresh water 32...158 °F (0...70 °C)) Sea water 32...158 °F (0...70 °C))
Cable entry	2 entries incorporating Pg 13.5 plastic cable gland 0.35...0.51 in (9...13 mm) NF C 68-300
Contacts type and composition	3 NC snap action
Product specific application	-
Pressure switch type of operation	Regulation between 2 thresholds
Electrical connection	Screw-clamp terminals minimum : 2 x 4 mm ²
Electrical circuit type	Power circuit
Scale type	Adjustable differential
Local display	Without
Sale per indivisible quantity	1

Complementary

Adjustable range of switching point on falling pressure	4.35...149.39 psi (0.3...10.3 bar)
Adjustment range high setting	18.85...174.05 psi (1.3...12 bar)
Possible differential minimum at low setting	14.50 psi (1 bar)
Possible differential minimum at high setting	24.66 psi (1.7 bar)
Possible differential maximum at high setting	121.83 psi (8.4 bar)
Destruction pressure	435.11 psi (30 bar)
Type of decompression valve	Without
Control type	Without
Terminal block type	6 terminals
Pressure actuator	Diaphragm
Materials in contact with fluid	Chromated zinc alloy Canvas covered nitrile
Enclosure material	PA impregnated with fibreglass
Operating position	Any position
Maximum operating rate	10 cyc/mn
Repeat accuracy	3.5 %
[Ui] rated insulation voltage	500 V EN/IEC 60947-1
[Uimp] rated impulse withstand voltage	6 kV EN/IEC 60947-1
Maximum resistance across terminals	25 MOhm IEC 60255-7 category 3 25 MOhm NF C 93-050 method A
Electrical durability	1000000 Cycles 1.5 kW 10 cyc/mn 0.4, 400 V AC 3 phase 500000 Cycles 3 kW 10 cyc/mn 0.4, 400 V AC 3 phase 600000 Cycles 1.5 kW 10 cyc/mn 0.4, 230 V AC 3 phase 700000 cycles 2.2 kW 10 cyc/mn 0.4, 400 V AC 3 phase
Mechanical durability	1000000 cycles

Setting	Knurled knob and nut
Net Weight	0.95 lb(US) (0.43 kg)
Terminals description ISO n°1	(3-4)NC (5-6)NC (1-2)NC
Depth	3.86 in (98 mm)
Height	4.17 in (106 mm)
Maximum Width	2.24 in (57 mm)

Environment

Product certifications	EAC
Standards	EN/IEC 60947-4-1 CE
Ambient air temperature for operation	-13...158 °F (-25...70 °C)
Ambient air temperature for storage	-40...158 °F (-40...70 °C)
Vibration resistance	3 gn 10...500 Hz)IEC 60068-2-6
Shock resistance	50 gn IEC 60068-2-27
Electrical shock protection class	Class I IEC 60536
IP degree of protection	IP54 EN/IEC 60529

Ordering and shipping details

Category	22661 - XMLA,B,C,D PRESSURE SWITCHES
Discount Schedule	DS2
GTIN	03389110349030
Nbr. of units in pkg.	1
Package weight(Lbs)	1.09 lb(US) (0.49 kg)
Returnability	No
Country of origin	CZ

Packing Units

Unit Type of Package 1	PCE
Package 1 Height	2.52 in (6.4 cm)
Package 1 width	6.77 in (17.2 cm)
Package 1 Length	4.49 in (11.4 cm)
Unit Type of Package 2	S03
Number of Units in Package 2	20
Package 2 Weight	24.11 lb(US) (10.935 kg)
Package 2 Height	11.81 in (30 cm)
Package 2 width	11.81 in (30 cm)
Package 2 Length	15.75 in (40 cm)
Unit Type of Package 3	P06
Number of Units in Package 3	160
Package 3 Weight	216.50 lb(US) (98.204 kg)
Package 3 Height	30.31 in (77 cm)
Package 3 width	23.62 in (60 cm)
Package 3 Length	31.50 in (80 cm)

Offer Sustainability

Sustainable offer status	Green Premium product
California proposition 65	WARNING: This product can expose you to chemicals including: Diisononyl phthalate (DINP), which is known to the State of California to cause cancer, and Di-isodecyl phthalate (DIDP), which is known to the State of California to cause birth defects or other reproductive harm. For more information go to www.P65Warnings.ca.gov
REACH Regulation	REACH Declaration
EU RoHS Directive	Pro-active compliance (Product out of EU RoHS legal scope) EU RoHS Declaration
Mercury free	Yes
RoHS exemption information	Yes
Environmental Disclosure	Product Environmental Profile

Contractual warranty

Warranty	18 months
----------	-----------

Dimensions

Without Decompression Valve

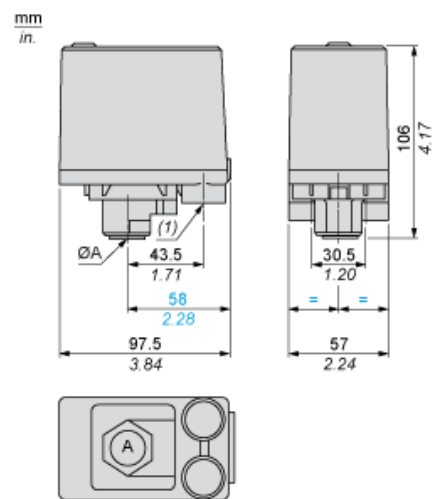

ØA = G 3/8

(1) 2 tapped entries for Pg 13.5

Minimum Mounting Clearance

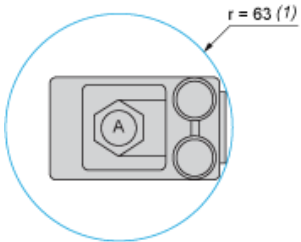

ØA = G 3/8

(1) Minimum clearance zone for screwing-on pressure switch at point A

Wiring Diagram

Terminal Connections

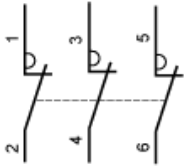

Curves

Operating Curves

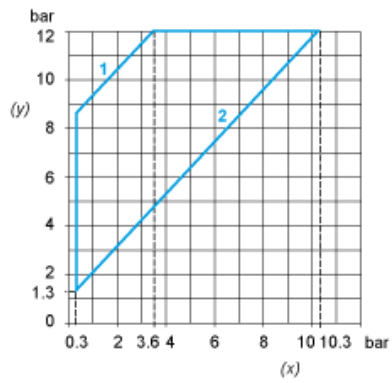

- (y) Rising pressure
- (x) Falling pressure
- 1 : Maximum differential
- 2 : Minimum differential

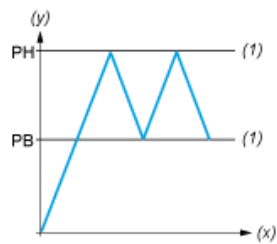

- (y) Pressure
- (x) Time
- (1) Adjustable value
- PH : High point
- PB : Below point