

XUZASK004

accessory for sensor - XUK laser + TOF -
angle bracket fixing fine adjustable



Main

Range of product	OsiSense XU
Accessory / separate part category	Mounting and fixing accessory
Accessory / separate part type	Fixing bracket
Product or component type	Fixing bracket
Accessory / separate part destination	Compact sensor 50 x 50 mm
Material	Metal

Complementary

Product compatibility	XUK8LAPPNM12 XUK9LAPSMM12 XUK2LAKSMM12T XUK5LAPSMM12 XUK8TAKSMM12 XUK8TAKDMM12 XUK2LAPSMM12R XUK9TAH2MM12 XUK8TAE1MM12 XUK8TAE2MM12
Net Weight	0.53 lb(US) (0.24 kg)



Ordering and shipping details

Category	22499 - SENSORS ACCESSORIES
Discount Schedule	DS2
GTIN	00785901464709
Nbr. of units in pkg.	1
Package weight(Lbs)	1 lb(US) (0.45 kg)
Returnability	No
Country of origin	DE

Packing Units

Unit Type of Package 1	PCE
Package 1 Height	2.17 in (5.5 cm)
Package 1 width	3.90 in (9.9 cm)
Package 1 Length	2.80 in (7.1 cm)
Unit Type of Package 2	S01
Number of Units in Package 2	25
Package 2 Weight	7.22 lb(US) (3.275 kg)
Package 2 Height	5.91 in (15 cm)
Package 2 width	5.91 in (15 cm)
Package 2 Length	15.75 in (40 cm)

Offer Sustainability

California proposition 65	WARNING: This product can expose you to chemicals including: Diisononyl phthalate (DINP), which is known to the State of California to cause cancer, and Di-isodecyl phthalate (DIDP), which is known to the State of California to cause birth defects or other reproductive harm. For more information go to www.P65Warnings.ca.gov
EU RoHS Directive	Pro-active compliance (Product out of EU RoHS legal scope)  EU RoHS Declaration
Toxic heavy metal free	Yes
Mercury free	Yes
RoHS exemption information	 Yes

Contractual warranty

Warranty	18 months
----------	-----------

Dimensions

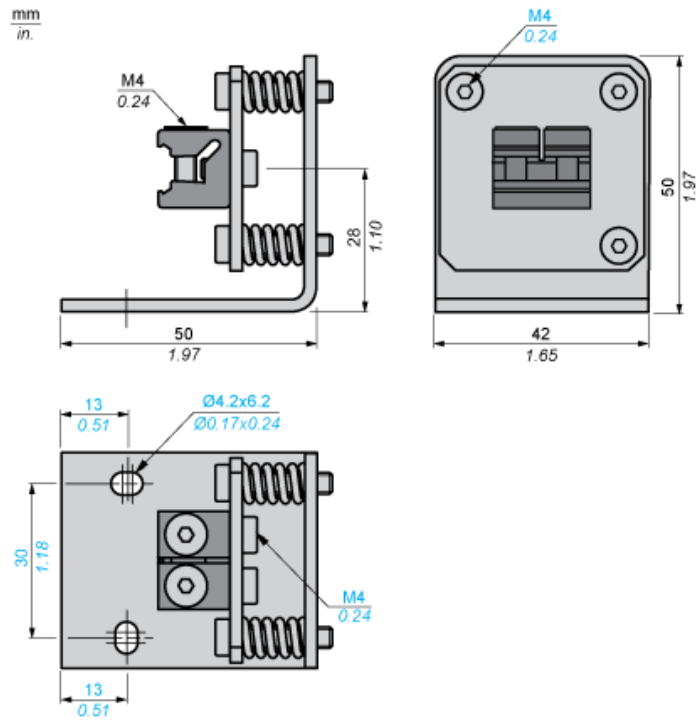

Mounting

