

Main

Range of product	Preventa Safety detection
Accessory / separate part category	Spare parts
Accessory / separate part type	Anti-vibration kit
Product compatibility	XUSL4E XUSL2E
Accessory / separate part destination	Safety light curtain type 4 Safety light curtain type 2
Height protected	6.30 in (160 mm)

Complementary

Kit composition	4 damper(s)
Net Weight	0.11 lb(US) (0.05 kg)

Ordering and shipping details

Category	22455 - LIGHT CURTAINS - XUSL
Discount Schedule	DS2
GTIN	03389119619028
Nbr. of units in pkg.	1
Package weight(Lbs)	1 lb(US) (0.45 kg)
Returnability	No
Country of origin	IT

Packing Units

Package 1 Height	0.200 dm
Package 1 width	1.200 dm
Package 1 Length	1.800 dm

Offer Sustainability

Sustainable offer status	Green Premium product
California proposition 65	WARNING: This product can expose you to chemicals including: Diisononyl phthalate (DINP), which is known to the State of California to cause cancer, and Di-isodecyl phthalate (DIDP), which is known to the State of California to cause birth defects or other reproductive harm. For more information go to www.P65Warnings.ca.gov
REACH free of SVHC	Yes
EU RoHS Directive	Pro-active compliance (Product out of EU RoHS legal scope) EU RoHS Declaration
Toxic heavy metal free	Yes
Mercury free	Yes
RoHS exemption information	Yes
Environmental Disclosure	Product Environmental Profile
Circularity Profile	End Of Life Information

Dimensions

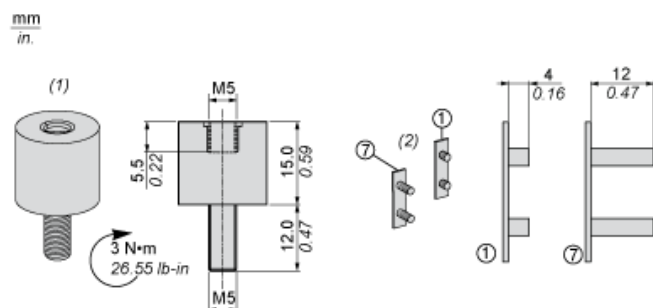

Mounting and Clearance

