



350W Slim Type with PFC Switching Power Supply

# UHP-350 series



## Features

- Slim Low profile (31mm)
- Fanless design,350W convection
- Withstand 300VAC surge input for 5 seconds
- Built-in active PFC function
- -30~+70°C working temperature
- Protections: Short circuit / Overload / Over voltage / Over temperature
- DC OK active signal and redundant function(option)
- Operating altitude up to 5000 meter (Note.5)
- LED indicator for power on
- 3 years warranty

## Applications

- Industrial automation machinery
- Industrial control system
- Mechanical and electrical equipment
- Electronic instruments, equipments or apparatus
- Household appliances
- LED display application
- Power Source Equipment for PoE(55V model)

## GTIN CODE

MW Search: <https://www.meanwell.com/serviceGTIN.aspx>

## Description

UHP-350 series is a 350W single-output slim type power supply with 31mm of low profile design. Adopting the full range 90~264VAC input, the entire series provides an output voltage line of 3.3V, 4.2V, 5V, 12V, 15V, 24V, 36V,48V and 55V. In addition to the high efficiency up to 94%, that the whole series operates from -30°C ~ 70°C under air convection without fan. UHP-350 has the complete protection functions and 5G anti-vibration capability;It is complied with the international safety regulations such as TUV BS EN/EN62368-1, BS EN/EN60335-1, UL 62368-1 and GB4943. UHP-350 series serves as a high performance power supply solution for various industrial applications.

## Model Encoding

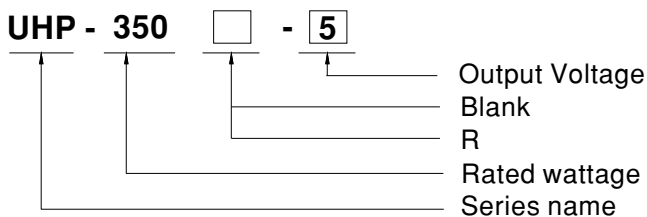

Type	Description	Note
Blank	Enclosed	In Stock
R	Built-in DC OK active signal and redundant function.	In Stock



**SPECIFICATION**

MODEL		UHP-350□-3.3	UHP-350□-4.2	UHP-350□-5	UHP-350□-12	UHP-350□-15	UHP-350□-24	UHP-350□-36	UHP-350□-48	UHP-350□-55	
OUTPUT	DC VOLTAGE	3.3V	4.2V	5V	12V	15V	24V	36V	48V	55V	
	RATED CURRENT	60A	60A	60A	29.2A	23.4A	14.6A	9.75A	7.3A	6.3A	
	RATED POWER	198W	252W	300W	350.4W	351W	350.4W	351W	350.4W	350W	
	RIPPLE & NOISE (max.) Note.2	150mVp-p	150mVp-p	200mVp-p	200mVp-p	200mVp-p	240mVp-p	240mVp-p	240mVp-p	300mVp-p	
	VOLTAGE ADJ. RANGE	3.2~3.5V	3.6~4.4V	4.5~5.5V	11.4~12.6V	14.3~15.8V	22.8~25.2V	34.2~37.8V	45.6~50.4V	45~58V	
	VOLTAGE TOLERANCE Note.3	±2.0%	±2.0%	±2.0%	±1.0%	±1.0%	±1.0%	±1.0%	±1.0%	±1.0%	
	LINE REGULATION	±0.5%	±0.5%	±0.5%	±0.3%	±0.3%	±0.3%	±0.3%	±0.3%	±0.3%	
	LOAD REGULATION	±1.0%	±1.0%	±1.0%	±0.5%	±0.5%	±0.5%	±0.5%	±0.5%	±0.5%	
	SETUP, RISE TIME	2000ms, 80ms/230VAC; 3000ms, 80ms/115VAC at full load; 550ms/230VAC for 55V setup time									
	HOLD UP TIME (Typ.)	10ms/230VAC 10ms/115VAC									
INPUT	VOLTAGE RANGE Note.4	90 ~ 264VAC		127 ~ 370VDC							
	FREQUENCY RANGE	47 ~ 63Hz									
	POWER FACTOR (Typ.)	PF≥0.94/230VAC PF≥0.98/115VAC at full load									
	EFFICIENCY (Typ.) Note.7	88.5%	89%	90%	91%	92%	94%	94%	94%	94%	
	AC CURRENT (Typ.)	4A/115VAC		2A/230VAC							
	INRUSH CURRENT (Typ.)Note.8	Cold start 30A/115VAC		60A/230VAC							
	LEAKAGE CURRENT	<0.75mA / 240VAC									
PROTECTION	OVERLOAD	110~140% rated output power Protection type : Hiccup mode, recovers automatically after fault condition is removed									
	OVER VOLTAGE	3.8 ~ 4.6V	4.62 ~ 5.46V	5.75 ~ 6.75V	13.2 ~ 15.6V	16.5 ~ 19.5V	26.4 ~ 31.2V	39.6 ~ 46.8V	52.8 ~ 62.4V	60 ~ 69V	
		Protection type : Shut down O/P voltage, re-power on to recover									
	OVER TEMPERATURE	Protection type : Shut down O/P voltage, recovers automatically after temperature goes down									
FUNCTION	DC OK SIGNAL(Optional)	Contact rating(max.):15Vdc/10mA resistive load									
	REDUNDANT(Optional)	For parallel connection protection:For parallel applications, when one PSU can not work , the another one will be automatically enabled. This can prevent the system crash, and provide the reliability of system									
ENVIRONMENT	WORKING TEMP.	-30 ~ +70°C (Refer to "Derating Curve")									
	WORKING HUMIDITY	20 ~ 95% RH non-condensing									
	STORAGE TEMP., HUMIDITY	-40 ~ +85°C, 10 ~ 95% RH non-condensing									
	TEMP. COEFFICIENT	±0.03%/°C (0 ~ 50°C)									
	VIBRATION	10 ~ 500Hz, 5G 10min./1cycle, 60min. each along X, Y, Z axes									
SAFETY & EMC (Note.6)	SAFETY STANDARDS	UL 62368-1, TUV EN62368-1, BS EN/EN60335-1(Except for 55V), CCC GB4943, BSMI CNS14336-1, EAC TP TC 004 approved, Design refer to BS EN/EN61558-1, -2-16									
	WITHSTAND VOLTAGE	I/P-O/P:3.75KVAC I/P-FG:2KVAC O/P-FG:1.25KVAC									
	ISOLATION RESISTANCE	I/P-O/P, I/P-FG, O/P-FG:100M Ohms/500VDC/25°C/ 70%RH									
	EMC EMISSION	Compliance to BS EN/EN55032, GB9254, Class B, BS EN/EN55014, BS EN/EN61000-3-2, -3, BSMI CNS13438, EAC TP TC 020									
	EMC IMMUNITY	Compliance to BS EN/EN61000-4-2, 3, 4, 5, 6, 8, 11; BS EN/EN61000-6-2 (BS EN/EN50082-2), BS EN/EN55035, heavy industry level , EAC TP TC 020									
OTHERS	MTBF	1791.2 K hrs min. Telcordia SR-332 (Bellcore) ; 253.4K hrs min. MIL-HDBK-217F (25°C)									
	DIMENSION	220*62*31mm (L*W*H)									
	PACKING	0.68 kg; 16 pcs/11.88 kg/0.63CUFT									
NOTE	<ol style="list-style-type: none"> <li>All parameters NOT specially mentioned are measured at 230VAC input, rated load and 25°C of ambient temperature.</li> <li>Ripple &amp; noise are measured at 20MHz of bandwidth by using a 12" twisted pair-wire terminated with a 0.1uf &amp; 47uf parallel capacitor.</li> <li>Tolerance :includes set up tolerance, line regulation and load regulation.</li> <li>Derating may be needed under low input voltages. Please check the derating curve for more details.</li> <li>The ambient temperature derating of 3.5°C/1000m with fanless models and of 5°C/1000m with fan models for operating altitude higher than 2000m(6500ft)</li> <li>The power supply is considered a component which will be installed into a final equipment. The final equipment must be re-confirmed that it still meets EMC directives. For guidance on how to perform these EMC tests, please refer to "EMI testing of component power supplies." (as available on <a href="http://www.meanwell.com">http://www.meanwell.com</a>)</li> <li>Only for Blank type, R type efficiency slightly less than the Blank type.</li> <li>Inrush current parameter has 10% tolerance.</li> </ol> <p>※ Product Liability Disclaimer : For detailed information, please refer to <a href="https://www.meanwell.com/serviceDisclaimer.aspx">https://www.meanwell.com/serviceDisclaimer.aspx</a></p>										

### Block Diagram

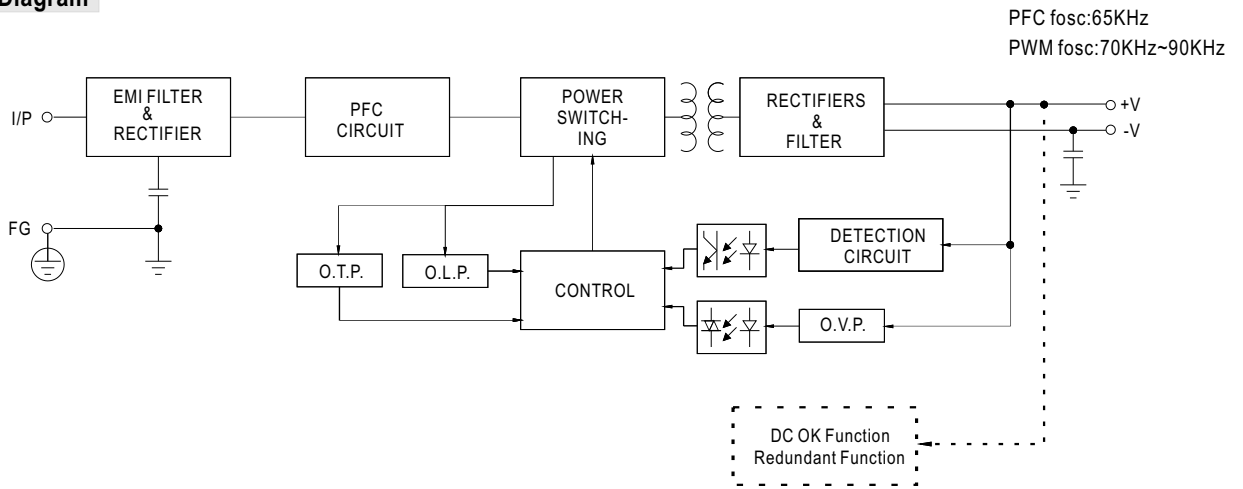

### Derating Curve

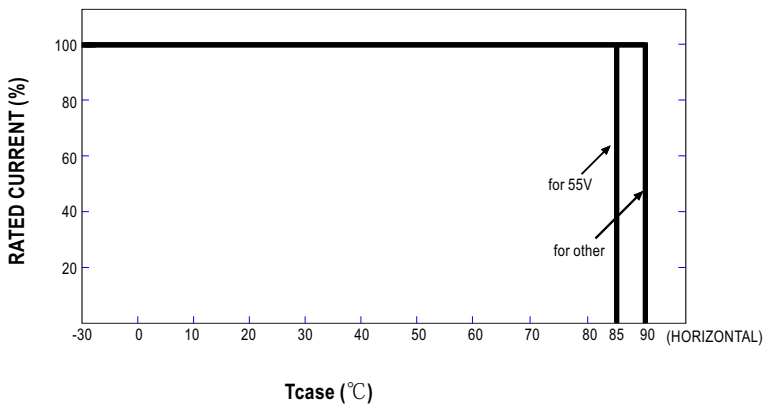
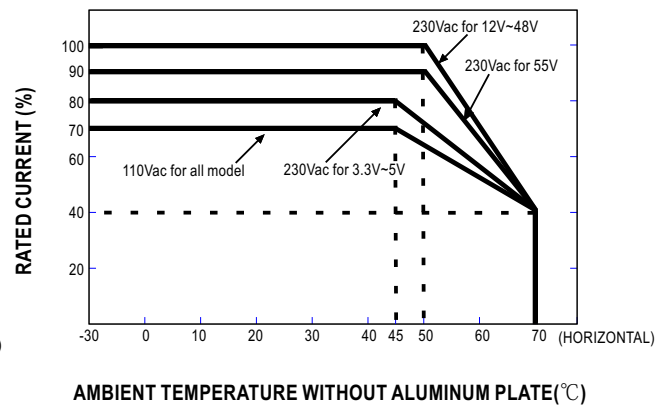
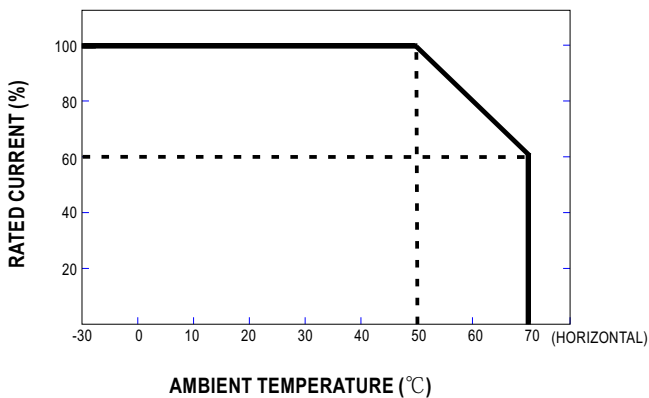

## ■ STATIC CHARACTERISTIC

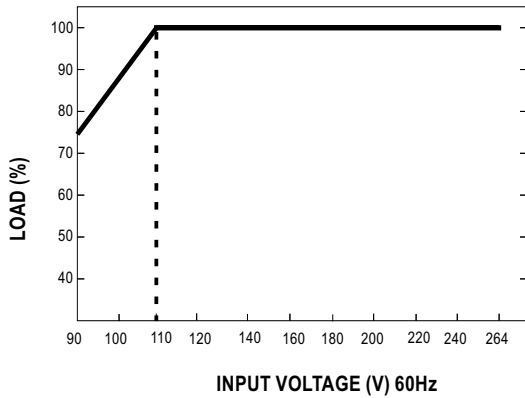

## ■ Function Manual

### 1. DC\_OK Signal

DC\_OK is a collector shorted signal. It is used by an optocoupler in the power supply which indicates the output status of the power supply as exhibited below.

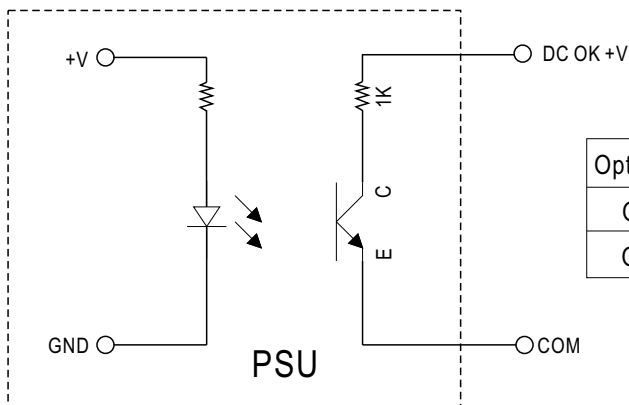

Optocoupler C-E Pin Conduction	PSU turns on	DC ok
Optocoupler C-E Pin Open	PSU turns off	DC fail
Optocoupler Rating(max.)	15Vdc/10mA resistive load	

### 2. Redundant function

- (1) UHP-350R is built-in redundant function and can be connected 2 units in parallel .
- (2) When in parallel operation the maximum load should not be greater than the rated power of any PSU.

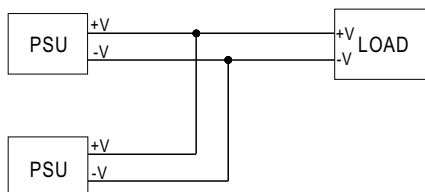

■ Mechanical Specification

CASE NO.:232C

Unit:mm

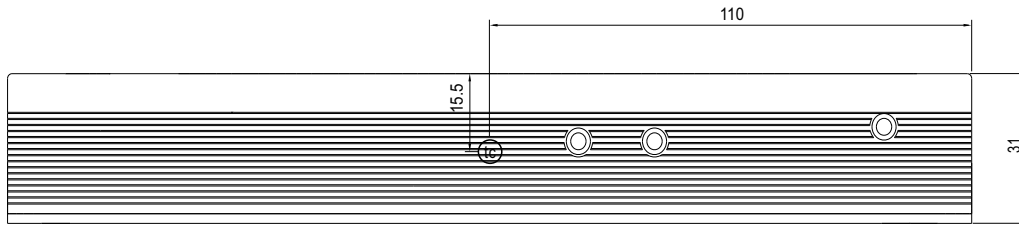
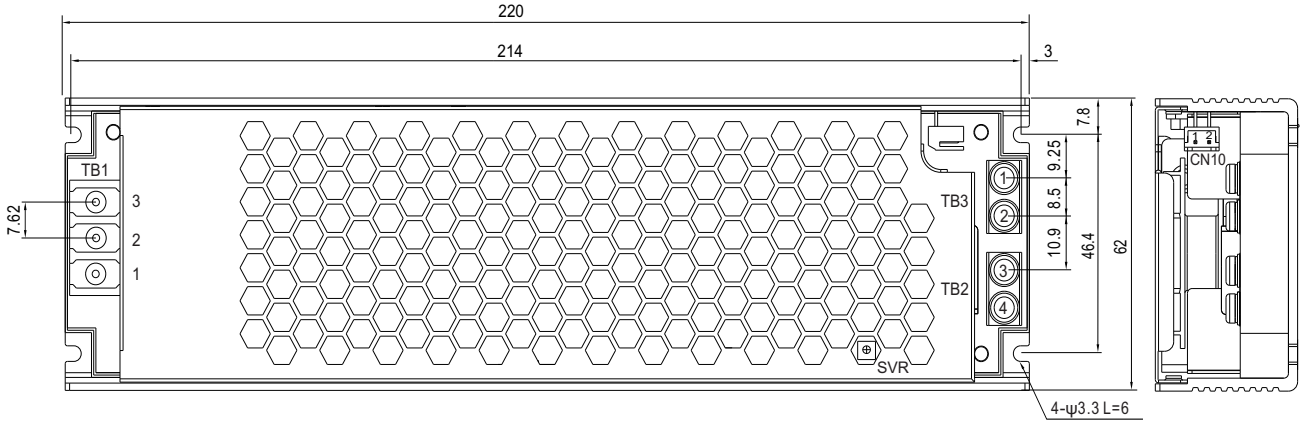

⊙: Max. Case Temperature

AC Input Terminal(TB1) pin NO. Assignment

Pin No.	Assignment	Terminal	Max mounting torque
1	AC/L	(DEGSON) DG28C-B-03P	5Kgf-cm
2	AC/N		
3	⊥		

DC Output Terminal(TB2, TB3) pin NO. Assignment

Pin No.	Assignment	Terminal	Max mounting torque
1,2	-V	(MW)	8Kgf-cm
3,4	+V	TB-HTP-200-40A	

DC OK Connector(CN10):JST B2B-PH-K-S or requivalent

Pin No.	Assignment	Mating Housing	Terminal
1	DC COM	JST PHR-2 or requivalent	JST SPH-002T-P0.5S or requivalent
2	DC OK +V		

**■ Installation****1. Operate with additional aluminum plate**

In order to meet the "Derating Curve" and the "Static Characteristics", UHP-350 series must be installed onto an aluminum plate (or the cabinet of the same size) on the bottom. The size of the suggested aluminum plate is shown as below. And for optimizing thermal performance, the aluminum plate must have an even and smooth surface (or coated with thermal grease), and UHP-350 series must be firmly mounted at the center of the aluminum plate.

unit:mm

