

CIPOS™ Maxi IM818

IM818-MCC

Description

The CIPOS™ Maxi IM818 product group offers the chance for integrating various power and control components to increase reliability, optimize PCB size and system costs. It is designed to control three phase AC motors and permanent magnet motors in variable speed drives applications such as low power motor drives (GPI, Servo drives), pumps, fan drives and active filter for HVAC(Heating, Ventilation, and Air Conditioning). The product concept is specially adapted to power applications, which need good thermal performance and electrical isolation as well as EMI save control and overload protection. Three phase inverter with 1200V TRENCHSTOP™ IGBTs and Emitter Controlled diodes are combined with an optimized 6-channel SOI gate driver for excellent electrical performance.

Features

- Fully isolated Dual In-Line molded module
- 1200V TRENCHSTOP™ IGBT4
- Rugged 1200V SOI gate driver technology with stability against transient and negative voltage
- Allowable negative VS potential up to -11 V for signal transmission at VBS = 15 V
- Integrated bootstrap functionality
- Over current shutdown
- Built-in NTC thermistor for temperature monitor
- Under-voltage lockout at all channels
- Low side emitter pins accessible for all phase current monitoring (open emitter)
- Cross-conduction prevention
- All of 6 switches turn off during protection
- Programmable fault clear timing and enable input
- Lead-free terminal plating; RoHS compliant

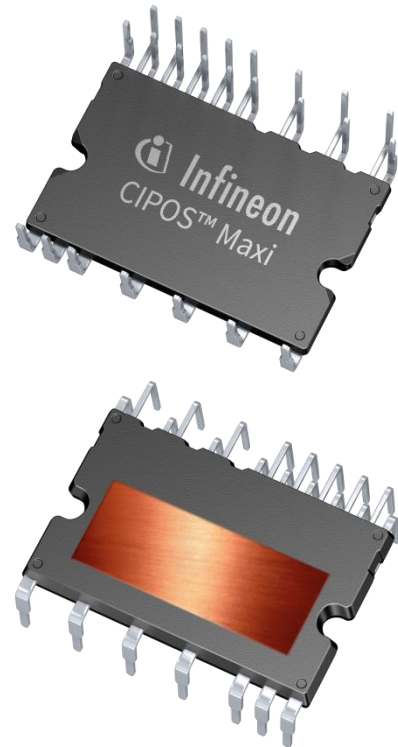

Potential applications

Fan drives and active filter for HVAC, pumps, and low power motor drives (GPI, Servo Drives)

Product validation

Qualified for industrial applications according to the relevant tests of JEDEC47/20/22.

Table 1 Product Information

Product Name	Package Type	Standard Pack		Remark
		Form	MOQ	
IM818-MCC	DIP 36x23D	14 pcs / tube	280	

Table of Contents

Description 1

Features 1

Potential applications 1

Product validation 1

Table of Contents 2

1 Internal Electrical Schematic 3

2 Pin Configuration 4

2.1 Pin Assignment 4

2.2 Pin Description 5

3 Absolute Maximum Ratings 7

3.1 Module Section 7

3.2 Inverter Section 7

3.3 Control Section 7

4 Thermal Characteristics 8

5 Recommended Operation Conditions 9

6 Static Parameters 10

6.1 Inverter Section 10

6.2 Control Section 10

7 Dynamic Parameters 11

7.1 Inverter Section 11

7.2 Control Section 11

8 Thermistor Characteristics 12

9 Mechanical Characteristics and Ratings 13

10 Qualification Information 14

11 Diagrams and Tables 15

11.1 T_c Measurement Point 15

11.2 Backside Curvature Measurement Point 15

11.3 Switching Time Definition 16

12 Application Guide 17

12.1 Typical Application Schematic 17

12.2 Performance Charts 18

13 Package Outline 19

Revision history 20

Internal Electrical Schematic

1 Internal Electrical Schematic

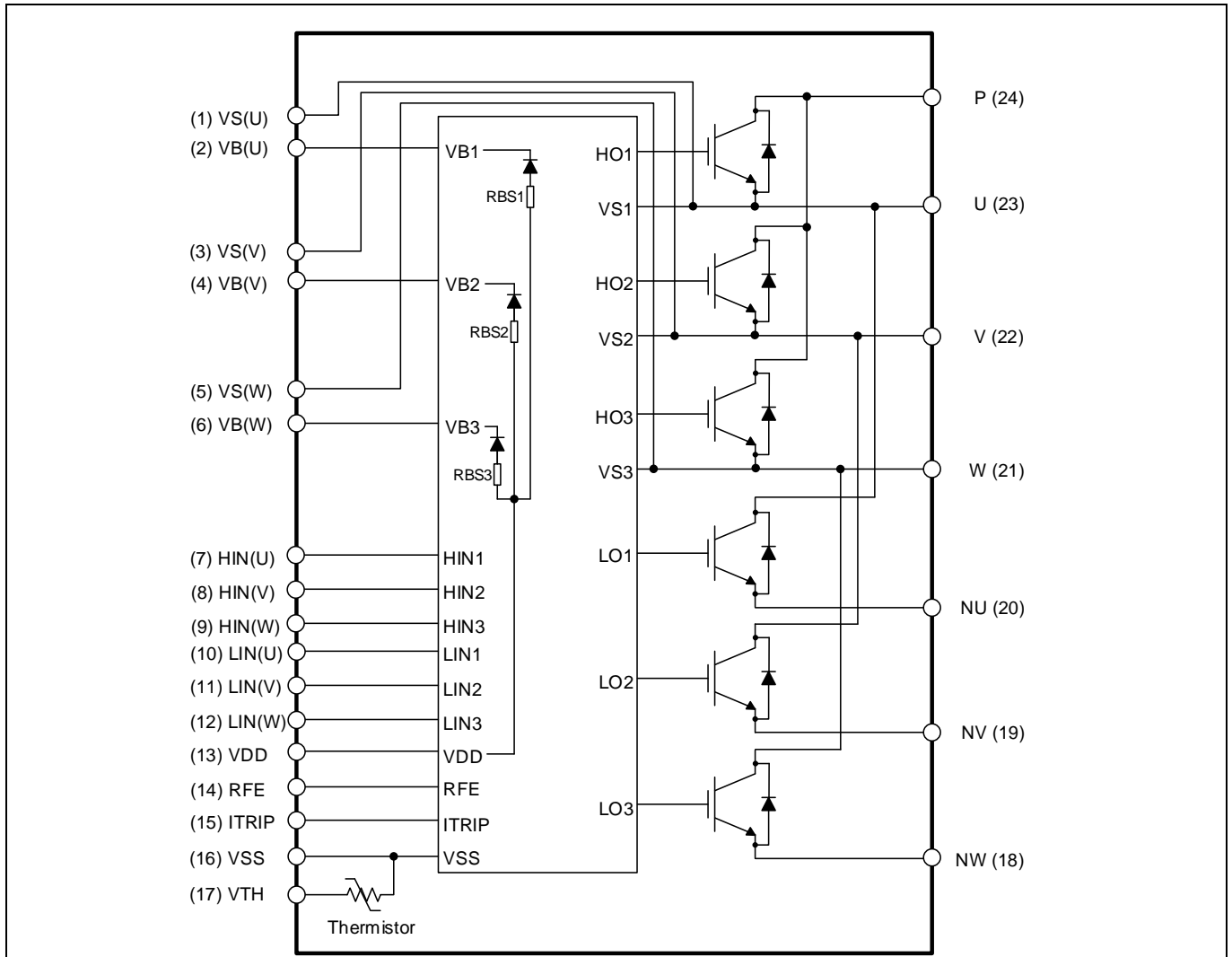

Figure 1 Internal electrical schematic

Pin Configuration

2 Pin Configuration

2.1 Pin Assignment

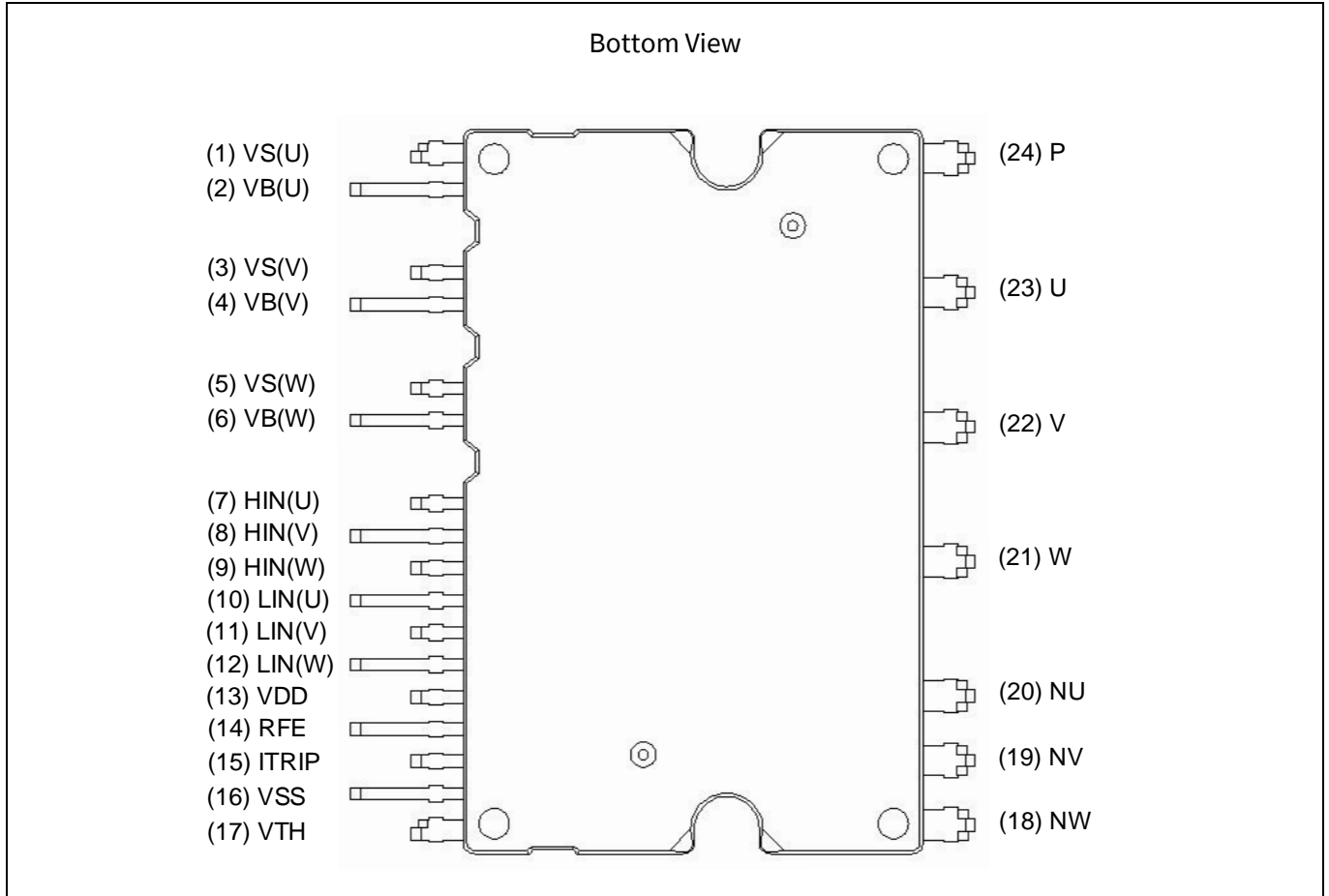

Figure 2 Module pinout

Table 2 Pin Assignment

Pin Number	Pin name	Pin Description
1	VS(U)	U-phase high side floating IC supply offset voltage
2	VB(U)	U-phase high side floating IC supply voltage
3	VS(V)	V-phase high side floating IC supply offset voltage
4	VB(V)	V-phase high side floating IC supply voltage
5	VS(W)	W-phase high side floating IC supply offset voltage
6	VB(W)	W-phase high side floating IC supply voltage
7	HIN(U)	U-phase high side gate driver input
8	HIN(V)	V-phase high side gate driver input
9	HIN(W)	W-phase high side gate driver input
10	LIN(U)	U-phase low side gate driver input
11	LIN(V)	V-phase low side gate driver input
12	LIN(W)	W-phase low side gate driver input
13	VDD	Low side control supply

Pin Configuration

Pin Number	Pin name	Pin Description
14	RFE	Programmable fault clear time, fault output, enable input
15	ITRIP	Over current shutdown input
16	VSS	Low side control negative supply
17	VTH	Thermistor
18	NW	W-phase low side emitter
19	NV	V-phase low side emitter
20	NU	U-phase low side emitter
21	W	Motor W-phase output
22	V	Motor V-phase output
23	U	Motor U-phase output
24	P	Positive bus input voltage

2.2 Pin Description

HIN(U, V, W) and LIN(U, V, W) (Low side and high side control pins, Pin 7 - 12)

These pins are positive logic and they are responsible for the control of the integrated IGBTs. The schmitt-trigger input thresholds of them are such to guarantee LSTTL and CMOS compatibility down to 3.3 V controller outputs. Pull-down resistor of about 5 kΩ is internally provided to pre-bias inputs during supply start-up. Input schmitt-trigger and noise filter provide beneficial noise rejection to short input pulses.

The noise filter suppresses control pulses which are below the filter time $t_{FIL,IN}$. The filter acts according to Figure 4.

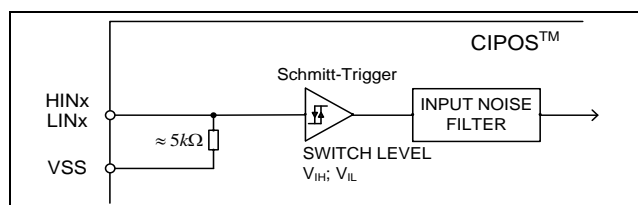

Figure 3 Input pin structure

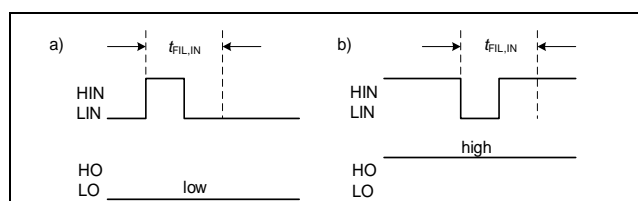

Figure 4 Input filter timing diagram

It is not recommended for proper work to provide input pulse-width lower than 1 μs.

The integrated gate driver provides additionally a shoot through prevention capability which avoids the simultaneous on-state of two gate drivers of the same leg (i.e. HO1 and LO1, HO2 and LO2, HO3 and LO3). When two inputs of a same leg are activated, only former activated one is activated so that the leg is kept steadily in a safe state.

A minimum deadtime insertion of typically 360 ns is also provided by driver IC, in order to reduce cross-conduction of the external power switches.

RFE (Fault / Fault clear time / Enable, Pin 14)

The RFE pin combines three functions in one pin: programmable fault clear time by RC-network, fault-out and enable input.

The programmable fault-clear time can be adjusted by RC network, which is external pull-up resistor and capacitor. For example, typical value is about 1ms at 1 MΩ and 2 nF.

The fault-out indicates a module failure in case of under voltage at pin VDD or in case of triggered over current detection at ITRIP.

The microcontroller can pull this pin low to disable the IPM functionality. This is enable function.

Pin Configuration

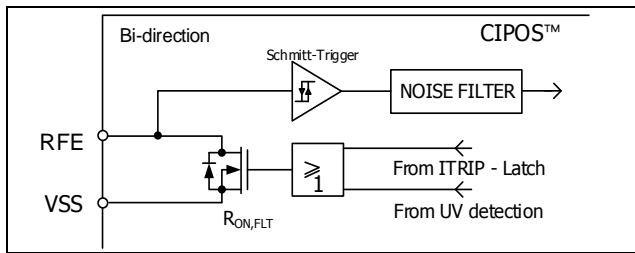

Figure 5 Internal circuit at pin RFE

VTH (Thermistor, Pin 17)

The VTH pin provides direct access to the NTC, which is referenced to VSS. An external pull-up resistor connected to +5 V ensures that the resulting voltage can be directly connected to the microcontroller.

ITRIP (Over current detection function, Pin 15)

IM818 provides an over current detection function by connecting the ITRIP input with the IGBT collector current feedback. The ITRIP comparator threshold (typ. 0.5 V) is referenced to VSS ground. An input noise filter ($t_{ITRIP} = \text{typ. } 500 \text{ ns}$) prevents the driver to detect false over-current events.

Over current detection generates a shutdown of all outputs of the gate driver after the shutdown propagation delay of typically 1µs.

Fault-clear time is set to typical 1.1ms at $R_{RCIN} = 1 \text{ M}\Omega$ and $C_{RCIN} = 2 \text{ nF}$.

VDD, VSS (Low side control supply and reference, Pin 13, 16)

VDD is the control supply and it provides power both to input logic and to output power stage. Input logic is referenced to VSS ground.

The under-voltage circuit enables the device to operate at power on when a supply voltage of at least a typical voltage of $V_{DDUV+} = 12.2 \text{ V}$ is present.

The IC shuts down all the gate drivers power outputs, when the VDD supply voltage is below $V_{DDUV-} = 11.2 \text{ V}$. This prevents the external power switches from critically low gate voltage levels during on-state and therefore from excessive power dissipation.

VB(U, V, W) and VS(U, V, W) (High side supplies, Pin 1 - 6)

VB to VS is the high side supply voltage. The high side circuit can float with respect to VSS following the external high side power device emitter voltage.

Due to the low power consumption, the floating driver stage is supplied by integrated bootstrap circuit.

The under-voltage detection operates with a rising supply threshold of typical $V_{BSUV+} = 11.2 \text{ V}$ and a falling threshold of $V_{BSUV-} = 10.2 \text{ V}$.

VS(U, V, W) provide a high robustness against negative voltage in respect of VSS of -50V transiently. This ensures very stable designs even under rough conditions.

NW, NV, NU (Low side emitter, Pin 18 - 20)

The low side emitters are available for current measurements of each phase leg. It is recommended to keep the connection to pin VSS as short as possible in order to avoid unnecessary inductive voltage drops.

W, V, U (High side emitter and low side collector, Pin 21 - 23)

These pins are motor U, V, W input pins.

P (Positive bus input voltage, Pin 24)

The high side IGBTs are connected to the bus voltage. It is noted that the bus voltage does not exceed 900 V.

Absolute Maximum Ratings

3 Absolute Maximum Ratings

($V_{DD} = 15V$ and $T_J = 25^\circ C$, if not stated otherwise)

3.1 Module Section

Description	Symbol	Condition	Value	Unit
Storage temperature range	T_{STG}		-40 ~ 125	°C
Operating case temperature	T_C	Refer to Figure 6	-40 ~ 125	°C
Operating junction temperature	T_J		-40 ~ 150	°C
Isolation test voltage	V_{ISO}	1min, RMS, f = 60Hz	2500	V

3.2 Inverter Section

Description	Symbol	Condition	Value	Unit
Max. blocking voltage	V_{CES}/V_{RRM}		1200	V
DC link supply voltage of P-N	V_{PN}	Applied between P-N	900	V
DC link supply voltage (surge) of P-N	$V_{PN(surge)}$	Applied between P-N	1000	V
DC collector current	I_C	$T_C = 25^\circ C, T_J < 150^\circ C$	±16	A
		$T_C = 80^\circ C, T_J < 150^\circ C$	±10	
Peak collector current	I_{CP}	$T_C = 25^\circ C, t_p < 1 \text{ ms}$	±20	A
Power dissipation per IGBT	P_{tot}		67.5	W
Short circuit withstand time ¹	t_{SC}	$V_{DC} \leq 800 \text{ V}, T_J = 150^\circ C$	10	µs

3.3 Control Section

Description	Symbol	Condition	Value	Unit
High Side offset voltage	V_S		1200	V
Repetitive peak reverse voltage of bootstrap diode	V_{RRM}		1200	V
Module control supply voltage	V_{DD}		-1 ~ 20	V
High side floating supply voltage (V_B reference to V_S)	V_{BS}		-1 ~ 20	V
Input voltage(LIN, HIN, ITRIP, RFE)	V_{IN}		-1 ~ $V_{DD} + 0.3$	V

¹ Allowed number of short circuits: < 1000; Time between short circuits: > 1 s.

4 Thermal Characteristics

Description	Symbol	Condition	Value			Unit
			Min.	Typ.	Max.	
Single IGBT thermal resistance, junction-case	R_{thJC}	High side V-phase IGBT	-	-	1.85	K/W
Single diode thermal resistance, junction-case	$R_{thJC,D}$	High side V-phase diode	-	-	2.50	K/W

Recommended Operation Conditions

5 Recommended Operation Conditions

All voltages are absolute voltages referenced to V_{SS} -potential unless otherwise specified.

Description	Symbol	Value			Unit
		Min.	Typ.	Max.	
DC link supply voltage of P-N	V_{PN}	350	600	800	V
Low side supply voltage	V_{DD}	13.5	15	18.5	V
High side floating supply voltage (V_B vs. V_S)	V_{BS}	12.5	-	18.5	V
Logic input voltages LIN, HIN, ITRIP, RFE	V_{IN}	0	-	5	V
PWM carrier frequency	F_{PWM}	-	-	20	kHz
External dead time between HIN & LIN	DT	0.5	-	-	μ s
Voltage between VSS - N (including surge)	V_{COMP}	-5	-	5	V
Minimum input pulse width	$PW_{IN(ON)}$	1	-	-	μ s
	$PW_{IN(OFF)}$				
Control supply variation	$\Delta V_{BS,}$	-1	-	1	V/ μ s
	ΔV_{DD}	-1	-	1	

6 Static Parameters

($V_{DD} = 15V$ and $T_J = 25^\circ C$, if not stated otherwise)

6.1 Inverter Section

Description	Symbol	Condition	Value			Unit
			Min.	Typ.	Max.	
Collector-Emitter saturation voltage	$V_{CE(sat)}$	$I_C = 10 A$ $T_J = 25^\circ C$ $150^\circ C$	- -	2.0 2.6	2.4 -	V
Collector-Emitter leakage current	I_{CES}	$V_{CE} = 1200 V$	-	-	1	mA
Diode forward voltage	V_F	$I_F = 10 A$ $T_J = 25^\circ C$ $150^\circ C$	- -	1.75 1.75	2.25 -	V

6.2 Control Section

Description	Symbol	Condition	Value			Unit
			Min.	Typ.	Max.	
Logic "1" input voltage (LIN, HIN)	V_{IH}		-	1.9	2.3	V
Logic "0" input voltage (LIN, HIN)	V_{IL}		0.7	0.9	-	V
ITRIP positive going threshold	$V_{IT,TH+}$		475	500	525	mV
ITRIP input hysteresis	$V_{IT,HYS}$		-	55	-	mV
V_{DD} and V_{BS} supply under voltage positive going threshold	V_{DDUV+} V_{BSUV+}		11.5 10.5	12.2 11.2	13.0 12.0	V
V_{DD} / V_{BS} supply under voltage negative going threshold	V_{DDUV-} V_{BSUV-}		10.5 9.5	11.2 10.2	12.0 11.0	V
V_{DD} / V_{BS} supply under voltage lockout hysteresis	V_{DDUVH} V_{BSUVH}		-	1	-	V
Quiescent V_{Bx} supply current (V_{Bx} only)	I_{QBS}	$H_{IN} = 0 V$	-	175	-	μA
Quiescent V_{DD} supply current (V_{DD} only)	I_{QDD}	$L_{IN} = 0 V, H_{INX} = 5 V$	-	1	-	mA
Input bias current for LIN, HIN	I_{IN+}	$V_{IN} = 5 V$	-	1	-	mA
Input bias current for ITRIP	I_{ITRIP+}	$V_{ITRIP} = 5 V$	-	30	100	μA
Input bias current for RFE	I_{RFE}	$V_{RFE} = 5 V,$ $V_{ITRIP} = 0 V$	-	-	5	μA
RFE output voltage	V_{RFE}	$I_{RFE} = 10 mA,$ $V_{ITRIP} = 1 V$	-	0.4	-	V
V_{RFE} positive going threshold	$V_{RFE,TH+}$		-	1.9	2.3	V
V_{RFE} negative going threshold	$V_{RFE,TH-}$		0.7	0.9	-	V
Bootstrap diode forward voltage	V_{F_BSD}	$I_F = 0.3 mA$	-	0.9	-	V
Bootstrap diode resistance	R_{BSD}	Between $V_F = 4 V$ and $V_F = 5 V$	-	120	-	Ω

Dynamic Parameters

7 Dynamic Parameters

($V_{DD} = 15V$ and $T_J = 25^\circ C$, if not stated otherwise)

7.1 Inverter Section

Description	Symbol	Condition	Value			Unit
			Min.	Typ.	Max.	
Turn-on propagation delay time	t_{on}	$V_{LIN, HIN} = 5 V,$ $I_C = 10 A,$ $V_{DC} = 600 V$	-	800	-	ns
Turn-on rise time	t_r		-	45	-	ns
Turn-on switching time	$t_{c(on)}$		-	230	-	ns
Reverse recovery time	t_{rr}		-	420	-	ns
Turn-off propagation delay time	t_{off}	$V_{LIN, HIN} = 0 V,$ $I_C = 10 A,$ $V_{DC} = 600 V$	-	960	-	ns
Turn-off fall time	t_f		-	100	-	ns
Turn-off switching time	$t_{c(off)}$		-	200	-	ns
Short circuit propagation delay time	t_{SCP}	From $V_{IT, TH+}$ to 10% I_{SC}	-	1200	-	ns
IGBT turn-on energy (includes reverse recovery of diode)	E_{on}	$V_{DC} = 600 V,$ $I_C = 10 A$ $T_J = 25^\circ C$ $150^\circ C$	-	1.1	-	mJ
			-	1.6	-	
IGBT turn-off energy	E_{off}	$V_{DC} = 600 V,$ $I_C = 10 A$ $T_J = 25^\circ C$ $150^\circ C$	-	0.6	-	mJ
			-	0.9	-	
Diode recovery energy	E_{rec}	$V_{DC} = 600 V,$ $I_C = 10 A$ $T_J = 25^\circ C$ $150^\circ C$	-	0.3	-	mJ
			-	0.6	-	

7.2 Control Section

Description	Symbol	Condition	Value			Unit
			Min.	Typ.	Max.	
Input filter time ITRIP	t_{ITRIP}	$V_{ITRIP} = 1 V$	-	500	-	ns
Input filter time at LIN, HIN for turn on and off	$t_{FIL, IN}$	$V_{LIN, HIN} = 0 V$ or $5 V$	-	350	-	ns
Fault clear time after ITRIP-fault	$t_{FLT, CLR}$	$V_{ITRIP} = 1V,$ $V_{pull-up} = 5V$ ($R = 1 M\Omega, C = 2 nF$)		1.1	-	ms
ITRIP to Fault propagation delay	t_{FLT}	$V_{LIN, HIN} = 0$ or $5 V,$ $V_{ITRIP} = 1V$	-	650	900	ns
Internal deadtime	DT_{IC}	$V_{IN} = 0$ or $V_{IN} = 5 V$	300	-	-	ns
Matching propagation delay time (On & Off) all channels	M_T	External dead time > 500ns	-	-	130	ns

8 Thermistor Characteristics

Description	Condition	Symbol	Value			Unit
			Min.	Typ.	Max.	
Resistor	$T_{NTC} = 25^{\circ}\text{C}$	R_{NTC}	-	85	-	$\text{k}\Omega$
B-constant of NTC (Negative Temperature Coefficient)		$B(25/100)$	-	4092	-	K

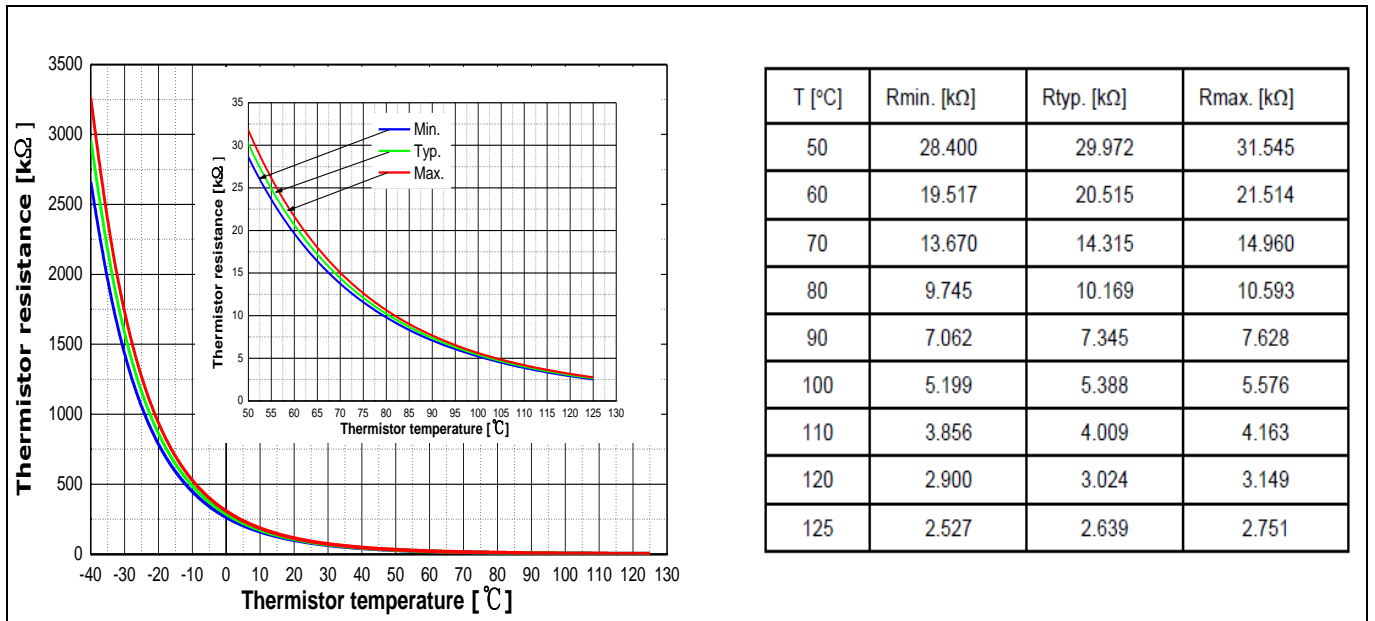

Figure 6 Thermistor resistance – temperature curve and table

(For more information, please refer to the application note ‘AN2019-16 CIPOS™ Maxi IM818 application note’)

9 Mechanical Characteristics and Ratings

Description	Condition	Value			Unit
		Min.	Typ.	Max.	
Comparative Tracking Index(CTI)		600	-	-	
Mounting torque	M3 screw and washer	0.49	-	0.78	Nm
Backside Curvature	Refer to Figure 8	0	-	150	μm
Weight		-	7.1	-	g

Qualification Information

10 Qualification Information

UL Certification	File number E314539	
Moisture sensitivity level (SOP package only)	-	
RoHS Compliant	Yes (Lead-free terminal plating)	
ESD(Electrostatic Discharge)	HBM(Human body model) Class as per JESD22-A114	2 (>2000V to < 4000V)
	CDM(Charged Device model) Class as per JESD22-C101	C3 (>=1000V)

Diagrams and Tables

11 Diagrams and Tables

11.1 T_c Measurement Point

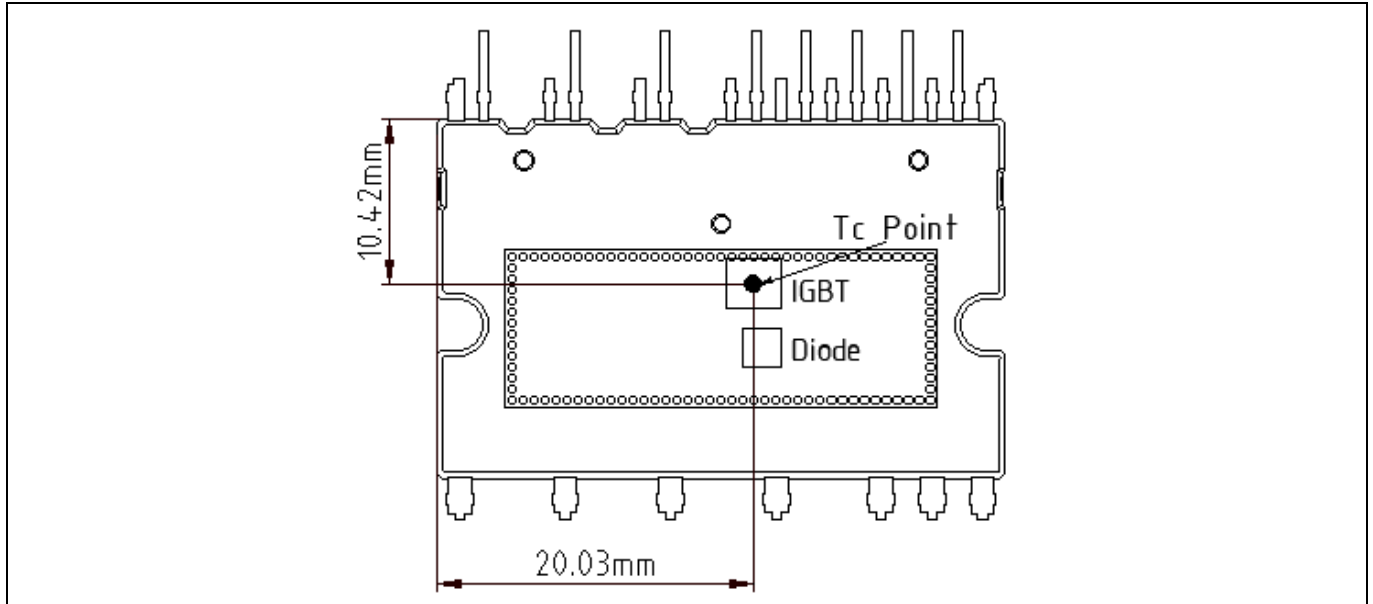

Figure 7 T_c measurement point¹

11.2 Backside Curvature Measurement Point

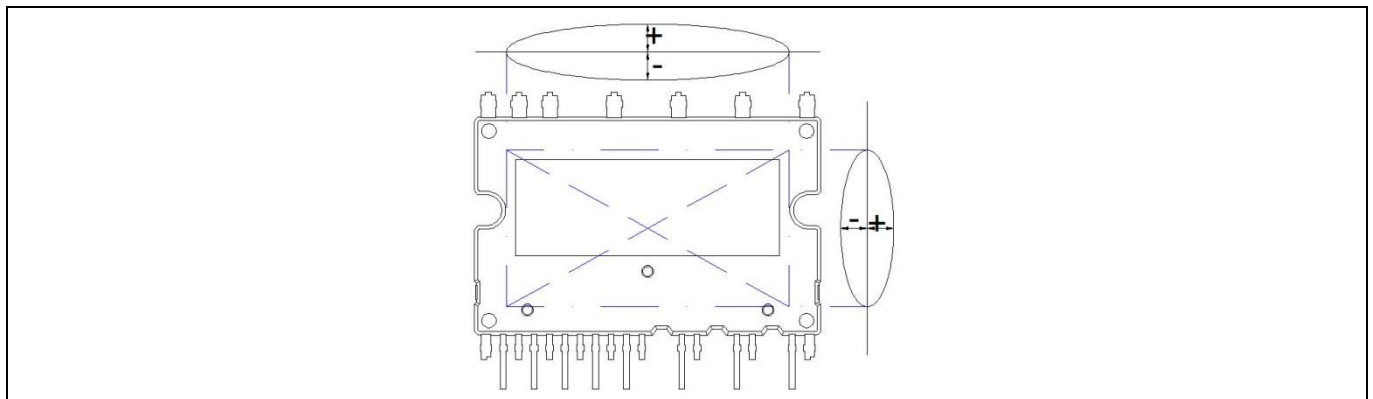

Figure 8 Backside curvature measurement position

¹Any measurement except for the specified point in Figure 7 is not relevant for the temperature verification and brings wrong or different information.

Diagrams and Tables

11.3 Switching Time Definition

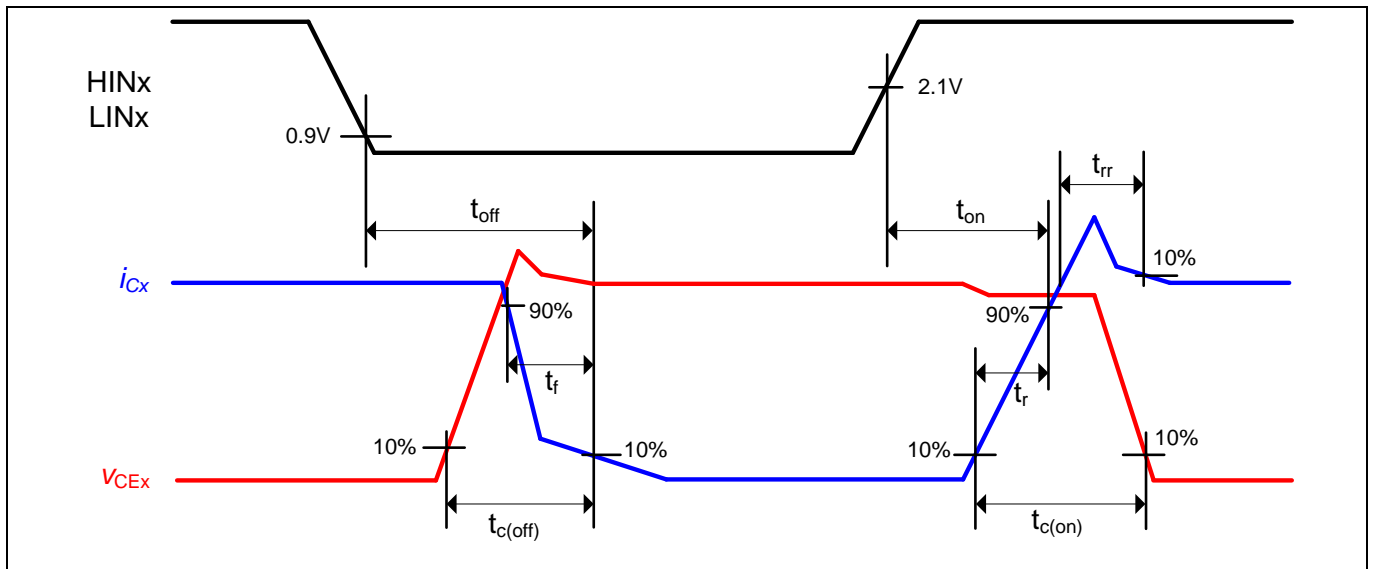

Figure 9 Switching times definition

12 Application Guide

12.1 Typical Application Schematic

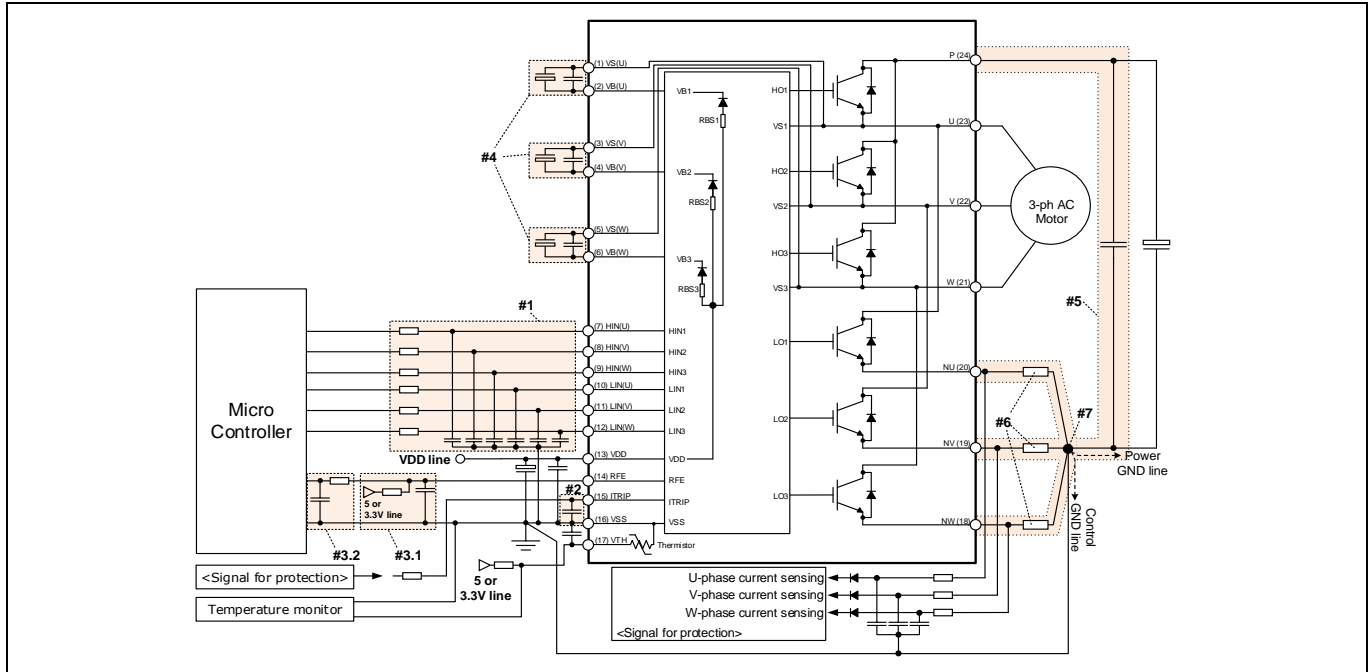

Figure 10 Typical application circuit

1. Input circuit
 - To reduce input signal noise by high speed switching, the R_{IN} and C_{IN} filter circuit should be mounted. (100 Ω , 1 nF)
 - C_{IN} should be placed as close to V_{SS} pin as possible.
2. Itrip circuit
 - To prevent protection function errors, C_{ITRIP} should be placed as close to Itrip and V_{SS} pins as possible.
3. RFE circuit
 - 3.1 Pull-up resistor and pull-down capacitor
 - RFE output is an open drain output. This signal line should be pulled up to the positive side of the 5 V / 3.3 V logic power supply with a proper resistor R_{PU} .
 - The fault-clear time is adjusted by RC network of a pull-up resistor, a pull-down capacitor and pull-up voltage.
 - $t_{FLTCLR} = -R_{pull-up} \cdot C_{pull-down} \cdot \ln(1 - V_{RFE,TH+}/V_{pull-up}) + \text{internal fault-clear time } 160 \mu s$
 - $t_{FLTCLR} = -1 \text{ M}\Omega \times 2 \text{ nF} \times \ln(1 - 1.9 / 5 \text{ V}) + 160 \mu s \cong 1.1 \text{ ms}$ at $R = 1 \text{ M}\Omega$, $C = 2 \text{ nF}$ and $V_{pull-up} = 5 \text{ V}$
 - A pull-up resistor is limited to max. 2 M Ω
 - 3.2 RC filter
 - It is recommended that RC filter be placed as close to the controller as possible.
4. VB-VS circuit
 - Capacitor for high side floating supply voltage should be placed as close to VB and VS pins as possible.
5. Snubber capacitor
 - The wiring between IM818 and snubber capacitor including shunt resistor should be as short as possible.
6. Shunt resistor
 - The shunt resistor of SMD type should be used for reducing its stray inductance.
7. Ground pattern
 - Ground pattern should be separated at only one point of shunt resistor as short as possible.

12.2 Performance Charts

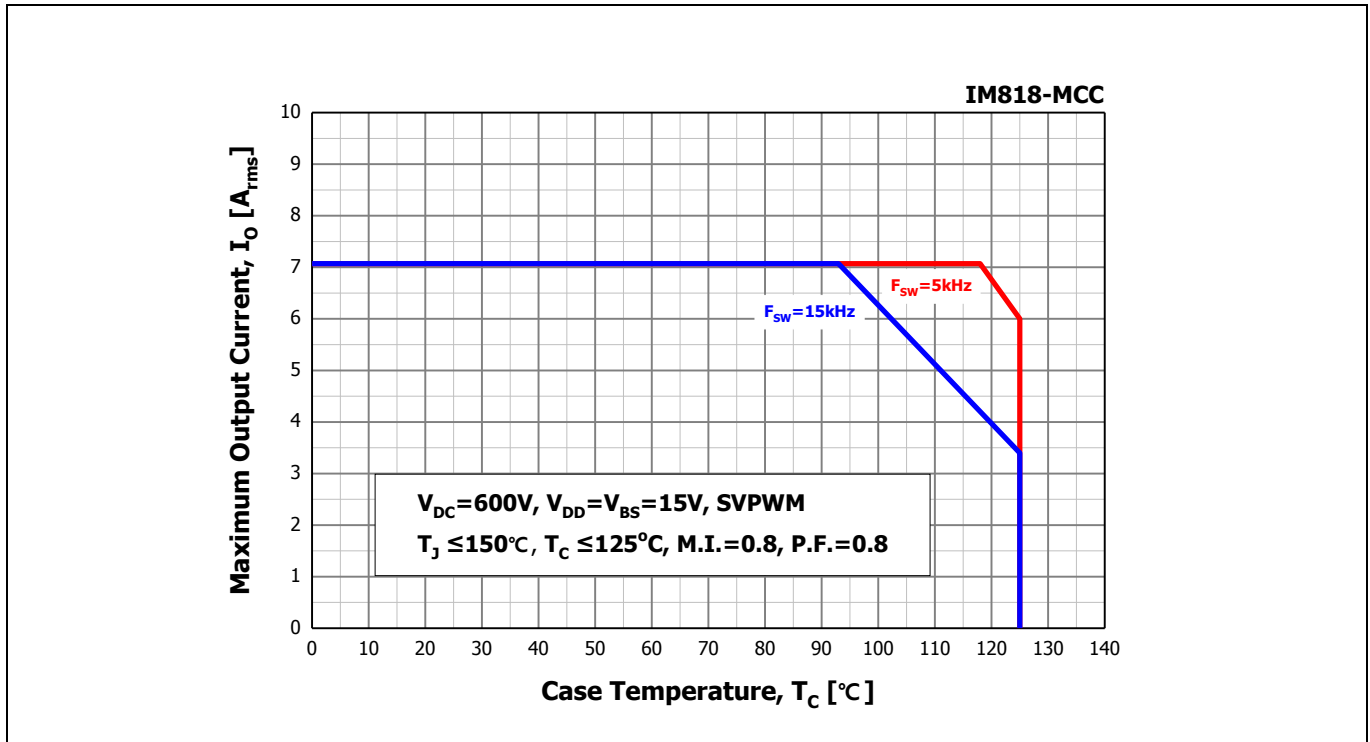
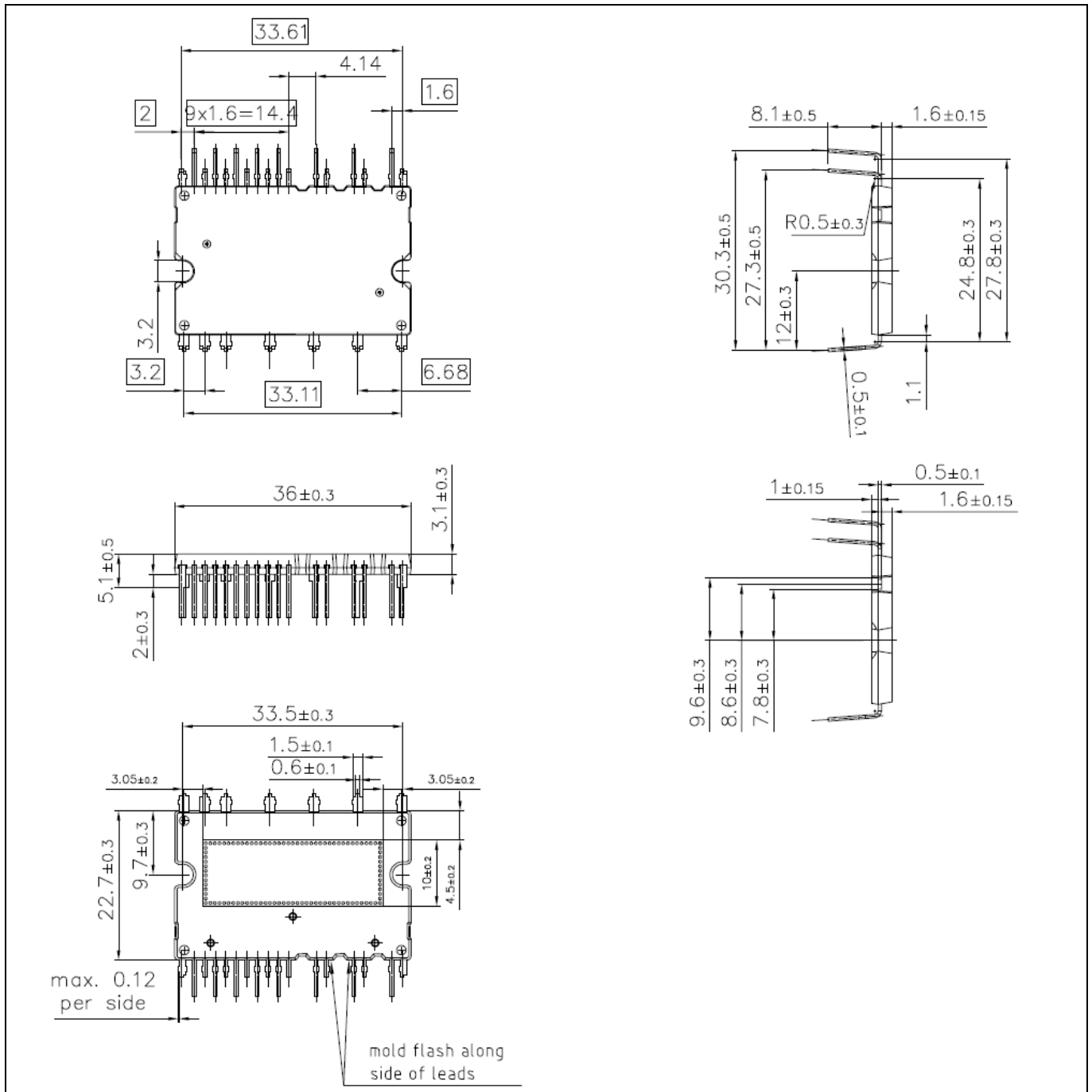

Figure 11 Maximum operating current SOA¹

¹This maximum operating current SOA is just one of example based on typical characteristics for this product. It can be changed by each user's actual operating conditions.

Package Outline

13 Package Outline



Revision history

Document version	Date of release	Description of changes
V2.2	June, 2019	Corrected typo section 7.1(HINx, LINx = 0 V) Minor change – Table 1 and reference document (AN) number in figure 6
V2.1	August, 2018	Minor change - Figure7, section 4(thermal resistance), section 10(qualification information), section 13(package outline)
V2.0	June, 2018	Initial release

Trademarks

All referenced product or service names and trademarks are the property of their respective owners.

Edition 2019-06-07

Published by

Infineon Technologies AG

81726 München, Germany

© 2019 Infineon Technologies AG.

All Rights Reserved.

Do you have a question about this document?

Email: erratum@infineon.com

Document reference

ifx1

IMPORTANT NOTICE

The information given in this document shall in no event be regarded as a guarantee of conditions or characteristics ("Beschaffheitsgarantie").

With respect to any examples, hints or any typical values stated herein and/or any information regarding the application of the product, Infineon Technologies hereby disclaims any and all warranties and liabilities of any kind, including without limitation warranties of non-infringement of intellectual property rights of any third party.

In addition, any information given in this document is subject to customer's compliance with its obligations stated in this document and any applicable legal requirements, norms and standards concerning customer's products and any use of the product of Infineon Technologies in customer's applications.

The data contained in this document is exclusively intended for technically trained staff. It is the responsibility of customer's technical departments to evaluate the suitability of the product for the intended application and the completeness of the product information given in this document with respect to such application.

For further information on the product, technology, delivery terms and conditions and prices please contact your nearest Infineon Technologies office (www.infineon.com).

Please note that this product is not qualified according to the AEC Q100 or AEC Q101 documents of the Automotive Electronics Council.

WARNINGS

Due to technical requirements products may contain dangerous substances. For information on the types in question please contact your nearest Infineon Technologies office.

Except as otherwise explicitly approved by Infineon Technologies in a written document signed by authorized representatives of Infineon Technologies, Infineon Technologies' products may not be used in any applications where a failure of the product or any consequences of the use thereof can reasonably be expected to result in personal injury.