

Automotive & Industrial Grade Ceramic SMD Miniature Crystal



5.0 X 3.2 X 0.9mm

ABM3BAIG

Pb | **RoHS/RoHS II Compliant**

Moisture Sensitivity Level (MSL) – This product is Hermetically Sealed and not Moisture Sensitive - MSL = N/A: Not Applicable

FEATURES:

- AEC-Q200 qualified
- Seam sealed ceramic package assures high precision and reliability
- Extended temperature -40°C to +125°C for automotive/industrial applications
- Suitable for RoHS reflow profile
- 100 times drop test from 150cm, suitable for keyless entry application

APPLICATIONS:

- Automotive electronics
- Industrial electronics

STANDARD SPECIFICATIONS:

Parameters	Minimum	Typical	Maximum	Units	Notes
Frequency Range	12.000		54.000	MHz	
Operation Mode	Fundamental, AT-cut				
Operating Temperature	-40		+125	°C	See options
Storage Temperature	-40		+125	°C	
Frequency Tolerance @+25°C	-50		+50	ppm	See options
Frequency Stability over the Operating Temperature (ref. to +25°C)	-100		+100	ppm	Please contact Abracon for the availability of ±50ppm Frequency stability
Equivalent series resistance (R1)			70	Ω	12.000 – 15.999MHz
			50		16.000 – 54.000MHz
Shunt capacitance (C0)			7	pF	
Load capacitance (CL)		18		pF	Standard (See options if other than STD)
Drive Level		10	100	μW	
Aging	-3		+3	ppm	@25°C±3°C First year
Insulation Resistance	500			MΩ	@ 100Vdc ± 15V

OPTIONS AND PART IDENTIFICATION:

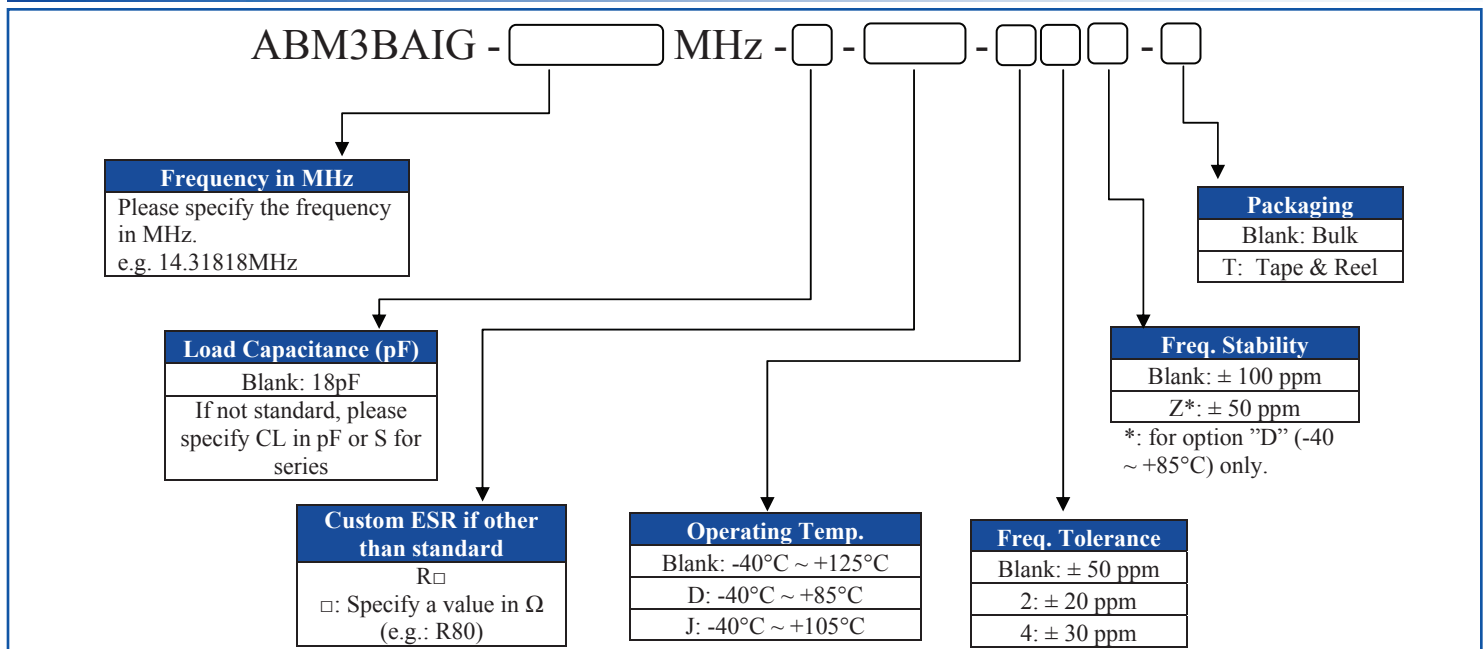

Automotive & Industrial Grade Ceramic SMD Miniature Crystal



5.0 X 3.2 X 0.9mm

ABM3BAIG

Pb | **RoHS/RoHS II Compliant**

OUTLINE DIMENSIONS:

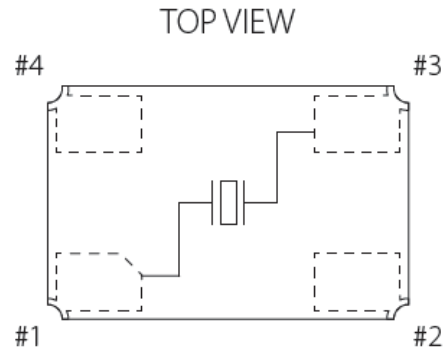
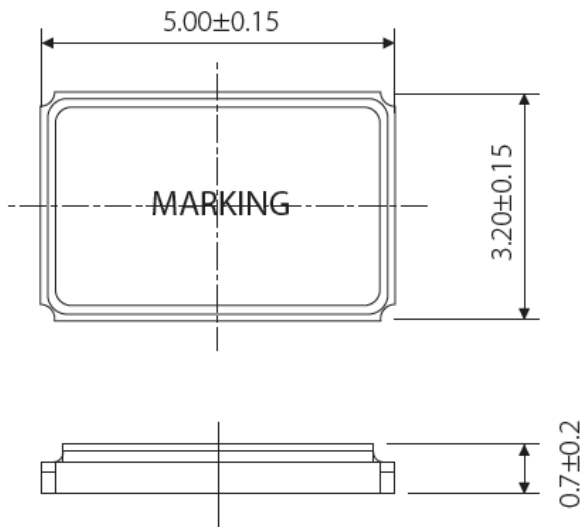

- #1,#3 : Crystal terminal
- #2,#4 : Connected to cover
(Please connect it with GND.)

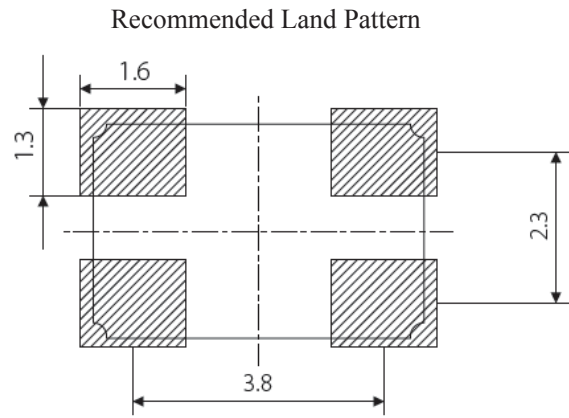
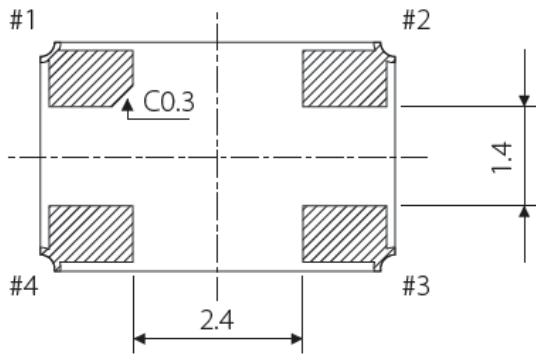

Dimensions: mm

REFLOW PROFILE:

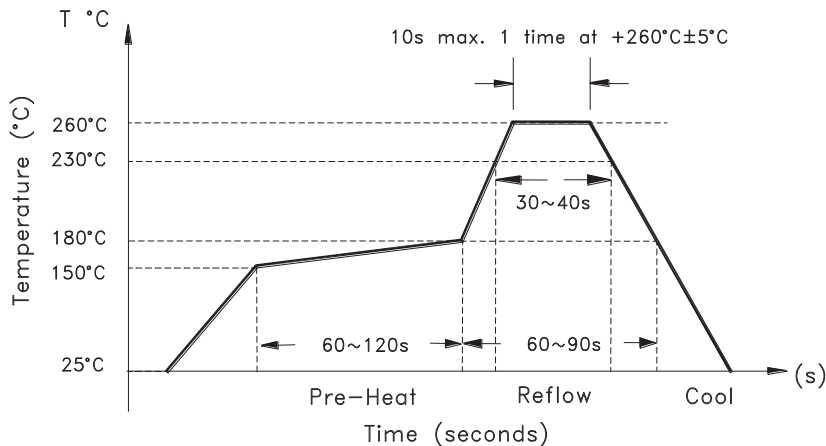



5.0 X 3.2 X 0.9mm

ABM3BAIG

RoHS/RoHS II Compliant

TAPE & REEL:

Packaging: 1000pcs/reel

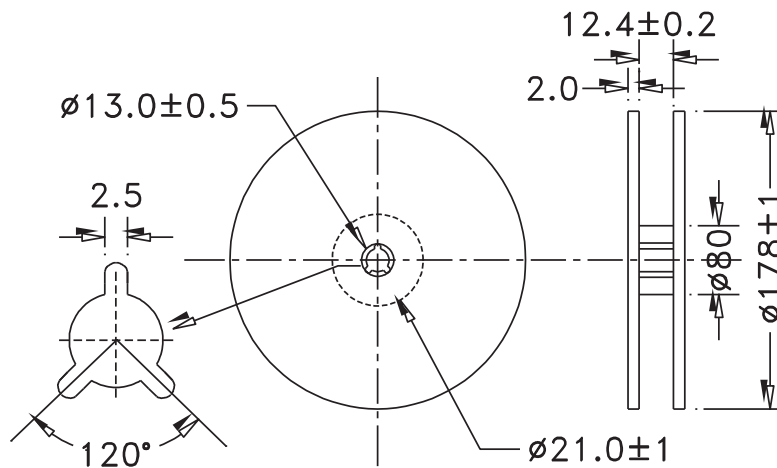
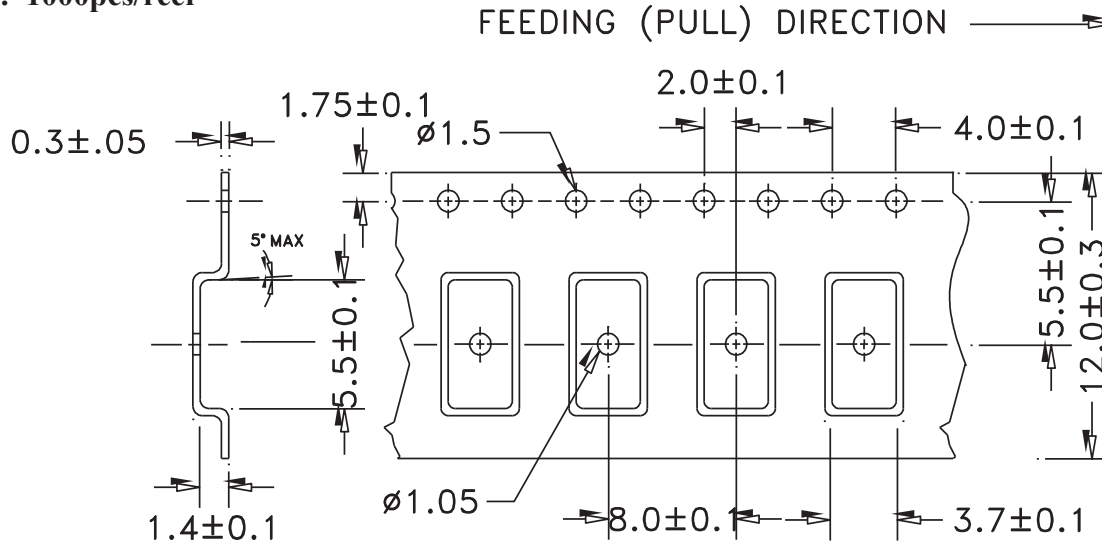

Dimensions: mm

ATTENTION: Abracon Corporation's products are COTS – Commercial-Off-The-Shelf products; suitable for Commercial, Industrial and, where designated, Automotive Applications. Abracon's products are not specifically designed for Military, Aviation, Aerospace, Life-dependant Medical applications or any application requiring high reliability where component failure could result in loss of life and/or property. For applications requiring high reliability and/or presenting an extreme operating environment, written consent and authorization from Abracon Corporation is required. Please contact Abracon Corporation for more information.

Pierce Analyzer System (PAS) Advanced Board Characterization Service

Abracon PAS System enables us to offer Automotive, Medical, and Industrial application customers a comprehensive, automated assessment of the Pierce Oscillator loop, in concert with the customers selected Quartz Crystal. The PAS System Circuit Analysis report is ideally suited for PPAP documentation, design history reporting, and overall assurance of a reliable optimized circuit.

Features:

- Circuit characterization; providing best possible match between Quartz Crystal, oscillator loop and associated components
- Eliminates probability of oscillator start-up issues related to inadequate design or marginal component performance
- Eliminates production launch issues related to crystal oscillator based timing circuit
- Solves design margin uncertainty

Deliverables: A detail Report encompassing:

• **Stand alone Quartz Crystal characteristics including:**

- Motional parameters (Cm, Lm, ESR & C0)
- Narrow Band Frequency Response Plot
- Wide Band Frequency Response Plot
- Admittance versus Susceptance plot
- Frequency dependence versus load capacitance plot

• **Oscillator loop characteristics including:**

- Initial frequency accuracy and drive level as seen by the crystal with measured ESR
- Worst case projected drive level with maximum specified ESR
- Safety Factor of the oscillator loop under both typical and maximum ESR
- Recommendation on proper component selection (C1, C2 & Rs when applicable) for best compromise with respect to Safety Factor and Frequency accuracy
- Recommendation on the Abracon Crystal part # with proper plating load and other key attributes to enable the most robust design, specific to the μ controller/processor implemented

Ordering information:

PAS-BC1WK	Analysis & Report with 1-week maximum lead-time
PAS-BC2WK	Analysis & Report with 2-week maximum lead-time
PAS-BC3WK	Analysis & Report with 3-week maximum lead-time

For detailed information, click here:



For additional information, please contact at: tech-support@abracon.com