

4

3

2

1

THIS DRAWING IS UNPUBLISHED. RELEASED FOR PUBLICATION 20
 © COPYRIGHT 20 BY TYCO ELECTRONICS CORPORATION. ALL RIGHTS RESERVED.

LOC	DIST	REVISIONS			
P	LTR	DESCRIPTION	DATE	DWN	APVD
FT	0	A	RELEASED	24MAY2006	SW SY

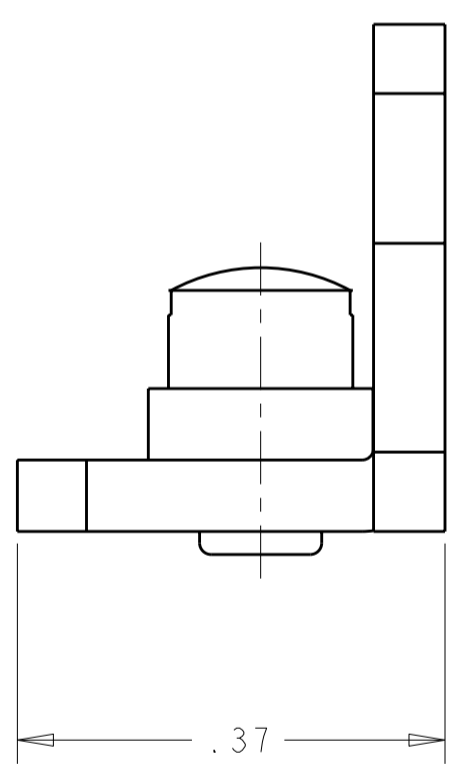
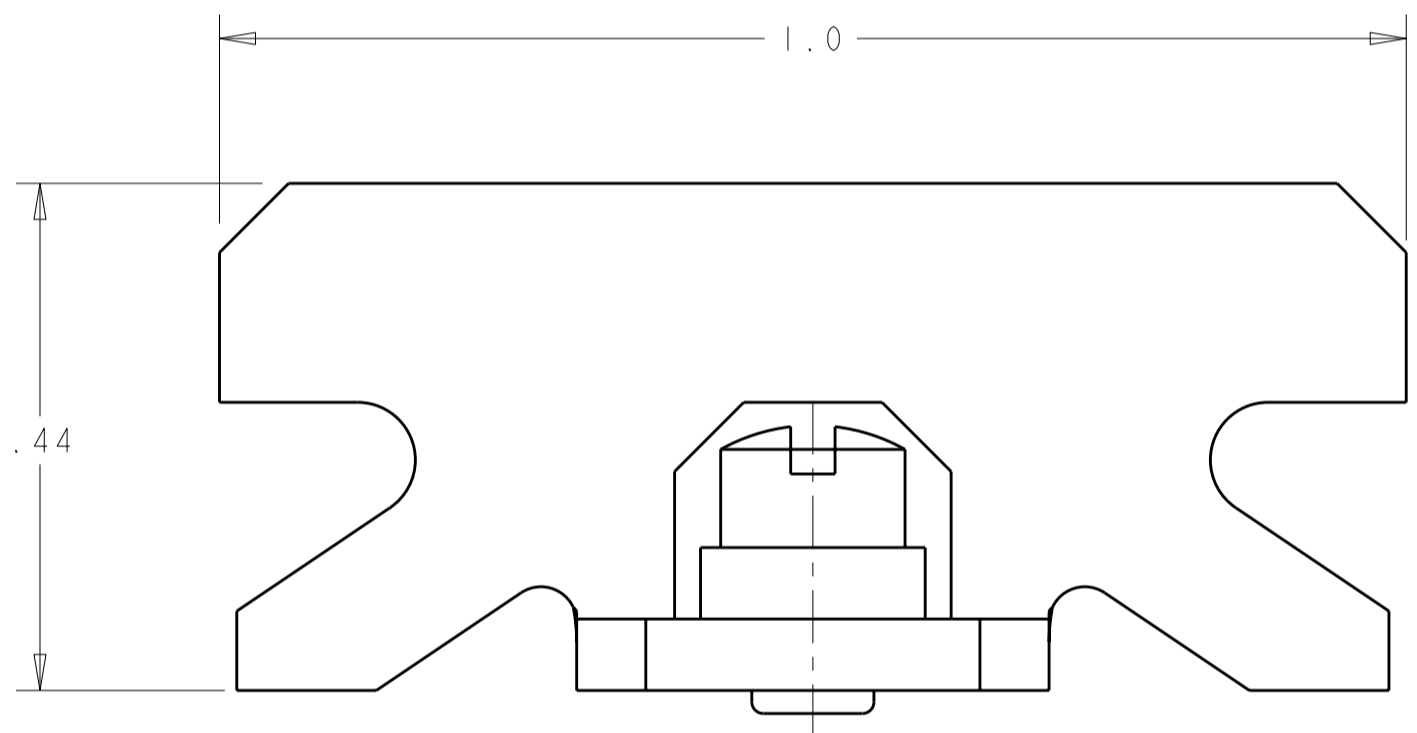
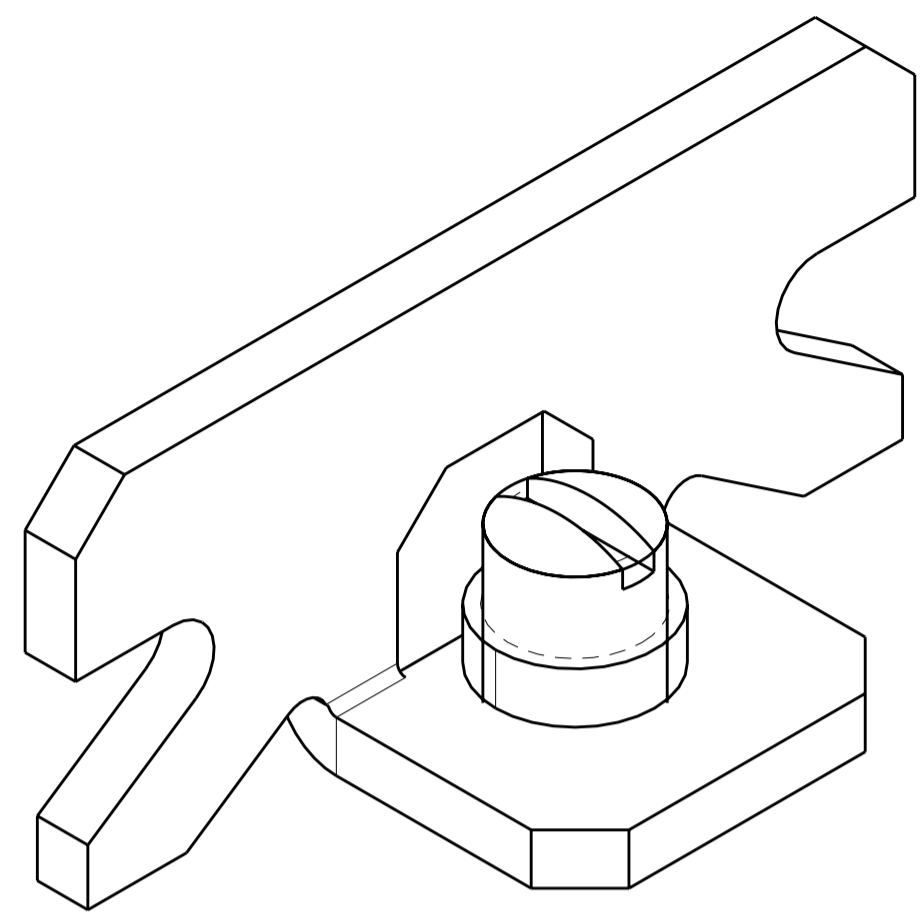
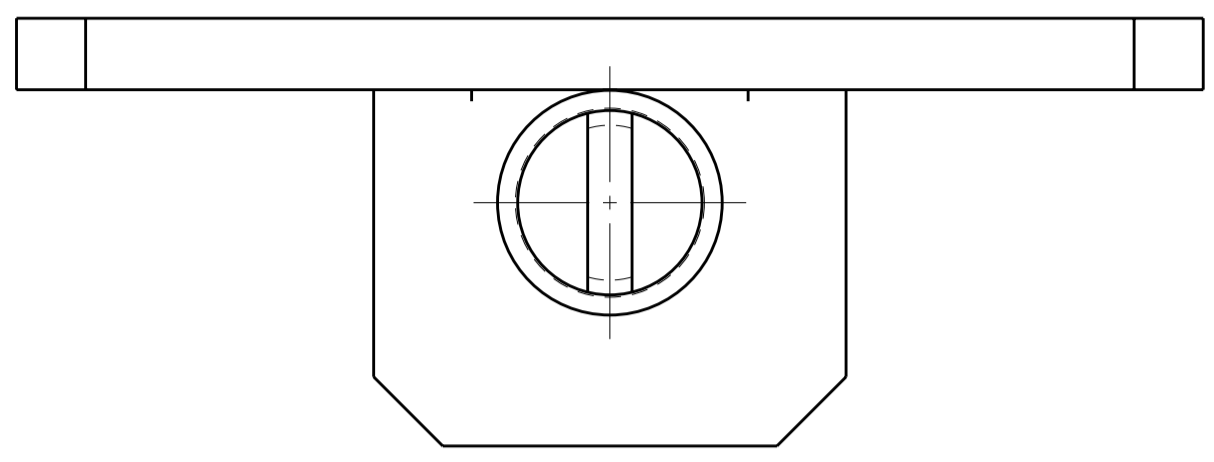

- 1. CHANNEL CLAMP:
 MATERIAL: STEEL
 FINISH: ZINC PLATE CLEAR CHROMATE.
- SET SCREW:
 MATERIAL: STEEL
 FINISH: ZINC PLATE CLEAR CHROMATE.
 THREADS - #8-32
- 2. RUNNING TORQUE: 0-4 IN-LBS

9-1437381-5
 PART NUMBER

<small>THIS DRAWING IS A CONTROLLED DOCUMENT FOR TYCO ELECTRONICS CORPORATION IT IS SUBJECT TO CHANGE AND THE CONTROLLING ENGINEERING ORGANIZATION SHOULD BE CONTACTED FOR THE LATEST REVISION.</small>		DWN S. WELDON 26MAR2002 CHK S. YODER 26MAR2002 APVD S. YODER 26MAR2002	BUCHANAN Tyco Electronics Harrisburg, PA 17105-3608
DIMENSIONS: INCHES	TOLERANCES UNLESS OTHERWISE SPECIFIED: 0 PLC ± 1 PLC ±0.1 2 PLC ±0.02 3 PLC ±0.000 4 PLC ±0.0000 ANGLES ± FINISH	PRODUCT SPEC APPLICATION SPEC WEIGHT	NAME CHANNEL CLAMP ASSEMBLY, #61 SIZE CAGE CODE DRAWING NO RESTRICTED TO A200779C-1447492-2 -
MATERIAL -		CUSTOMER DRAWING	SCALE 6:1 SHEET 1 OF 1 REV A