

groov EPIC Chassis

Features

- > Secure mounting for *groov*® I/O modules, power supply, and processor
- > Analog and discrete modules on the same chassis
- > Mount on a panel or 35 mm DIN-rail
- > Modules pivot into place, plug into a module connector, and lock onto the chassis with screw
- > Processor and power supply interlock and are secured with a screw
- > UL Hazardous Locations approved and ATEX compliant



GRV-EPIC-CHS4

DESCRIPTION

groov EPIC® I/O mounting chassis are designed to hold an intelligent *groov* EPIC processor, power supply, and I/O modules.

Since *groov* analog and discrete I/O modules all have the same footprint, these modules can all be mixed on the same chassis. Field devices are wired directly to the top-mounted connectors on the

modules. The module and chassis design allows modules to pivot into a specific mounting positions on the chassis.

groov EPIC chassis are available in three configurations, accommodating up to 4, 8, or 16 modules.

All *groov* power supplies, voltage converters, adapters, and processors, are UL/cUL listed and compliant with the ATEX, Low Voltage, and EMC CE directives. Each module is factory tested twice before shipment and most modules are guaranteed for life.

SPECIFICATIONS

Specification	GRV-EPIC-CHS16	GRV-EPIC-CHS8	GRV-EPIC-CHS4
Number of I/O module slots	16	8	4
Temperature (operating)	-20 °C to +70 °C	-20 °C to +70 °C	-20 °C to +70 °C
Temperature (storage)	-40 °C to +85 °C	-40 °C to +85 °C	-40 °C to +85 °C
Relative Humidity (non-condensing)	5–95%	5–95%	5–95%
Agency Approvals	UL/cUL (Class 1 Div. 2); CE, ATEX (Category 3, Zone 2), RoHS; DFARS; CB Scheme	UL/cUL (Class 1 Div. 2); CE, ATEX (Category 3, Zone 2), RoHS; DFARS; CB Scheme	UL/cUL (Class 1 Div. 2); CE, ATEX (Category 3, Zone 2), RoHS; DFARS; CB Scheme
Warranty	30 months	30 months	30 months



Part Numbers

Part	Description
GRV-EPIC-CHS4	4-module analog/discrete/serial mounting chassis
GRV-EPIC-CHS8	8-module analog/discrete/serial mounting chassis
GRV-EPIC-CHS16	16-module analog/discrete/serial mounting chassis

DIMENSIONS: GRV-EPIC-CHS4, GRV-EPIC-CHS8, AND GRV-EPIC-CHS16

Part Number	Description	Width (inches)	Width (mm)	Length (inches)	Length (mm)	Depth (inches)	Depth (mm)
GRV-EPIC-CHS4	4-module chassis	5.36	136.2	6.81	173.0	3.98	101.1 mm
GRV-EPIC-CHS8	8-module chassis	5.36	136.2	10.18	258.5	3.98	101.1 mm
GRV-EPIC-CHS16	16-module chassis	5.36	136.2	16.91	429.6	3.98	101.1 mm

Depth and Length Dimensions

GRV-EPIC-CHS4

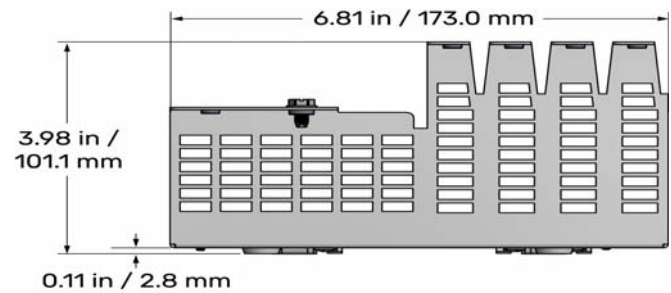

GRV-EPIC-CHS8

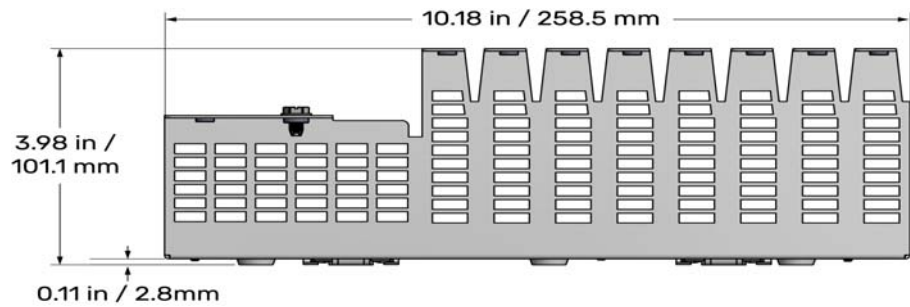

GRV-EPIC-CHS16

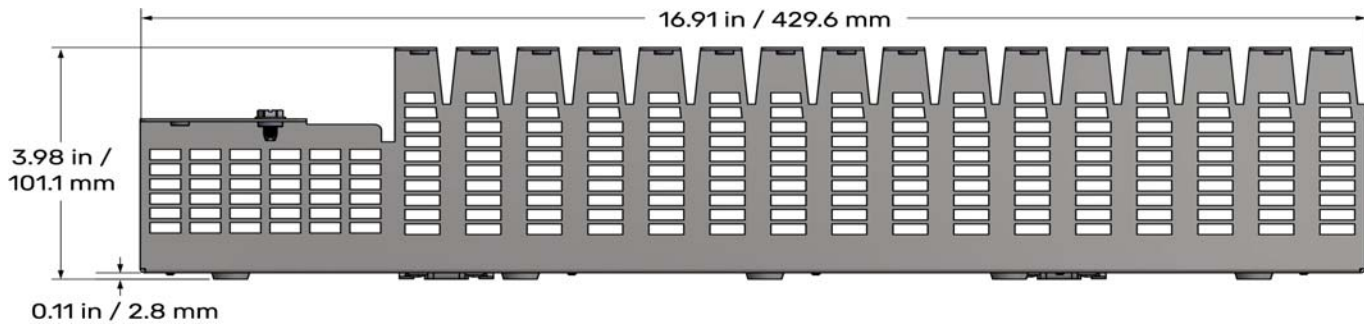

Overall Dimensions with Power Supply, Processor, and Modules Mounted

The following diagrams show the dimensions of a 16-module chassis with a power supply, processor, and 16 modules mounted on it. The DIN rail shown is a standard 35 mm DIN rail (not sold by Opto 22).

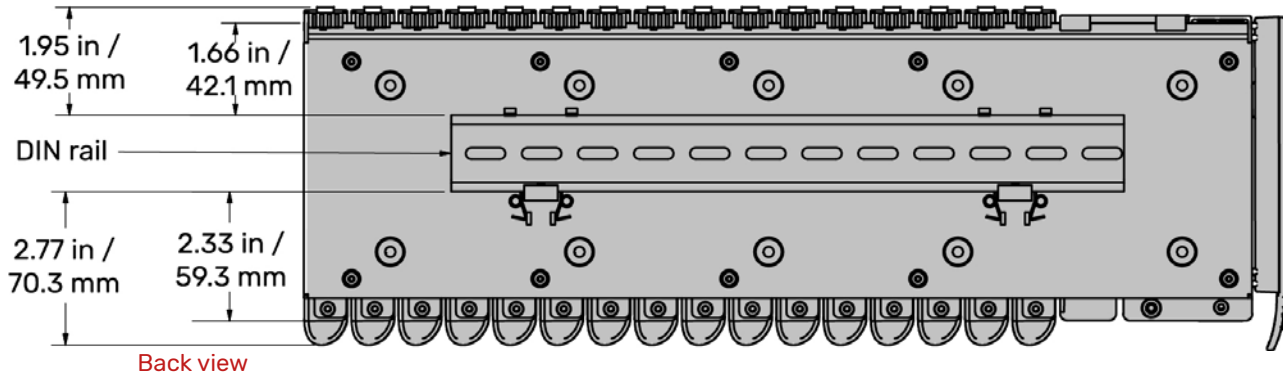

The dimensions shown in the diagram on the right show the display open, perpendicular to the closed position.

End view

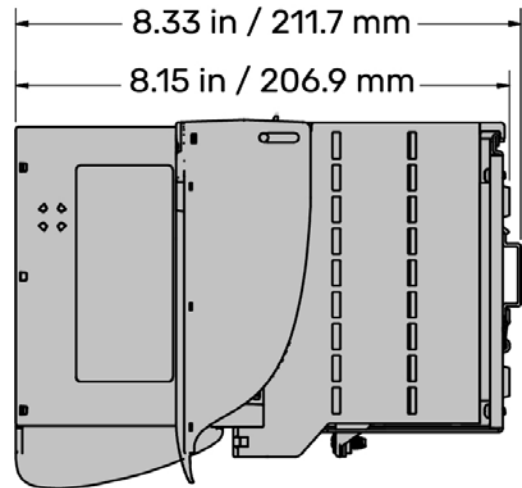

The dimensions shown in the diagram below show the display open in two positions: upright and out to its fullest extension.

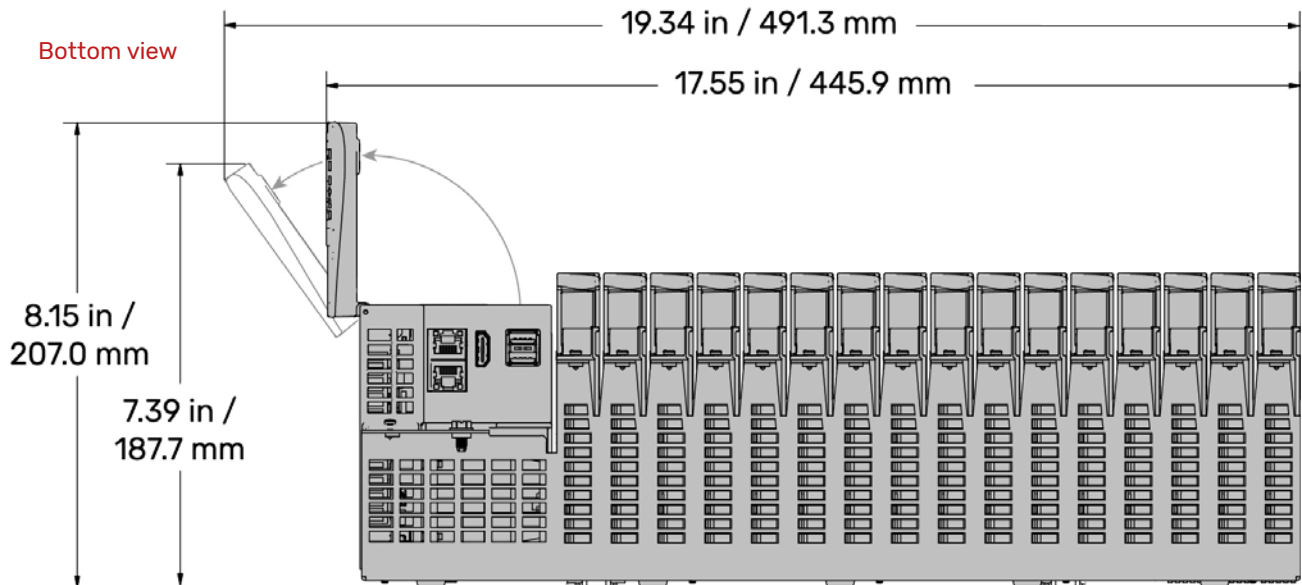

ASSEMBLING AND MOUNTING ON A DIN RAIL

The chassis is built with DIN rail adapters for use on 35 mm DIN rail. No additional assembly is required.

Mount the chassis empty. Install the *groov* EPIC products, like the power supply, the processor, and the modules, after you have mounted the chassis onto the DIN rail.

To mount the chassis on to a DIN rail, do the following tasks:

1. Hold the chassis so that the module connector numbers are facing right side up.
2. Hold the chassis at an angle such that the top of the DIN rail adapter is away from the DIN rail and the bottom of the DIN rail adapter can slide behind the bottom lip of the DIN rail.
3. Push the bottom part of the chassis upward, making sure that you feel the clip catch on to the rail, and simultaneously push the top half of the chassis toward the DIN rail until the top of the DIN rail adapter engages the top lip of the DIN rail.

Before you release the chassis, verify that the top and bottom of the DIN rail adapters have engaged the DIN rail.

4. Mount the power supply, the processor, and the modules onto the chassis.

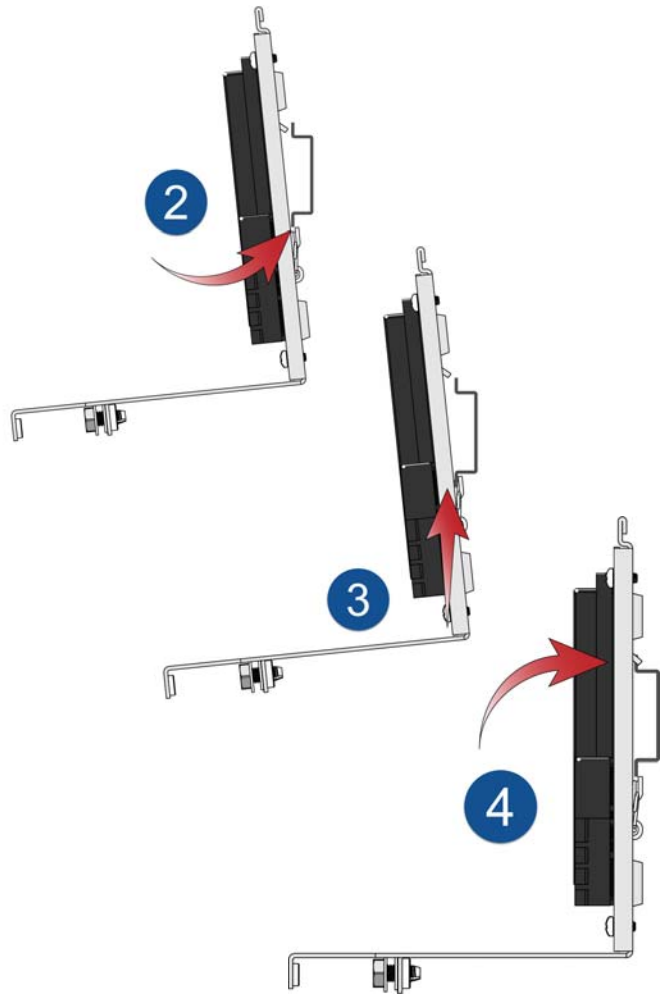

ASSEMBLING AND MOUNTING CHASSIS ON A PANEL

Using Chassis as Template

Use this method if you have the chassis on-hand to use as a template.

1. Review the mounting hole dimensions on the next page and the dimensional drawings in previous pages to determine required product and option clearances.
2. Opto 22 ships the backplane attached to the chassis, so remove the backplane to gain access to the chassis mounting holes.
3. Use the chassis as a template to mark holes.
4. After the chassis is securely mounted, attach the backplane with the retention screws provided.

Alternate Method: Prefabrication of Panels

If you do not have the chassis on-hand, review the diagrams on the next page to determine mounting hole positions.

Mounting Hole Dimensions

The following diagrams show the length measurements from the edges of the chassis to the center positions of the mounting holes.

When you install the chassis, use pan head screws of up to 10-32 in size.

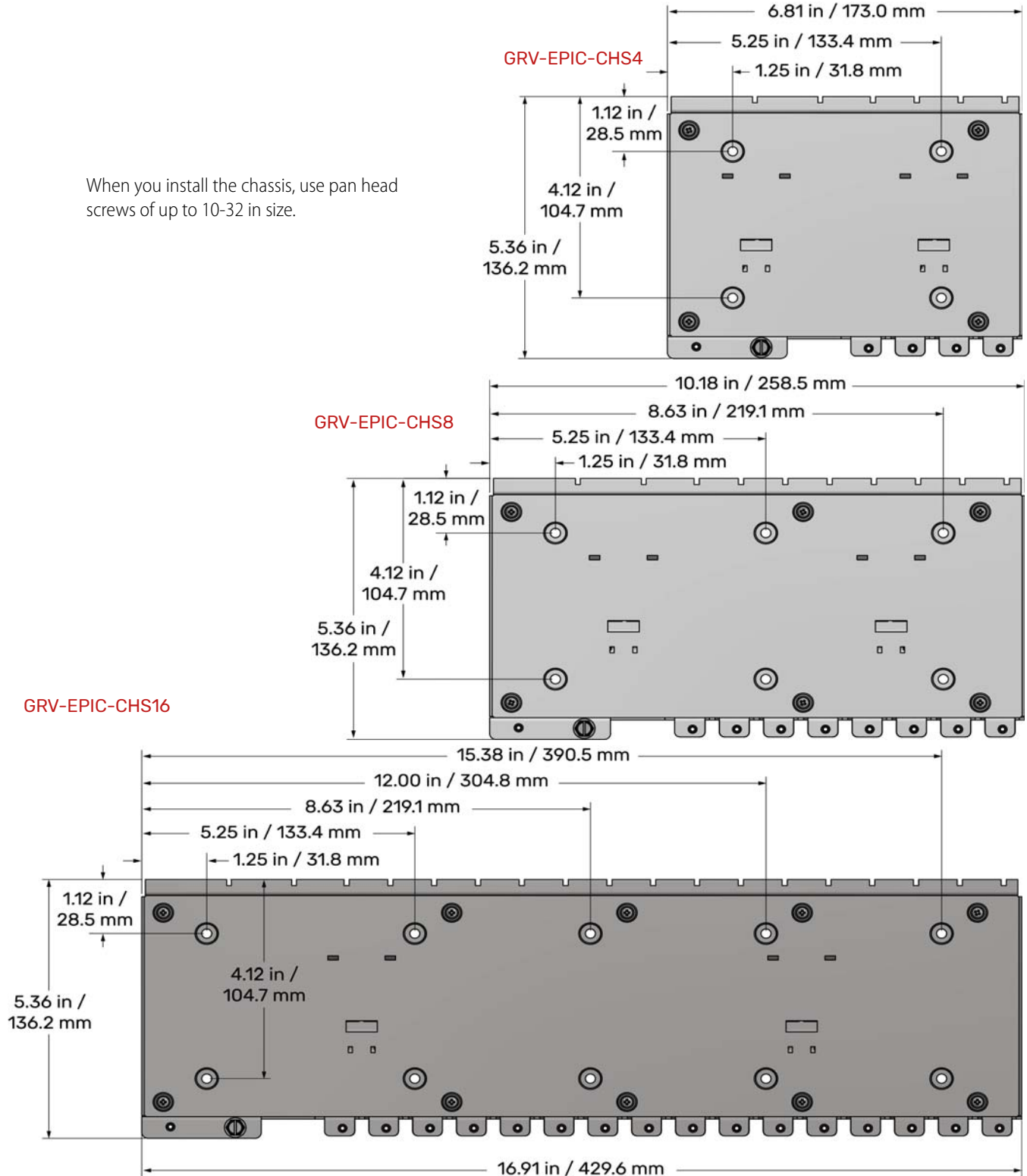

PRODUCTS

Opto 22 develops and manufactures reliable, easy-to-use, open standards-based hardware and software products.

Industrial automation, process control, building automation, industrial refrigeration, remote monitoring, data acquisition, and industrial internet of things (IIoT) applications worldwide all rely on Opto 22.

groov EPIC® System

Opto 22's *groov* Edge Programmable Industrial Controller (EPIC) system is the culmination of over 40 years of experience in designing products for the automation industry.

groov EPIC gives you an industrially hardened system with guaranteed-for-life I/O, a flexible Linux®-based controller with gateway functions, and software for your IIoT application or any application.

groov EPIC I/O

I/O provides the local connection to sensors and equipment. *groov* I/O offers up to 24 channels on each I/O module, with a spring-clamp terminal strip, integrated wireway, and swing-away cover.

Opto 22 I/O is so reliable, we can afford to guarantee it for life. *groov* I/O is hot swappable, UL Hazardous Locations approved, and ATEX compliant.

groov EPIC Controller

The heart of the system is the *groov* EPIC controller. It handles a wide range of digital, analog, and serial functions for data collection, remote monitoring, process control, and discrete and hybrid manufacturing.

In addition, the EPIC provides secure data communications among physical assets, control systems, software applications, online services, and more, both on premises and in the cloud.

Configuring and troubleshooting I/O and networking is easier with the EPIC's integrated high-resolution touchscreen. Authorized users can see your *groov* View HMI locally on the touchscreen or on a monitor connected via the HDMI or USB ports.

groov EPIC Software

Software includes:

- Flowchart-based PAC Control for control programming, or build your own custom application with optional secure shell access
- *groov* View for building and viewing your own device-independent HMI
- Node-RED for creating simple logic flows from pre-built nodes

- Ignition Edge® from Inductive Automation®, with OPC-UA drivers to Allen-Bradley®, Siemens®, and other control systems, and MQTT/Sparkplug communications for efficient IIoT data transfer

groov Edge Appliance

Visualization, data handling, and connectivity in a compact, industrial box: that's the *groov* Edge Appliance. Included are:

- *groov* View for building and viewing operator interfaces on PCs and mobile
- Node-RED for building simple logic flows
- Ignition Edge® from Inductive Automation®, for OPC-UA drivers and MQTT/Sparkplug IIoT communications



Older products

From solid state relays (our first products) to world-famous G4 and SNAP I/O, to SNAP PAC controllers, Opto 22 products last a long time. You can count on us to give you the reliability and service you expect.



QUALITY

Founded in 1974, Opto 22 has established a worldwide reputation for high-quality products. All are made in the U.S.A. at our manufacturing facility in Temecula, California.

Because we test each product twice before it leaves our factory rather than testing a sample of each batch, we can guarantee most solid-state relays and optically isolated I/O modules for life.

FREE PRODUCT SUPPORT

Opto 22's California-based Product Support Group offers free, comprehensive technical support for Opto 22 products from engineers with decades of training and experience. Support is available in English and Spanish by phone or email, Monday–Friday, 7 a.m. to 5 p.m. PST.

Support is always available on our website, including how-to videos, user's guides, the Opto 22 KnowledgeBase, troubleshooting tips, and OptoForums. In addition, free hands-on training is available at our Temecula, California headquarters, and you can [register online](#).

PURCHASING OPTO 22 PRODUCTS

Opto 22 products are sold directly and through a worldwide network of distributors, partners, and system integrators. For more information, contact Opto 22 headquarters at **800-321-6786** (toll-free in the U.S. and Canada) or **+1-951-695-3000**, or visit our website at www.opto22.com.