

High Isolation Power Transformers

EP7 Platform SMD



- Push Pull Transformer
- Reinforced insulation for isolated power supply driver
- 8mm creepage
- 5KVRms isolation (1000VRms continuous)
- UL and TUV certified

Electrical Specifications @ 25°C - Operating Temperature -40°C to +125°C

Part Number	Inductance (1-3) ($\mu\text{H} \pm 45\%$)	DCR (1-3) (Ω MAX)	DCR (4-6) (Ω MAX)	MAX (1-3) ¹ (V- μsec Max)	Turns Ratio (1:3) (6:4)	Isolated Voltage ² (Vrms)
PH9185.011NL	750	0.50	0.55	66	1CT : 1CT	5000
PH9185.012NL	450	0.40	0.80	52	1CT : 2CT	
PH9185.013NL	200	0.35	0.95	36	1CT : 3CT	
PH9185.021NL	1800	0.75	0.45	100	2CT : 1CT	
PH9185.034NL	750	0.50	0.75	66	3CT : 4CT	
PH9185.038NL	310	0.44	1.00	44	3CT : 8CT	
PH9185.043NL	1260	0.70	0.56	89	4CT : 3CT	
PH9185.083NL	2350	0.90	0.40	110	8CT : 3CT	

Notes:

- The maximum volt-usec rating limits the peak flux density to 3600 gauss when used in bi-polar drive application with 200KHz. For unipolar drive applications or a bi-polar drive with 350kHz, a maximum volt-usec could be 60% of the listed value. For Push-Pull topology, where the voltage is applied across half the primary winding turns, the maximum volts-usec needs to be derated by 50%.
- The AEC-Q200 temperature and humidity operational life testing was completed using a dielectric strength test of 5000Vdc.
- Optional Tape & Reel packing can be ordered by adding a "T" suffix to the part number (i.e. PH9185.012NL becomes PH9185.012NLT). Pulse complies to industry standard tape and reel specification EIA481.
- The "NL" suffix indicates an RoHS-compliant part number.
- Continuous isolation voltage confirmed by 125°C/1000hrs accelerated aging with the bias voltage applied between primary and secondary windings.

Mechanical

Schematic

PH9185.XXXXNL

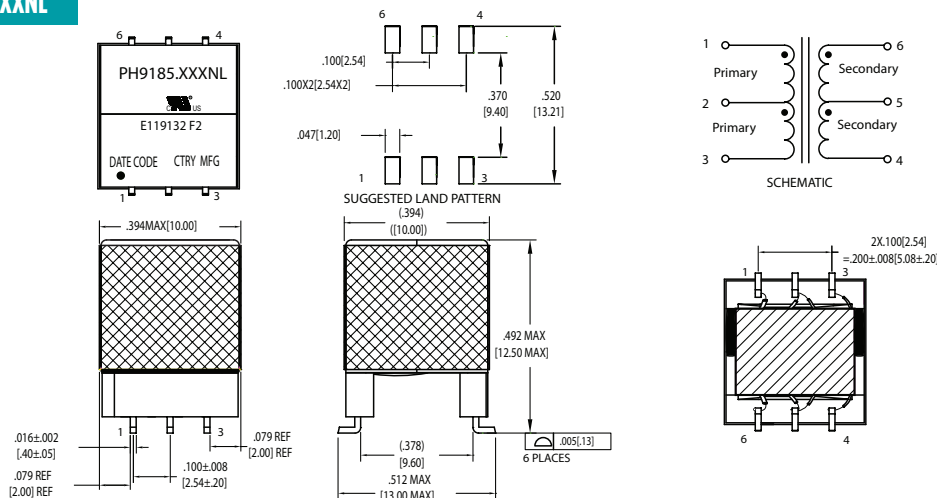

Weight2.6grams
Tape & Reel150/reel
Tray80/tray

Dimensions: $\frac{\text{Inches}}{\text{mm}}$

Unless otherwise specified, all tolerances are $\pm \frac{.010}{.25}$

USA 858 674 8100

Germany 49 2354 777 100

Singapore 65 6287 8998

Shanghai 86 21 62787060

China 86 755 33966678

Taiwan 886 3 4356768

High Isolation Power Transformers

EP7 Platform SMD

Application

PH9185.XXXNL is a series of high isolation power supply transformer drivers. Intended to operate in a fixed duty cycle Push Pull topology, it is a part of a low cost solution for delivering lower power (up to 3W) from a low voltage source. A typical implementation would be an isolated RS-485/RS-232 power supply driver circuit, the design is compatible with the MAXIM™ MAX253 IC.

A schematic diagram for the Push Pull converter topology is given below.

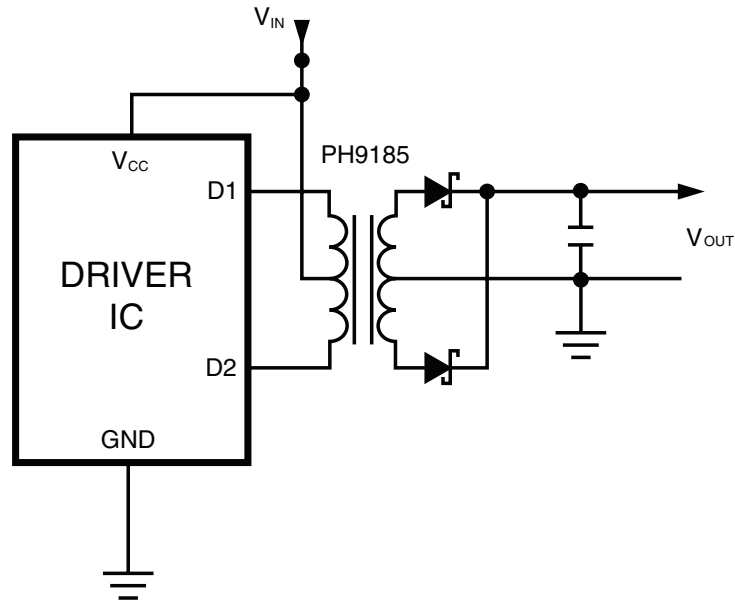

For a fixed 50% duty cycle mode of operation, the output voltage is simply determined by the input voltage and turns ratio. So, with the available turns ratios, a variety of output voltages can be selected.

This transformer design has been certified by UL to comply with UL60950-1 2nd edition, and CAN/CSA C22.2 NO. 60950-1-07 2nd edition; and by TUV to comply with EN61558-1 and EN61558-2-16 with reinforced insulation for a working voltage up to 400Vac 8mm creepage and 5000Vrms isolation voltage is guaranteed to meet this requirement. The design also complies with the Pulse's class F insulation system. PH9185.013NL was not included in the original UL/TUV certification but is compliant. Cost reduced versions without UL/TUV certification available, please contact Pulse Electronics for more information.

MAXIM is a registered trademark of Maxim Integrated Products.

For More Information

Pulse Worldwide Headquarters

15255 Innovation Dr. Ste 100
San Diego, CA 92128
U.S.A.

Tel: 858 674 8100
Fax: 858 674 8262

Pulse Europe

Pulse Electronics GmbH
Am Rottland 12
58540 Meinerzhagen
Germany

Tel: 49 2354 777 100
Fax: 49 2354 777 168

Pulse China Headquarters

B402, Shenzhen Academy of
Aerospace Technology Bldg.
10th Kejian Road
High-Tech Zone
Nanshan District
Shenzhen, PR China 518057

Tel: 86 755 33966678
Fax: 86 755 33966700

Pulse North China

Room 2704/2705
Super Ocean Finance
Ctr.
2067 Yan An Road
West
Shanghai 200336
China

Tel: 86 21 62787060
Fax: 86 2162786973

Pulse South Asia

135 Joo Seng Road
#03-02
PM Industrial Bldg.
Singapore 368363

Tel: 65 6287 8998
Fax: 65 6287 8998

Pulse North Asia

3F, No. 198
Zhongyuan Road
Zhongli City
Taoyuan County 320
Taiwan R. O. C.

Tel: 886 3 4356768
Fax: 886 3 4356823 (Pulse)
Fax: 886 3 4356820 (FRE)

Performance warranty of products offered on this data sheet is limited to the parameters specified. Data is subject to change without notice. Other brand and product names mentioned herein may be trademarks or registered trademarks of their respective owners. © Copyright, 2016. Pulse Electronics, Inc. All rights reserved.