

## LM072 Bluetooth® Module

Standalone (With Embedded Bluetooth® v2.0/v2.1 Stack)

Product	LM072
Part No.	See Last Page
Revised	2/AUG/2018
Datasheet Version	2.2



See version notes page for changes

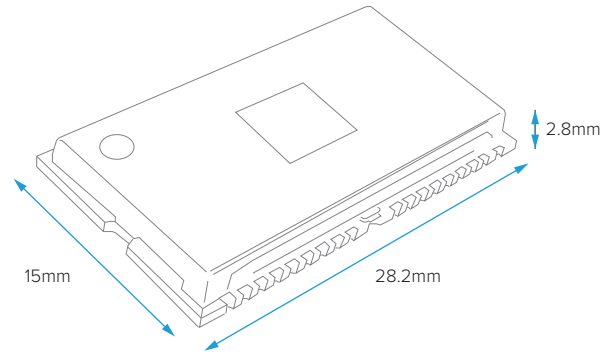

### Features

- Bluetooth® v2.0, v2.1 wireless technology
- 18 dBm Tx Output Power and -82 dBm Rx Sensitivity
- SPP and HID available
- Configurable with AT Command Set
- Up to 100m range (in open space)
- 28.2mm x 15mm x 2.8mm
- Extensive Technical Support Available
- RF Antenna Interface
- UART, USB 2.0 (Full Speed), AIO and PIO Interfaces
- RTS/ CTS Flow control UART lines
- PCM Audio Interfaces
- Configurations pre-installed on production
- SMT Side and Bottom Pads for easy production
- See our website for this products certifications.
- RoHS, REACH and WEEE

### Typical Applications

- Serial Communications
- Medical Devices
- Domestic and Industrial Applications
- Embedded Devices
- Remote Monitoring and Control
- GPS, POS, Barcode Readers
- Payment Terminals

### Overview

The LM072 Bluetooth® v2.0, v2.1 data module provides a secure and reliable Bluetooth® Classic connection. This wireless connection reaches a range of up to 100m in open space, with the option to add an antenna that suits your requirements e.g. a dipole and PCB antenna. The selected antenna could provide a longer range, omnidirectional or unidirectional connection with nearby Bluetooth® Classic devices.

The module acts as a standalone unit (i.e. no external MCU required) and/ or can interface with embedded microcontrollers via UART. Peripheral devices can be directly controlled by the module to suit the user application. LM offer technical support to the developer and can create new user applications for the module.

The AT Command set makes configuration of the firmware simple. The developed firmware and settings can be preloaded to the module, simplifying the manufacturing and testing process. Its SMT side and bottom pads allows for easy integrations into your embedded system.

## LM072 Bluetooth® Module

Standalone (With Embedded Bluetooth® v2.0/v2.1 Stack)

Product  
Part No.

LM072  
See Last Page

### General Specification

#### Wireless

Bluetooth® Standard	v2.0, v2.1 wireless technology
Module Type	Standalone (Configurable with AT Commands)
Profiles	SPP and HID

#### Hardware

Chipset	CSR
Antenna	RF Antenna Interface (Pin 37)
Flash Memory	8 Mbit
RAM	48 KB
Program Interface	SPI
Interfaces	UART, USB 2.0 (Full Speed), AIO and PIO
UART lines	RxD, TxD, RTS, CTS and GND
Full Duplex (UART)	Yes
Baud Rate (UART)	1.2, 2.4, 4.8, 9.6, 19.2, 38.4, 57.6, 115.2, 230.4, 460.8 and 921.6 Kbps
Audio Interfaces	PCM
Power Supply	3V3
Crystal Oscillator	26 MHz

#### RF Characteristics

Tx Output Power	18 dBm (Maximum)
Rx Sensitivity	-82 dBm (Typical)
Current Consumption (Cont. RX)	114 mA (Maximum)
Range	Up to 100m (in open space)
Data Rate	Up to 3Mbps
Frequency	2.4GHz to 2.485 GHz
Hopping	1,600/sec, 1MHz channel space
Modulation Scheme	GFSK-Mbps, DQPSK-2 Mbps, and 8-DPSK-3Mbps

#### Physical Characteristics

Operating Temperature	-10°C to +70°C
Dimensions (L x W x H)	28.2mm x 15mm x 2.8mm
Weight	2.29g +/- 0.25g tolerance
Certifications	See our website for this products certifications.
Compliance	RoHS, REACH and WEEE

## LM072 Bluetooth® Module

Standalone (With Embedded Bluetooth® v2.0/v2.1 Stack)

Product  
Part No.

LM072  
See Last Page

### Pin Assignments

Pin	Name	Type	Description
1	GND	Ground	Common Ground
2	PVCC	Power	Power Amp. Power supply (3.3V)
3	AIO 0	I/O	Programmable Input / Output
4	AIO 1	I/O	Programmable Input / Output
5	PIO 0	I/O	Programmable Input / Output
6	PIO 1	I/O	Programmable Input / Output
7	PIO 2	I/O	Programmable Input / Output
8	PIO 3	I/O	Programmable Input / Output
9	PIO 4	I/O	Programmable Input / Output
10	GND	Ground	Common Ground
11	PIO 5	I/O	Programmable Input / Output
12	PIO 6	I/O	Programmable Input / Output
13	PIO 7	I/O	Programmable Input / Output
14	PIO 8	I/O	Programmable Input / Output
15	PIO 9	I/O	Programmable Input / Output
16	RESET	CMOS Input	Reset Input of Module, Active Low
17	VCC	Power	Module input Supply, 3.3V DC
18	GND	Ground	Common Ground
19	GND	Ground	Common Ground
20	USB_DP	I/O	USB Data Plus
21	USB_DN	I/O	USB Data Minus
22	PCM_SYNC	I/O	Synchronous Data Sync
23	PCM_IN	CMOS Input	Synchronous Data Input
24	PCM_OUT	CMOS Output	Synchronous Data Output
25	PCM_CLK	I/O	Synchronous Data Clock
26	UART_RX	CMOS Input	UART Data Input
27	UART_TX	CMOS Output	UART Data Output
28	UART_RTS	CMOS Output	UART Request to Send (Active Low)
29	GND	Ground	Common Ground
30	UART_CTS	CMOS Input	UART Clear to Send (Active Low)
31	SPI_MOSI	CMOS Input	Serial Peripheral Interface Data Input
32	SPI_CSB	CMOS Input	Chip Select for Serial Peripheral Interface (Active Low)
33	SPI_CLK	CMOS Input	Serial Peripheral Interface Clock
34	SPI_MISO	CMOS Output	Serial Peripheral Interface Data Output
35	PIO 11	I/O	Programmable Input Output
36	PIO 10	I/O	Programmable Input Output
37	RF_IO	Analogue	Antenna Interface
38	GND	Ground	Common Ground

# LM072 Bluetooth® Module

## Standalone (With Embedded Bluetooth® v2.0/v2.1 Stack)

Product  
Part No.

LM072  
See Last Page

### General Electrical Specification

Parameter	Description	Min	Typical	Max	Units
Carrier Frequency	-	2.402	-	2.480	GHz
RF Output Power	Measured with 50Ω ant	15	16.5	18	dBm
Rx Sensitivity	-	-	-88	-86	dBm
Load Impedance	No abnormal oscillation	-	-	5:1	-
Input Low Voltage	RESET, UART, GPIO, PCM	-0.3	-	0.8	DCV
Input High Voltage	RESET, UART, GPIO, PCM	0.7VDD	-	VDD+0.3	DCV
Output Low Voltage	UART, GPIO, PCM	-	-	0.4	DCV
Output High Voltage	UART, GPIO, PCM	VDD-0.4	-	-	DCV
Average Current Consumption	Receive DM1	-	114	-	mA

### Block Diagram

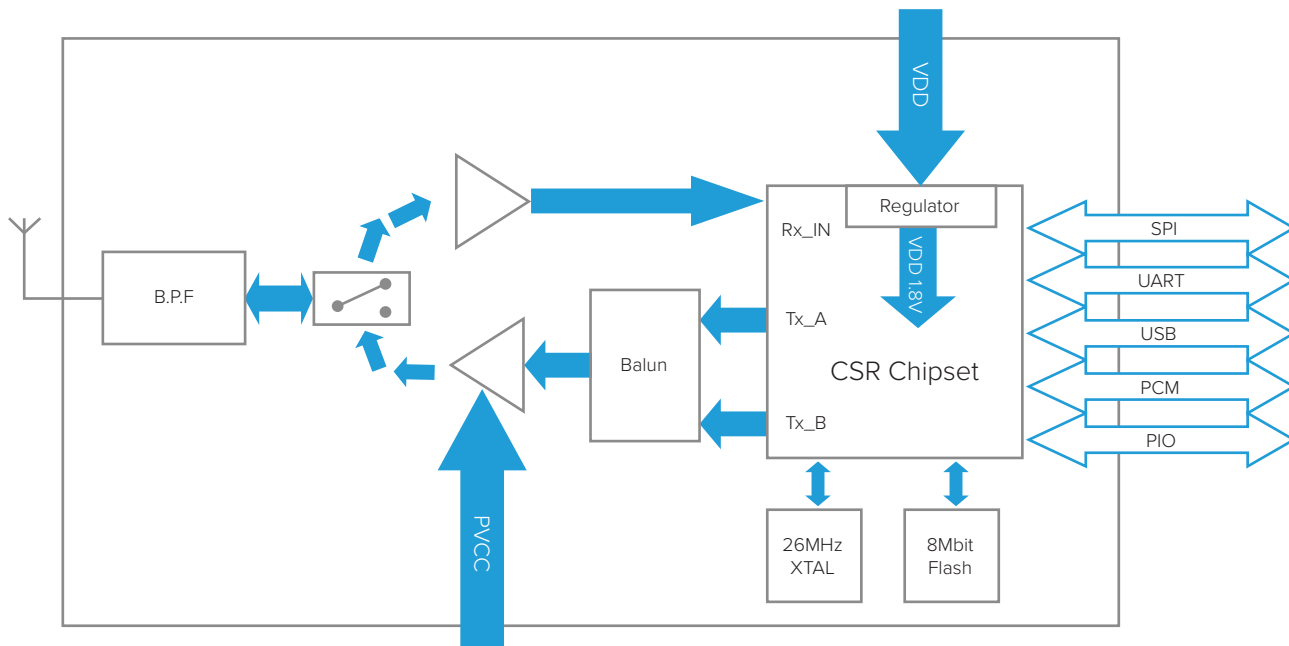

Note: USB and PCM interface are not handled by LM firmware at present

### Factory Settings

The factory settings of the COM Port are as follows:

Baud Rate	19200 bps
Data Bits	8
Parity	None
Stop Bits	1
Flow Control	Hardware (BT2.0) or None (BT2.1)

# LM072 Bluetooth® Module

Standalone (With Embedded Bluetooth® v2.0/v2.1 Stack)

Product  
Part No.

LM072  
See Last Page

## Electrical Characteristics Absolute Maximum Ratings

Parameter	Min	Max	Units
Storage Temperature	-40	+85	°C
Supply Voltage (VDD)	+2.7	+3.6	V
Supply Voltage (PVCC)	+3.0	+3.6	V
All other pins	VSS - 0.4	VDD+0.4	V

## Electrical Characteristics Recommended Operating Conditions

Parameter	Min	Max	Units
Storage Temperature	-20	+75	°C
Supply Voltage (VDD)	+3.0	+3.3	V
Supply Voltage (PVCC)	+3.0	+3.3	V

## Dimensions All measurements in mm

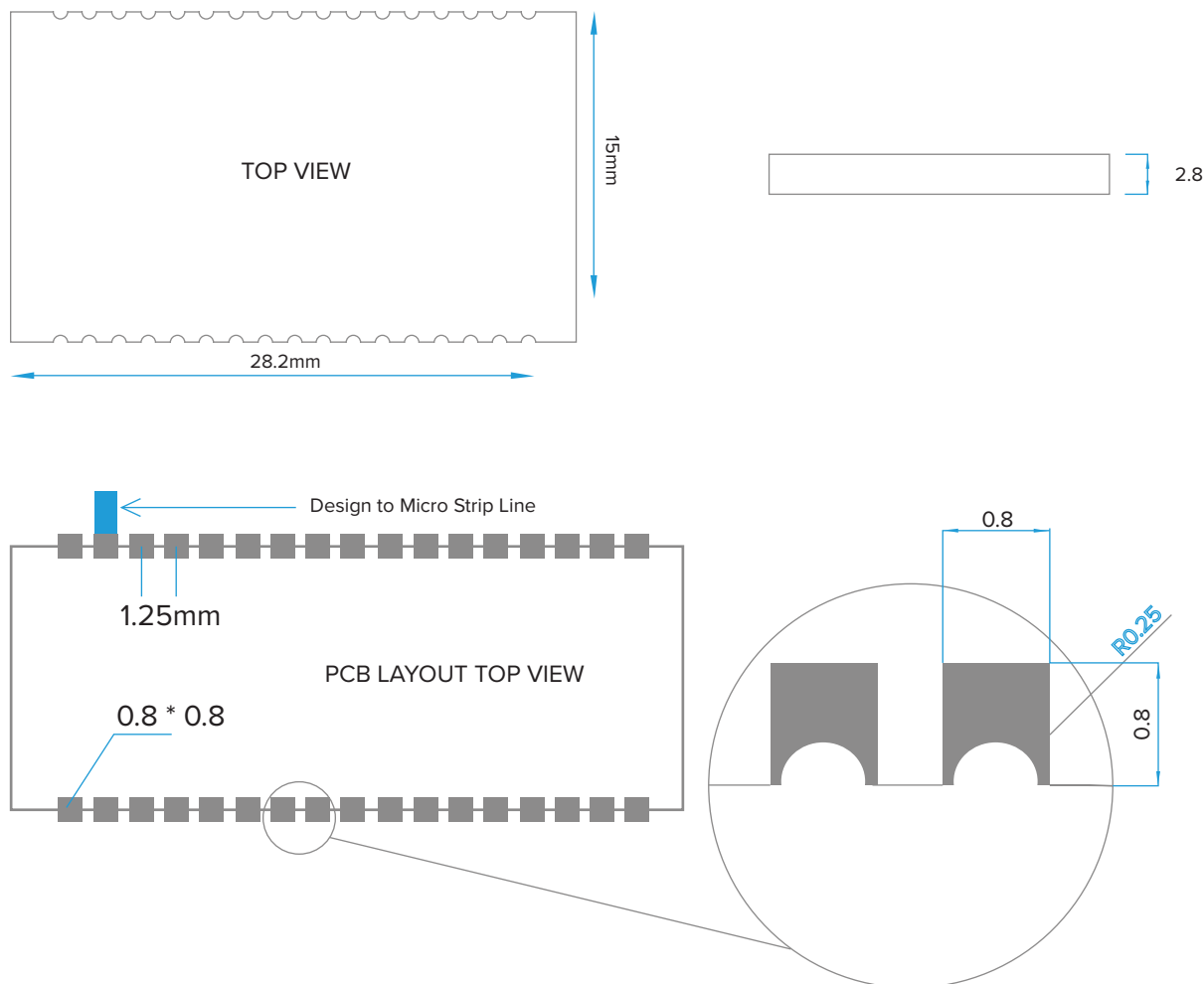

# LM072 Bluetooth® Module

Standalone (With Embedded Bluetooth® v2.0/v2.1 Stack)

Product  
Part No.

LM072  
See Last Page

## Tape and Reel Packaging

### Tape Dimensions

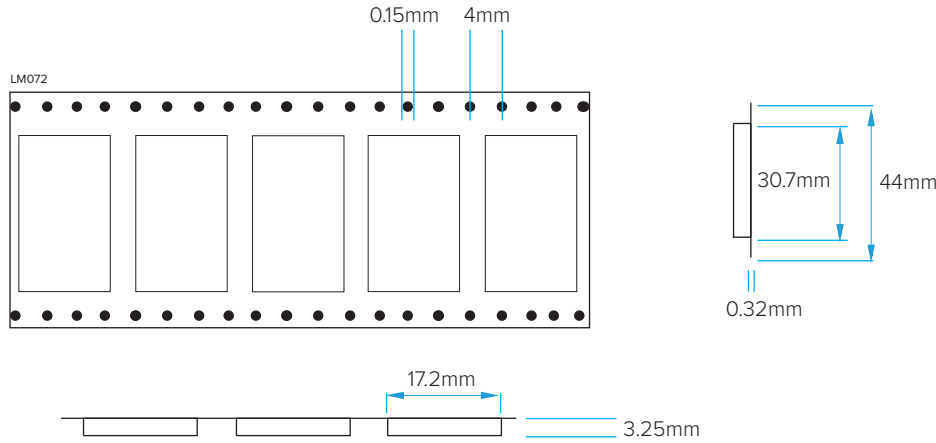

### Reel Dimensions

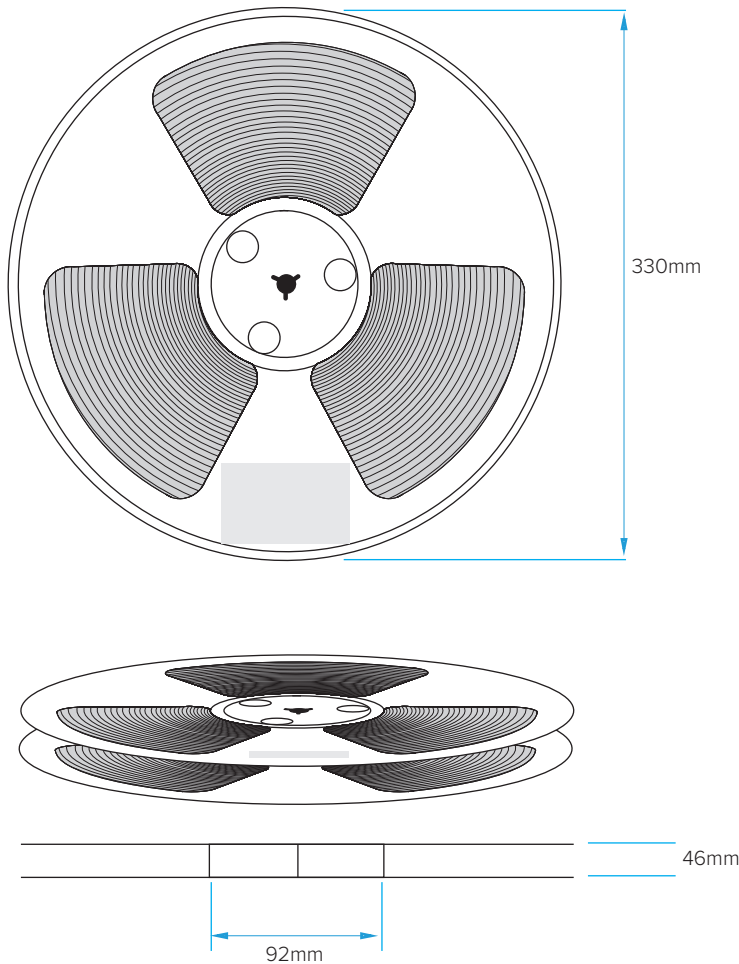

#### Notes

- Carton Dimensions (L x W x H): 360mm x 280mm x 370mm

#### Quantities

- 900 modules per Tape
- 4 Boxes per Carton
- 3600 modules per Carton

**LM072 Bluetooth® Module**  
 Standalone (With Embedded Bluetooth® v2.0/v2.1 Stack)

Product  
 Part No.

LM072  
 See Last Page

**Tray Packaging**

Tray Dimensions

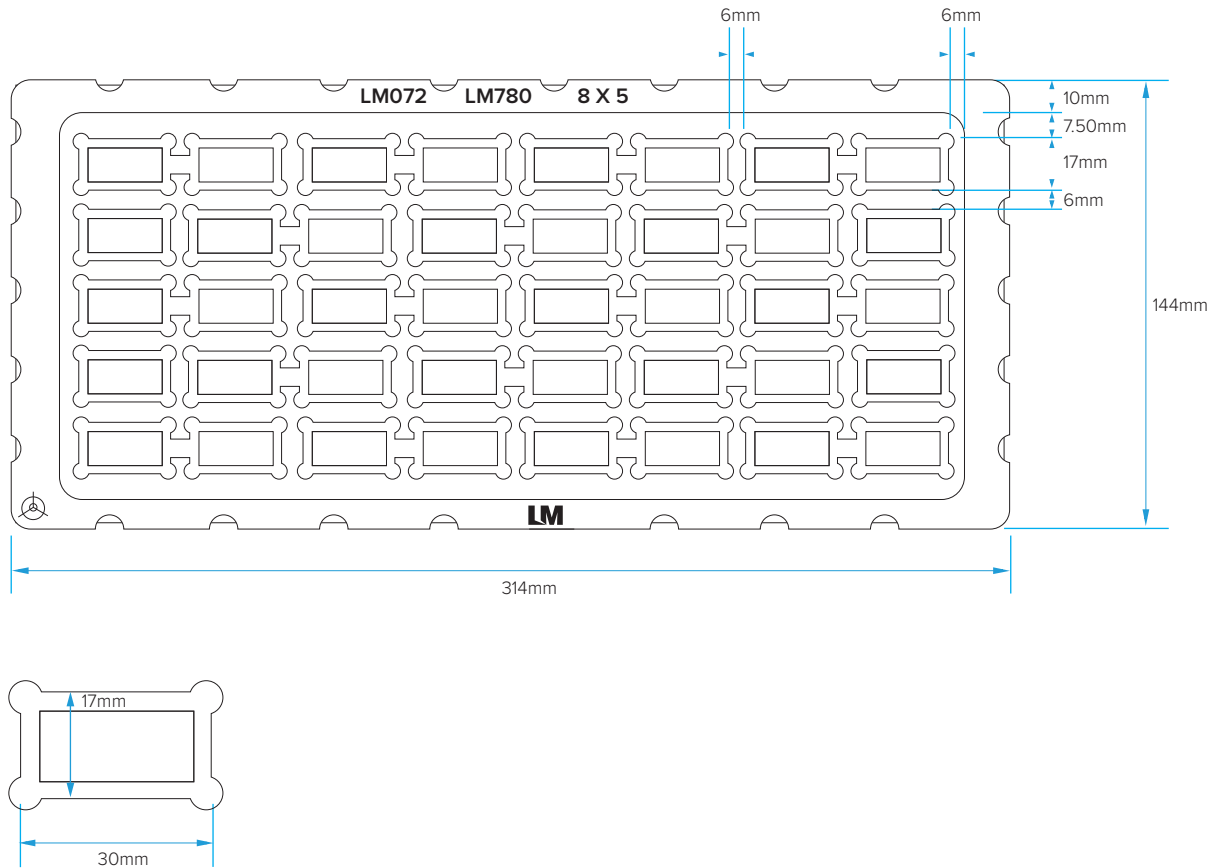

**Notes**

- Anti-Static PS Tray, Black .
- Electrical Resistance:  $1\text{ M}\Omega < R < 100\text{ M}\Omega$  .
- Thickness:  $T = 0.8\text{ mm}$
- Carton Dimensions (L x W x H):  
 312mm x 141mm x 7.5mm

**Quantities**

- 40 modules per Tray
- 400 modules per Box
- 4 Boxes per Carton
- 1600 modules per Carton



## LM072 Bluetooth® Module

### Standalone (With Embedded Bluetooth® v2.0/v2.1 Stack)

Product  
Part No.

LM072  
See Last Page

### FCC Warning

This device complies with Part 15 of the FCC Rules. Operation is subject to the following two conditions:

- (1) this device may not cause harmful interference, and
- (2) this device must accept any interference received, including interference that may cause undesired operation.

#### NOTE 1

This equipment has been tested and found to comply with the limits for a Class B digital device, pursuant to part 15 of the FCC Rules. These limits are designed to provide reasonable protection against harmful interference in a residential installation. This equipment generates, uses and can radiate radio frequency energy and, if not installed and used in accordance with the instructions, may cause harmful interference to radio communications. However, there is no guarantee that interference will not occur in a particular installation. If this equipment does cause harmful interference to radio or television reception, which can be determined by turning the equipment off and on, the user is encouraged to try to correct the interference by one or more of the following measures:

- Reorient or relocate the receiving antenna.
- Increase the separation between the equipment and receiver.
- Connect the equipment into an outlet on a circuit different from that to which the receiver is connected.
- Consult the dealer or an experienced radio/TV technician for help.

#### NOTE 2

Any changes or modifications to this unit not expressly approved by the party responsible for compliance could void the user's authority to operate the equipment.

### FCC Radiation Exposure Statement

This equipment complies with FCC radiation exposure limits set forth for an uncontrolled environment. End users must follow the specific operating instructions for satisfying RF exposure compliance.

#### Note 1

This module certified that complies with RF exposure requirement under portable or mobile or fixed condition, this module is to be installed only in portable or mobile or fixed applications.

A portable device is defined as a transmitting device designed to be used so that the radiating structure(s) of the device is/are within 20 centimeters of the body of the user

A mobile device is defined as a transmitting device designed to be used in other than fixed locations and to generally be used in such a way that a separation distance of at least 20 centimeters is normally maintained between the transmitter's radiating structure(s) and the body of the user or nearby persons. Transmitting devices designed to be used by consumers or workers that can be easily re-located, such as wireless devices associated with a personal computer, are considered to be mobile devices if they meet the 20 centimeter separation requirement.

A fixed device is defined as a device is physically secured at one location and is not able to be easily moved to another location.

#### Note 2

Any modifications made to the module will void the Grant of Certification, this module is limited to OEM installation only and must not be sold to end-users, end-user has no manual instructions to remove or install the device, only software or operating procedure shall be placed in the end-user operating manual of final products.

#### Note 3

The device must not transmit simultaneously with any other antenna or transmitter.



## LM072 Bluetooth® Module

Standalone (With Embedded Bluetooth® v2.0/v2.1 Stack)

Product

LM072

Part No.

See Last Page

### FCC Radiation Exposure Statement (Continued)

#### Note 4

To ensure compliance with all non-transmitter functions the host manufacturer is responsible for ensuring compliance with the module(s) installed and fully operational. For example, if a host was previously authorized as an unintentional radiator under the Declaration of Conformity procedure without a transmitter certified module and a module is added, the host manufacturer is responsible for ensuring that after the module is installed and operational the host continues to be compliant with the Part 15B unintentional radiator requirements. Since this may depend on the details of how the module is integrated with the host, LM Technologies Ltd shall provide guidance to the host manufacturer for compliance with the Part 15B requirements.

#### Note 5

FCC ID label on the final system must be labeled with “Contains FCC ID: VVXLM072” or “Contains transmitter module FCC ID: VVXLM072”.

The transmitter module must be installed and used in strict accordance with the manufacturer’s instructions as described in the user documentation that comes with the host product. LM Technologies Ltd is responsible for the compliance of the module in all final hosts.



## LM072 Bluetooth® Module

Standalone (With Embedded Bluetooth® v2.0/v2.1 Stack)

Product

LM072

Part No.

See Last Page

### Datasheet Version Notes

v1.0	13 MAR 2018	Added version notes to datasheet.
v2.0	1 MAY 2018	New LM072 version 2 release (with new power amplifier replacing previous).
v2.1	29 MAY 2018	New Part Numbers released for LM072 version 2.
v2.2	2 AUG 2018	Part Number Revisions added for LM072 version 2. (See Last Page)

**LM072 Bluetooth® Module**  
 Standalone (With Embedded Bluetooth® v2.0/v2.1 Stack)

Product  
 Part No.

LM072  
 See Below

**LM072 Packaging Options**

**Bluetooth® v2.0**

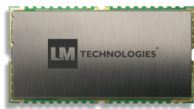

072-3110

Previously 072-0110

**LM072 Bluetooth® v2.0 Module**

MOD SMT PROG BT2.0 USB\_UART Fw6.6.x 1.8-3.3v No-ANT SP

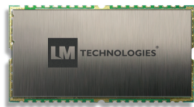

072-3111

Previously 072-0111

**LM072 Bluetooth® v2.0 Module**

MOD SMT PROG BT2.0 USB\_UART Fw6.6.x 1.8-3.3v No-ANT TRAY



072-3112

Previously 072-0112

**LM072 Bluetooth® v2.0 Module**

MOD SMT PROG BT2.0 USB\_UART Fw6.6.x 1.8-3.3v No-ANT T&R

**Bluetooth® v2.1**

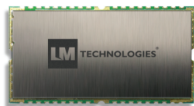

072-3115

**LM072 Bluetooth® v2.1 Module**

MOD SMT PROG BT2.1 USB\_UART Fw6.1x 1.8-3.3v No-ANT TRAY

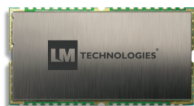

072-3126

**LM072 Bluetooth® v2.1 Module**

MOD SMT PROG BT2.1 USB\_UART Fw6.1x 1.8-3.3v No-ANT T&R

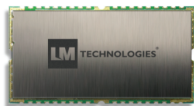

072-3127

**LM072 Bluetooth® v2.1 Module**

MOD SMT PROG BT2.1 USB\_UART Fw6.1x 1.8-3.3v No-ANT T&R

• Product User Guides, Manuals and Configuration Software is available to download via our website - <http://www.lm-technologies.com/downloads>