

POWER OPTIMIZED MEMS OSCILLATORS

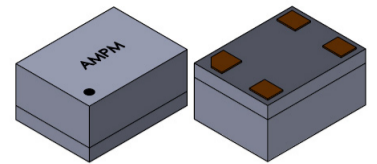

AMPM-SERIES



ESD Sensitive



RoHS/RoHS II Compliant

MSL = MSL 1

1.6 x 1.2 x 0.84 mm
2.0 x 1.6 x 0.84 mm
2.5 x 2.0 x 0.84 mm
3.2 x 2.5 x 0.85 mm

FEATURES

- Compact footprint as small as 1.6x1.2mm
- Low 0.84mm profile
- Low power consumption
- 1MHz to 80MHz output frequency range
- Short lead time for new frequencies
- Wide -40°C to +85°C operating temperature range
- Output enable or ultra-low power standby: 12µA (typ)
- Low operating current: 1.3mA IDD (typ)

APPLICATIONS

- Wearables
- Internet of Things (IoT)
- Industrial IoT
- Audio and video
- Drones and robotics

ELECTRICAL SPECIFICATIONS

Electrical characteristics unless otherwise indicated, $V_{DD} = 1.8V -5\% \text{ to } 3.3V +10\%$, temperature range -40°C to 85 °C

Parameters	Min.	Typ.	Max.	Units	Note
Frequency Range	1.0000		80.0000	MHz	
Power Supply Voltage (V_{DD})	1.71		3.63	V	
Current Consumption (I_{DD})		1.3		mA	$f_{out} = 24\text{MHz}$, $V_{DD} = 1.8\text{V}$, No Load
Standby Current Consumption (I_{STBY})		12	30	µA	$V_{DD} = 1.8/2.5\text{V}$
		80	160		$V_{DD} = 3.3\text{V}$
Operating Temperature Range	-40		+85	°C	See Options
Storage Temperature	-55		+150	°C	
All Inclusive Frequency Stability	-25		+25	ppm	Options "D" or "F"
	-50		+50		Options "E" or "G"
Aging	-5		+5	ppm	1 st year @25°C
	-1		+1		Per year after first year
Duty Cycle	45		55	%	1 MHz to 39 MHz
	40		60		61 MHz to 80 MHz 40 MHz to 60 MHz
Output Logic Levels	V_{OH}	$0.8 \cdot V_{DD}$		V	Logic High I = 1 mA
	V_{OL}		$0.2 \cdot V_{DD}$		Logic Low I = -1 mA
Input Logic Levels	V_{IH}	$0.7 \cdot V_{DD}$		V	Logic High
	V_{IL}		$0.3 \cdot V_{DD}$		Logic Low
Enable Pull-Up Resistor		300		kΩ	
Power Supply Ramp (t_{PU})	0.1		100	ms	Time to 90% targeted V_{DD}
Start-up Time (t_{SU})			1.3	ms	From 90% V_{DD} to valid clock output, @ 25°C



5101 Hidden Creek Ln Spicewood TX 78669
Phone: 512-371-6159 | Fax: 512-351-8858
For terms and conditions of sales, please visit:
www.abracon.com

REVISED: 07.02.2018

ABRACON IS
ISO9001-2015
CERTIFIED

POWER OPTIMIZED MEMS OSCILLATORS

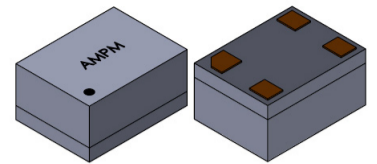

AMPM-SERIES



ESD Sensitive



RoHS/RoHS II Compliant

MSL = MSL 1

1.6 x 1.2 x 0.84 mm
2.0 x 1.6 x 0.84 mm
2.5 x 2.0 x 0.84 mm
3.2 x 2.5 x 0.85 mm

ELECTRICAL SPECIFICATIONS

Parameters		min	Typ.	Max.	Units	Note
Output Enable Time (t_{EN})				1	μ s	
Output Disable Time (t_{DA})				200+period	ns	
Rise(T_r)/Fall (T_f) Time	Low Drive 20% \leftrightarrow 80%		2.5	3.5	ns	CL = 5 pF $V_{DD} = 1.8V$
			1.5	2.2		CL = 5 pF $V_{DD} = 2.5V/3.3V$
	Std Drive 20% \leftrightarrow 80%		1.2	2.0		CL = 10 pF $V_{DD} = 1.8V$
			0.6	1.2		CL = 10 pF $V_{DD} = 2.5V/3.3V$
RMS Period Jitter	Low Drive $f_{out} = 27$ MHz		32	40	ps	$V_{DD} = 1.8V$
			25	32		$V_{DD} = 2.5/3.3V$
	Std Drive $f_{out} = 27$ MHz		23	30		$V_{DD} = 1.8V$
			20	28		$V_{DD} = 2.5/3.3V$
Cycle-to-Cycle Jitter (Peak)	Low Drive $f_{out} = 27$ MHz		180	240	ps	$V_{DD} = 1.8V$
			120	170		$V_{DD} = 2.5/3.3V$
	Std Drive $f_{out} = 27$ MHz		115	190		$V_{DD} = 1.8V$
			90	150		$V_{DD} = 2.5/3.3V$

ABSOLUTE MAXIMUM RATINGS

Parameters	min	Typ.	Max.	Units	Note
Supply Voltage	-0.3		+4.0	V	
Input Voltage	-0.3		$V_{DD} + 0.3$	V	
Maximum Junction Temperature			+150	$^{\circ}C$	
Ambient Operating Temperature	-40		+85	$^{\circ}C$	Industrial
Ambient Operating Temperature	-20		+70	$^{\circ}C$	Extended Commercial
Storage Ambient Temperature Range	-55		+150	$^{\circ}C$	
Soldering Temperature		+260		$^{\circ}C$	40 Sec Maximum
ESD Protection	4 kV HBM, 400V MM, 2 kV CDM				

REVISED: 07.02.2018



5101 Hidden Creek Ln Spicewood TX 78669
Phone: 512-371-6159 | Fax: 512-351-8858
For terms and conditions of sales, please visit:
www.abracon.com

ABRACON IS
ISO9001-2015
CERTIFIED

POWER OPTIMIZED MEMS OSCILLATORS

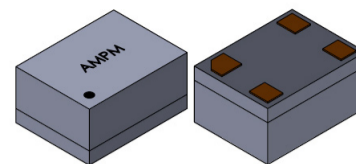

AMPM-SERIES



ESD Sensitive



RoHS/RoHS II Compliant

MSL = MSL 1

1.6 x 1.2 x 0.84 mm
2.0 x 1.6 x 0.84 mm
2.5 x 2.0 x 0.84 mm
3.2 x 2.5 x 0.85 mm

OPTIONS AND PART IDENTIFICATION

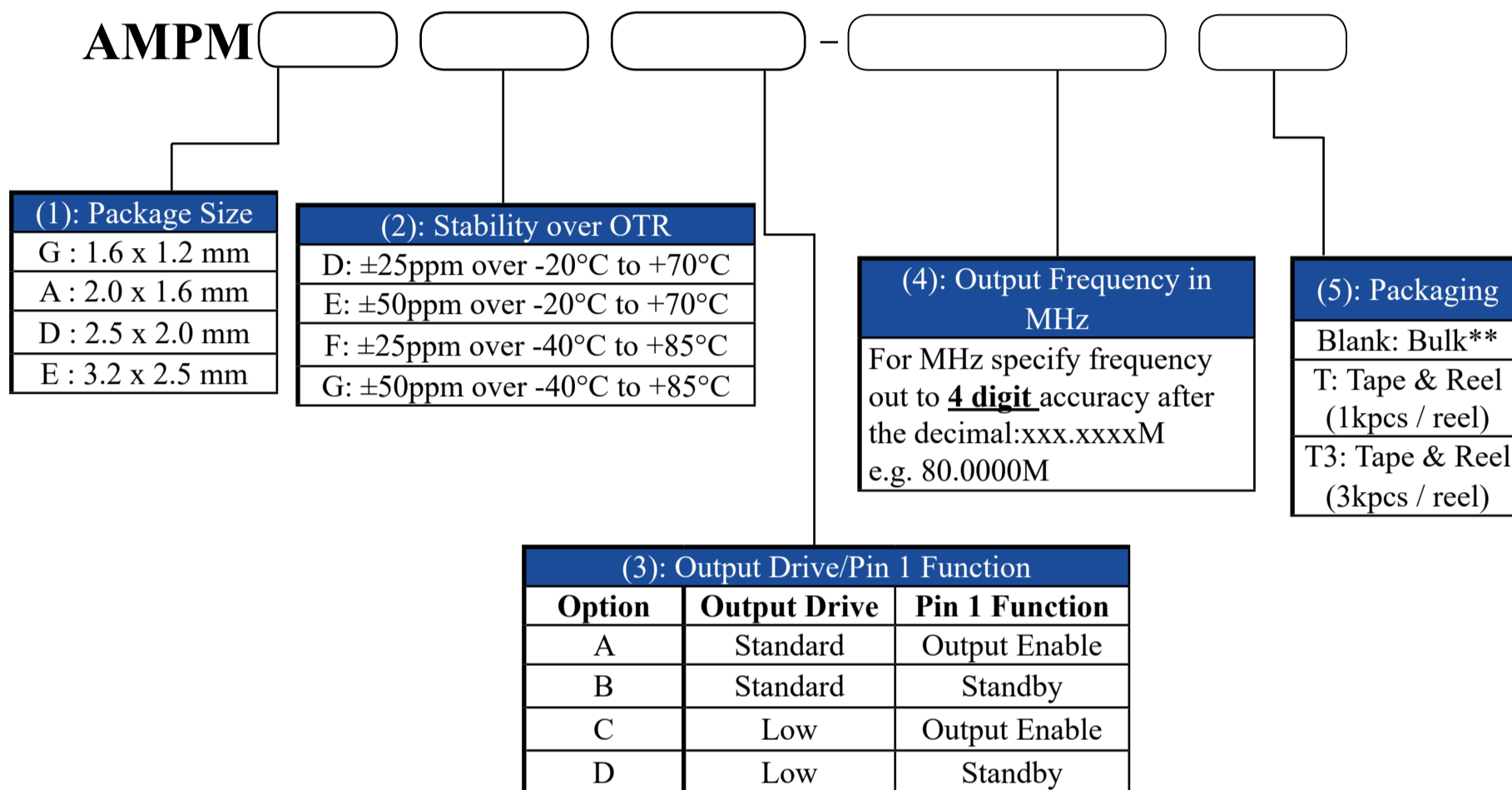

Part Number Example:

AMPMGGD - 16.0000MT

**MOQ per package:

1.6x1.2mm: 100pcs/bag

2.0x1.6mm: 100pcs/bag

2.5x2.0mm: 140 pcs/tube

3.2x2.5mm: 110 pcs/tube

For Quick turn-around programmable sample orders less than MOQ represented above:

Due to the immediate availability of stock and the qty of the order, the parts may be delivered as Cut Tape, Loose parts in Antistatic Bag or in Tube(s).

For orders greater than MOQ and less than 1000pcs:

Due to packaging, the order must be a multiple of MOQ per package size above

For orders greater than 1000pcs:

Bulk is not an option. Please refer to tape and reel packaging.



5101 Hidden Creek Ln Spicewood TX 78669

Phone: 512-371-6159 | Fax: 512-351-8858

For terms and conditions of sales, please visit:

www.abracon.com

REVISED: 07.02.2018

ABRACON IS
ISO9001-2015
CERTIFIED

POWER OPTIMIZED MEMS OSCILLATORS

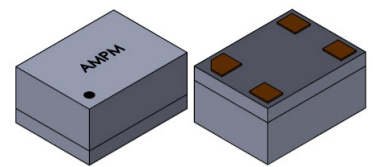

AMPM-SERIES



ESD Sensitive



RoHS/RoHS II Compliant

MSL = MSL 1

1.6 x 1.2 x 0.84 mm
2.0 x 1.6 x 0.84 mm
2.5 x 2.0 x 0.84 mm
3.2 x 2.5 x 0.85 mm

TYPICAL PERFORMANCE DATA @ 25°C ± 3°C

Current Consumption vs Frequency

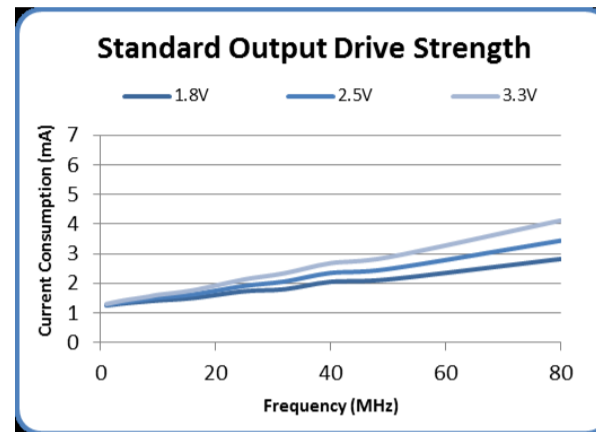
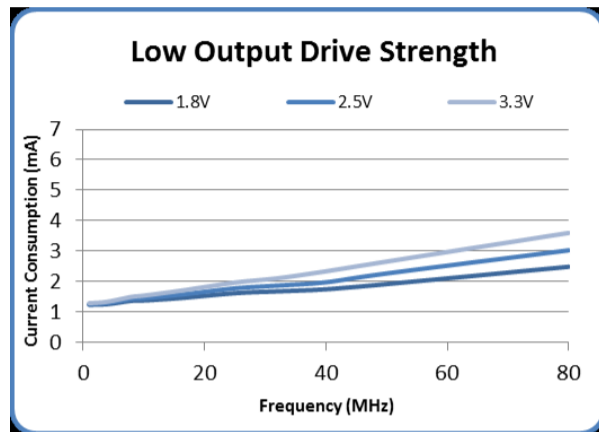

Current Consumption vs Supply Voltage

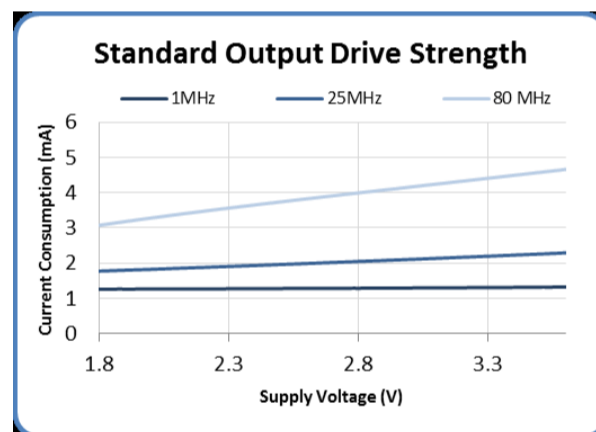
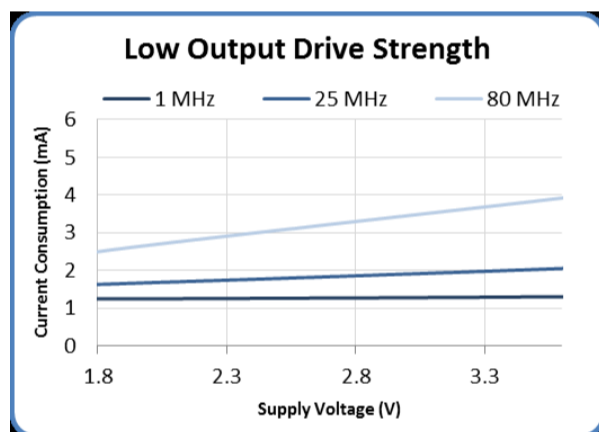

PINFUNCTIONS

Pin Number	Pin Name	Description
1	OE	Output Enable ^{Note 1&3} : High or Open = Specified Frequency Output Low = Output is high impedance
	STBY	Standby ^{Note 1&3} : High or Open = Specified Frequency Output Low = Output is high impedance, Device is in low power mode, Supply current is I_{STBY}
2	GND	Power Supply Ground
3	Output	Oscillator clock output
4	V _{DD}	Power supply ^{Note 2}

Notes :

1. If pin 1 is high or floating, there will be frequency output. If pin 1 is low, output will be disengaged.
2. Bypass with 0.1 μ F capacitor placed as close to VDD pin as possible.
3. 300 K Ω internal pull-up resistor present on pin 1.



5101 Hidden Creek Ln Spicewood TX 78669
Phone: 512-371-6159 | Fax: 512-351-8858
For terms and conditions of sales, please visit:
www.abracon.com

REVISED: 07.02.2018

ABRACON IS
ISO9001-2015
CERTIFIED

POWER OPTIMIZED MEMS OSCILLATORS

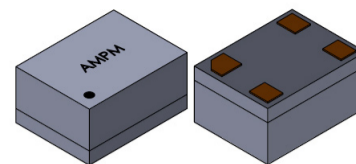

AMPM-SERIES



ESD Sensitive



RoHS/RoHS II Compliant

MSL = MSL 1

1.6 x 1.2 x 0.84 mm
2.0 x 1.6 x 0.84 mm
2.5 x 2.0 x 0.84 mm
3.2 x 2.5 x 0.85 mm

OUTPUT BUFFER OPTIONS

The AMPM Series is available in multiple output driver configurations. The low-power driver minimizes current consumption and EMI while delivering greater than 1 mA output current at 20% to 80% of the supply voltage. The standard-drive delivers greater than 3 mA output current at 20% to 80% of the supply voltage.

DIAGRAMS

Output Waveform

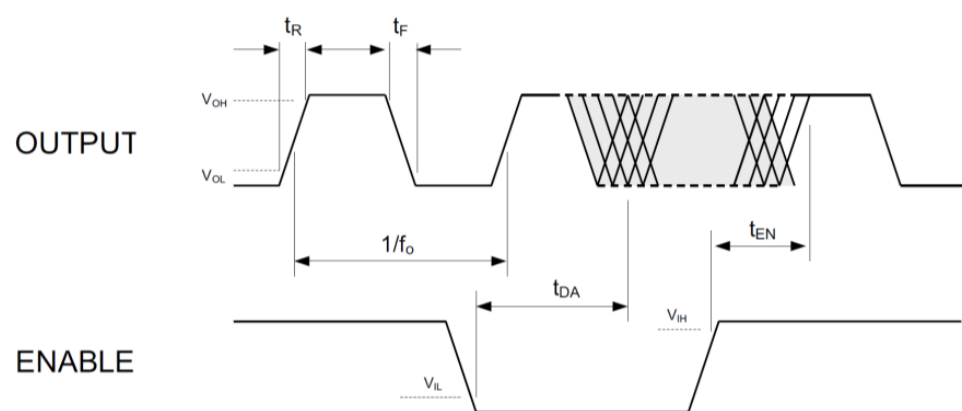

Test Circuit

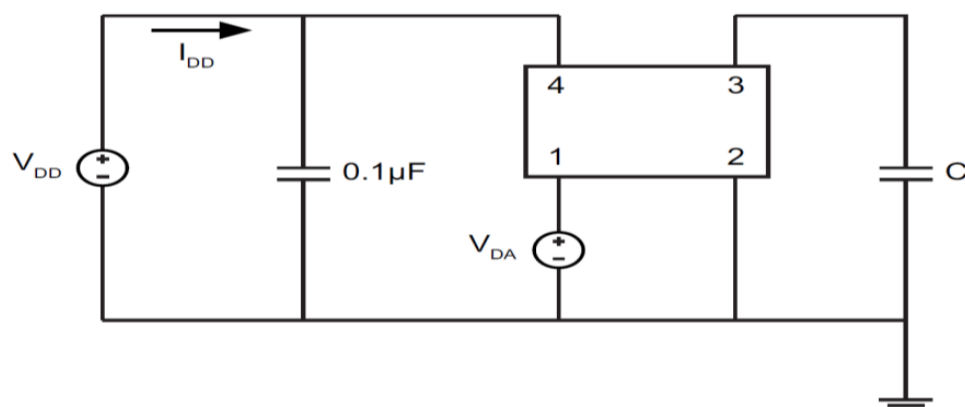

Recommended Board Layout

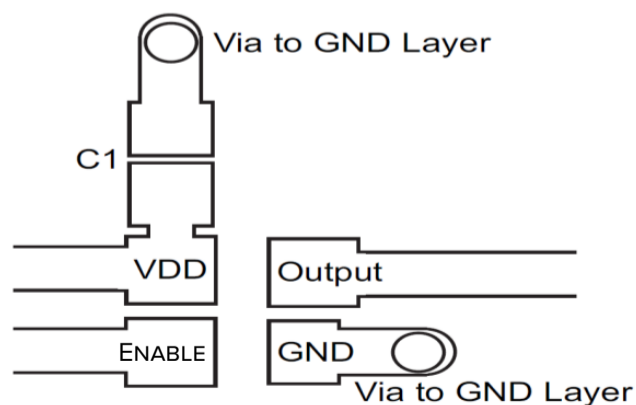

POWER OPTIMIZED MEMS OSCILLATORS

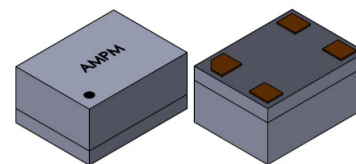

AMPM-SERIES



ESD Sensitive



RoHS/RoHS II Compliant

1.6 x 1.2 x 0.84 mm
2.0 x 1.6 x 0.84 mm
2.5 x 2.0 x 0.84 mm
3.2 x 2.5 x 0.85 mm

MSL = MSL 1

MARKING

1.6 mm x 1.2 mm VFLGA
2.0 mm x 1.6 mm VFLGA

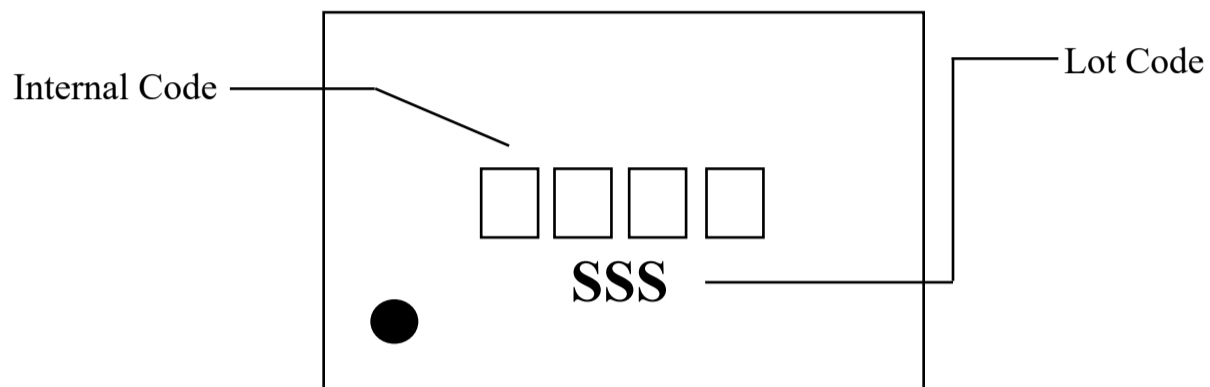

2.5 mm x 2.0 mm VLGA
3.2 mm x 2.5 mm DFN

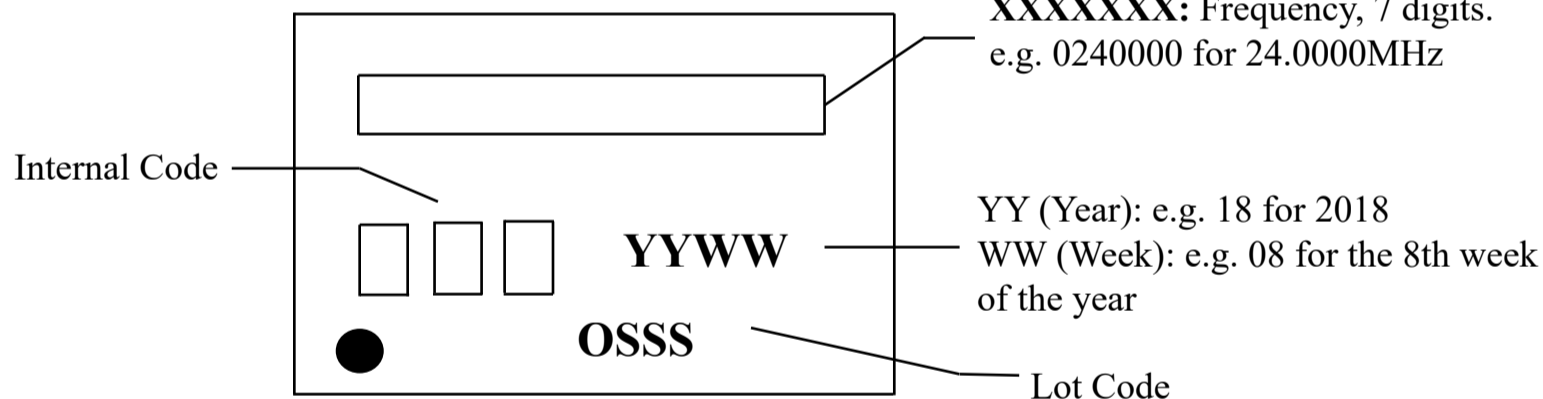

Marking Method: Laser Marking



5101 Hidden Creek Ln Spicewood TX 78669
Phone: 512-371-6159 | Fax: 512-351-8858
For terms and conditions of sales, please visit:
www.abracon.com

REVISED: 07.02.2018

ABRACON IS
ISO9001-2015
CERTIFIED

POWER OPTIMIZED MEMS OSCILLATORS

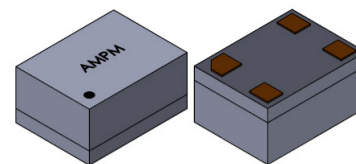

AMPM-SERIES



ESD Sensitive



RoHS/RoHS II Compliant

1.6 x 1.2 x 0.84 mm
2.0 x 1.6 x 0.84 mm
2.5 x 2.0 x 0.84 mm
3.2 x 2.5 x 0.85 mm

MSL = MSL 1

MECHANICAL DIMENSIONS

1.6 x 1.2 mm VFLGA Package Outline

Top View

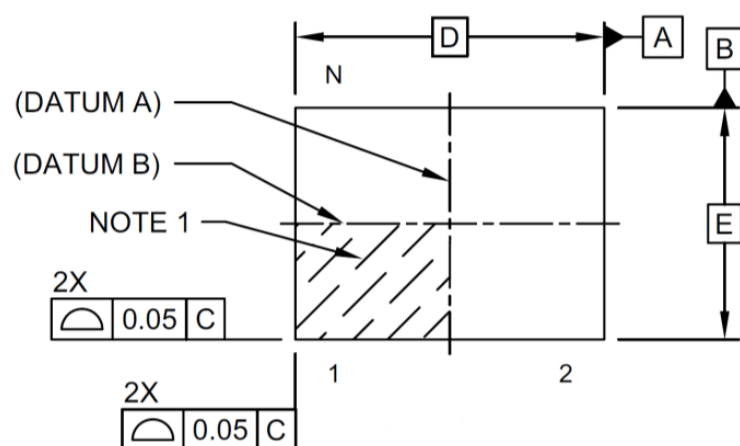

Side View

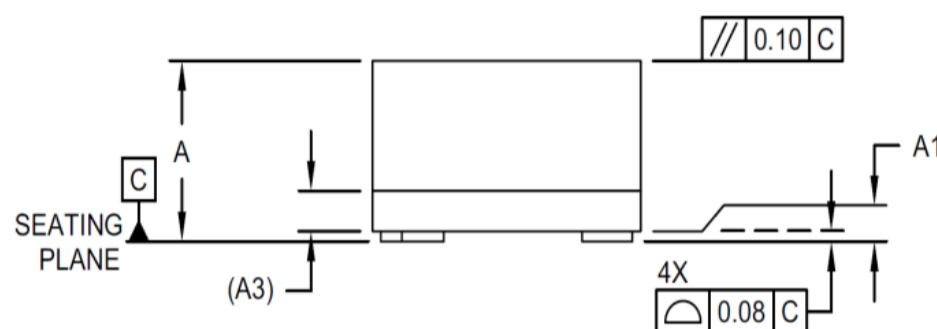

Bottom View

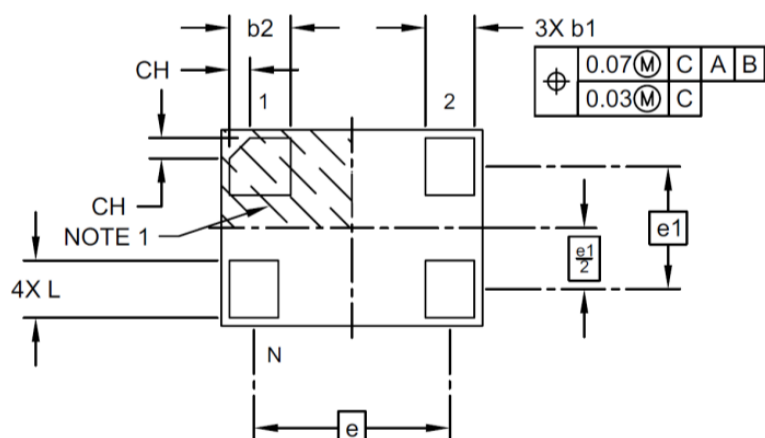

Description	Marker	Dimensions (mm)
Number of Terminals	N	4
Terminal Pitch	e	1.20 BSC
Terminal Pitch	e1	0.75 BSC
Overall Height	A	0.84 ± 0.05
Standoff*	A1	.02
Substrate Thickness (with Terminals)	A3	0.20REF
Overall Length	D	1.60BSC
Overall Width	E	1.20BSC
Terminal Width	b1	0.30 ± 0.05
Terminal Width	b2	0.375 ± 0.05
Terminal Length	L	0.35 ± 0.05
Terminal 1 Index Chamfer	CH	0.125

*Standoff max .05 mm and min 0.00 mm

Dimensioning and tolerance per ASME Y14.5M

BSC: Basic Dimension. Theoretically exact value shown without tolerances

REF: Reference Dimension, usually without tolerance, for information purposes only

POWER OPTIMIZED MEMS OSCILLATORS

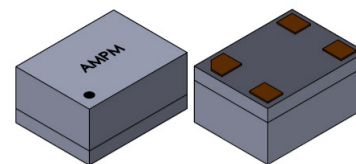

AMPM-SERIES



ESD Sensitive



RoHS/RoHS II Compliant

1.6 x 1.2 x 0.84 mm
2.0 x 1.6 x 0.84 mm
2.5 x 2.0 x 0.84 mm
3.2 x 2.5 x 0.85 mm

MSL = MSL 1

MECHANICAL DIMENSIONS

Recommended Landing Pattern

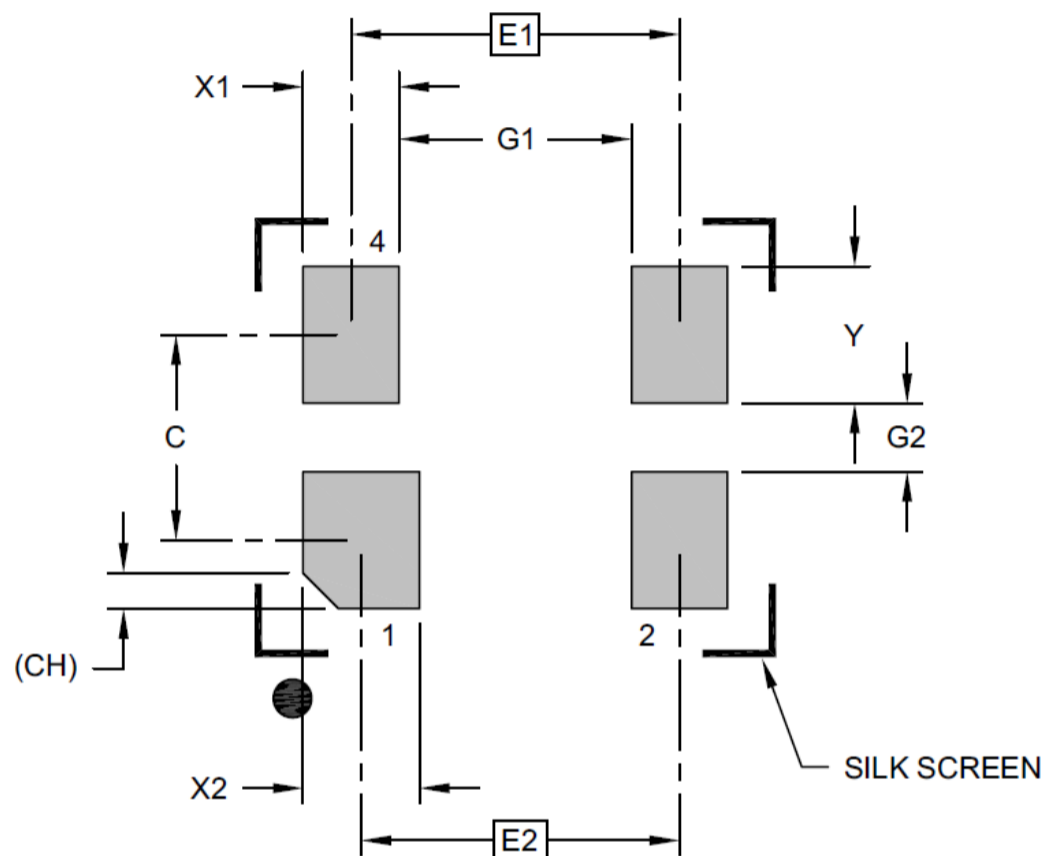

Description	Marker	Max	Typ	Max	Unit
Contact Pitch	E1	1.20 BSC			mm
Contact Pitch	E2	1.16 BSC			
Contact Spacing	C		0.75		
Contact Width	X1			0.35	
Contact Width	X2			0.43	
Contact Pad Length	Y			0.50	
Space Between Contacts	G1	0.85			
Space Between Contacts	G2	0.25			
Contact 1 Index Chamfer	CH	0.13 x 45° REF			

Dimensioning and tolerance per ASME Y14.5M

BSC: Basic Dimension. Theoretically exact value shown without tolerances

REF: Reference Dimension, usually without tolerance, for information purposes only



5101 Hidden Creek Ln Spicewood TX 78669
Phone: 512-371-6159 | Fax: 512-351-8858
For terms and conditions of sales, please visit:
www.abracon.com

REVISED: 07.02.2018

ABRACON IS
ISO9001-2015
CERTIFIED

POWER OPTIMIZED MEMS OSCILLATORS

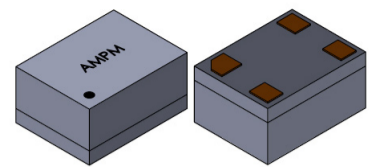

AMPM-SERIES



ESD Sensitive



RoHS/RoHS II Compliant

MSL = MSL 1

1.6 x 1.2 x 0.84 mm
2.0 x 1.6 x 0.84 mm
2.5 x 2.0 x 0.84 mm
3.2 x 2.5 x 0.85 mm

MECHANICAL DIMENSIONS

2.0 x 1.6 mm VFLGA Package Outline

Top View

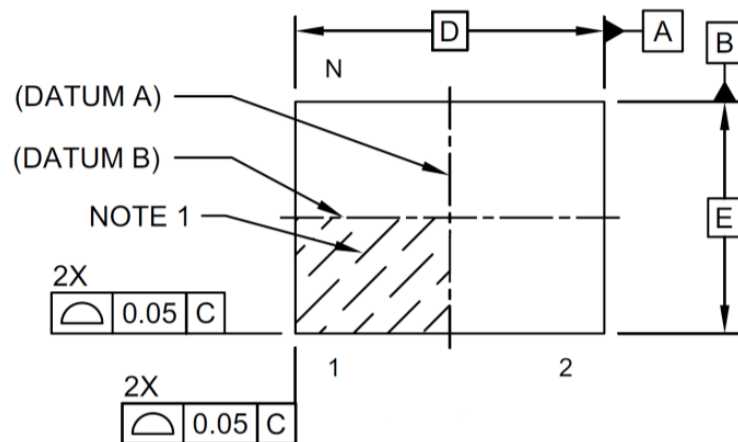

Side View

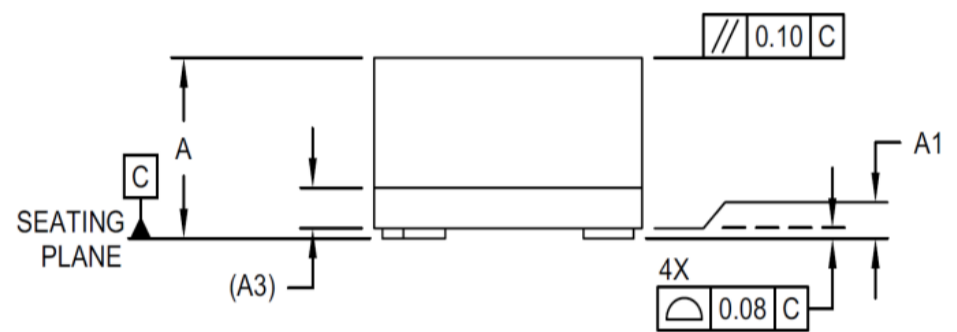

Bottom View



Description	Marker	Dimensions (mm)
Number of Terminals	N	4
Terminal Pitch	e	1.55 BSC
Terminal Pitch	e1	0.95 BSC
Overall Height	A	0.84 ± 0.05
Standoff*	A1	.02
Substrate Thickness (with Terminals)	A3	0.20 REF
Overall Length	D	2.00 BSC
Overall Width	E	1.60 BSC
Terminal Width	b1	0.35 ± 0.05
Terminal Width	b2	0.45 ± 0.05
Terminal Length	L	0.55 ± 0.05
Terminal 1 Index Chamfer	CH	0.15

*Standoff max .05 mm and min 0.00 mm

Dimensioning and tolerance per ASME Y14.5M

BSC: Basic Dimension. Theoretically exact value shown without tolerances

REF: Reference Dimension, usually without tolerance, for information purposes only



5101 Hidden Creek Ln Spicewood TX 78669
Phone: 512-371-6159 | Fax: 512-351-8858
For terms and conditions of sales, please visit:
www.abracon.com

REVISED: 07.02.2018

ABRACON IS
ISO9001-2015
CERTIFIED

POWER OPTIMIZED MEMS OSCILLATORS

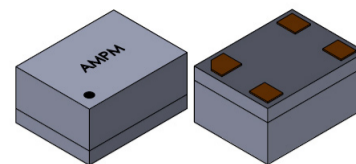

AMPM-SERIES



ESD Sensitive



RoHS/RoHS II Compliant

1.6 x 1.2 x 0.84 mm
2.0 x 1.6 x 0.84 mm
2.5 x 2.0 x 0.84 mm
3.2 x 2.5 x 0.85 mm

MSL = MSL 1

MECHANICAL DIMENSIONS

Recommended Landing Pattern



Description	Marker	Max	Typ	Max	Unit
Contact Pitch	E2	1.55 BSC			mm
Contact Spacing	C		0.95		
Contact Width	X1			0.50	
Contact Width	X2			0.40	
Contact Pad Length	Y			0.70	
Space Between Contacts	G1	1.05			
Space Between Contacts	G2	0.25			
Contact 1 Index Chamfer	CH	0.13 x 45° REF			

Dimensioning and tolerance per ASME Y14.5M

BSC: Basic Dimension. Theoretically exact value shown without tolerances

REF: Reference Dimension, usually without tolerance, for information purposes only



5101 Hidden Creek Ln Spicewood TX 78669
Phone: 512-371-6159 | Fax: 512-351-8858
For terms and conditions of sales, please visit:
www.abracon.com

REVISED: 07.02.2018

ABRACON IS
ISO9001-2015
CERTIFIED

POWER OPTIMIZED MEMS OSCILLATORS

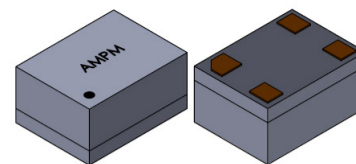

AMPM-SERIES



ESD Sensitive



RoHS/RoHS II Compliant

MSL = MSL 1

1.6 x 1.2 x 0.84 mm
2.0 x 1.6 x 0.84 mm
2.5 x 2.0 x 0.84 mm
3.2 x 2.5 x 0.85 mm

MECHANICAL DIMENSIONS

2.5 x 2.0 mm VLGA Package Outline

Top View

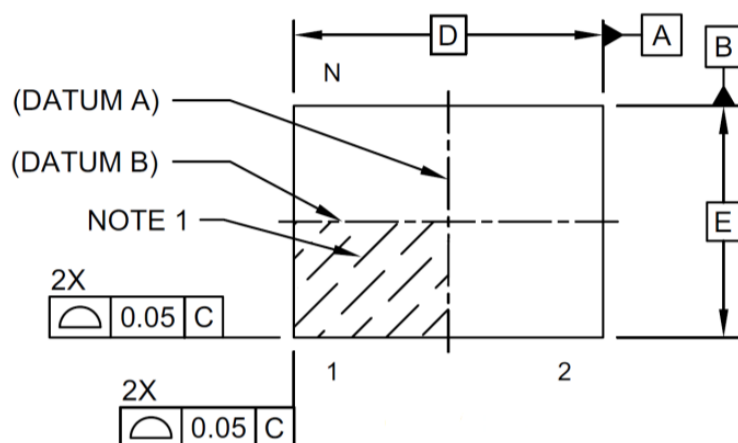

Side View

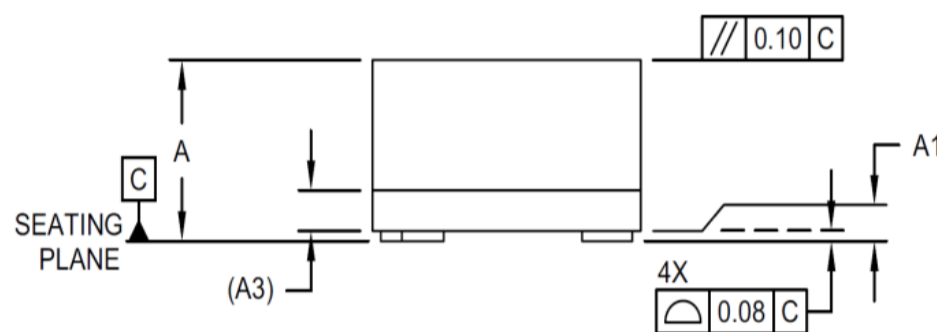

Bottom View

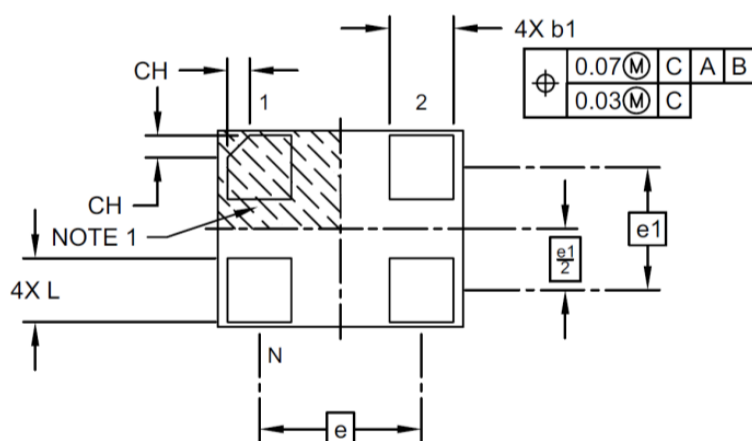

Description	Marker	Dimensions (mm)
Number of Terminals	N	4
Terminal Pitch	e	1.65 BSC
Terminal Pitch	e1	1.25 BSC
Overall Height	A	0.84 ± 0.05
Standoff*	A1	.02
Substrate Thickness (with Terminals)	A3	0.20REF
Overall Length	D	2.50BSC
Overall Width	E	2.00BSC
Terminal Width	b1	0.65 ± 0.05
Terminal Length	L	0.65 ± 0.05
Terminal 1 Index Chamfer	CH	0.225

*Standoff max .05 mm and min 0.00 mm

Dimensioning and tolerance per ASME Y14.5M

BSC: Basic Dimension. Theoretically exact value shown without tolerances

REF: Reference Dimension, usually without tolerance, for information purposes only

POWER OPTIMIZED MEMS OSCILLATORS

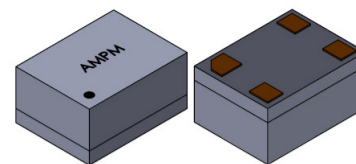

AMPM-SERIES



ESD Sensitive



RoHS/RoHS II Compliant

MSL = MSL 1

1.6 x 1.2 x 0.84 mm
2.0 x 1.6 x 0.84 mm
2.5 x 2.0 x 0.84 mm
3.2 x 2.5 x 0.85 mm

MECHANICAL DIMENSIONS

Recommended Landing Pattern

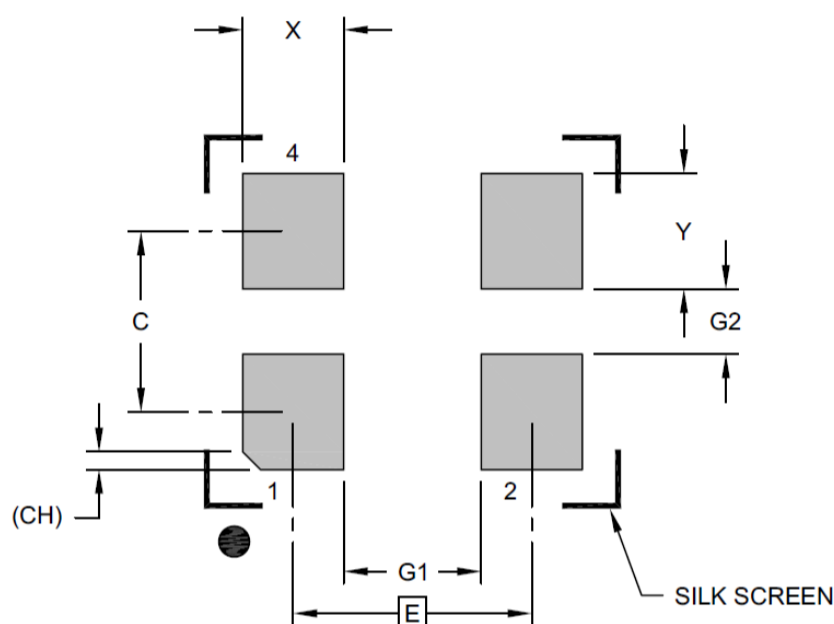

Description	Marker	Max	Typ	Max	Unit
Contact Pitch	E	1.65 BSC			mm
Contact Spacing	C		1.25		
Contact Width	X1			0.70	
Contact Width	X2			0.80	
Contact Pad Length	Y			0.50	
Space Between Contacts	G1	0.95			
Space Between Contacts	G2	0.45			
Contact 1 Index Chamfer	CH	0.13 x 45° REF			

Dimensioning and tolerance per ASME Y14.5M

BSC: Basic Dimension. Theoretically exact value shown without tolerances

REF: Reference Dimension, usually without tolerance, for information purposes only



5101 Hidden Creek Ln Spicewood TX 78669
Phone: 512-371-6159 | Fax: 512-351-8858
For terms and conditions of sales, please visit:
www.abracon.com

REVISED: 07.02.2018

ABRACON IS
ISO9001-2015
CERTIFIED

POWER OPTIMIZED MEMS OSCILLATORS

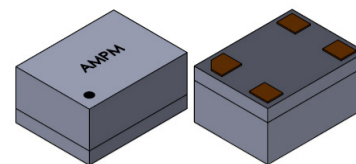

AMPM-SERIES



ESD Sensitive



RoHS/RoHS II Compliant

MSL = MSL 1

1.6 x 1.2 x 0.84 mm
2.0 x 1.6 x 0.84 mm
2.5 x 2.0 x 0.84 mm
3.2 x 2.5 x 0.85 mm

MECHANICAL DIMENSIONS

3.2 x 2.5 mm DFN Package Outline

Top View

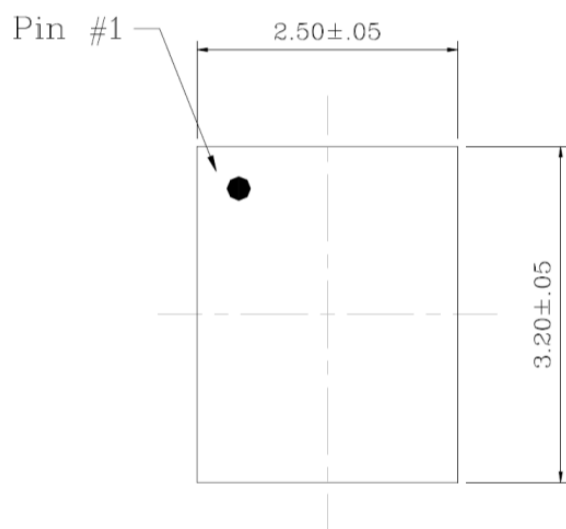

Side View

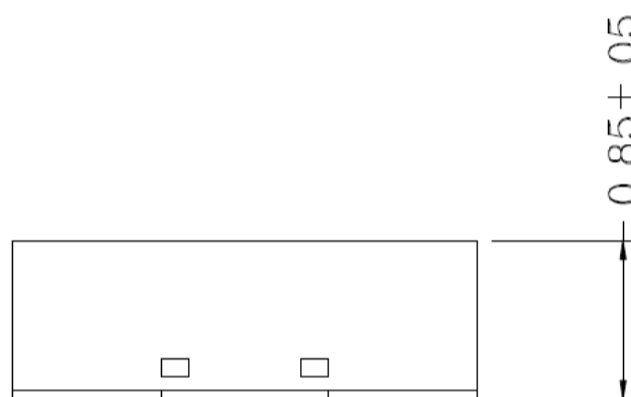

Bottom View

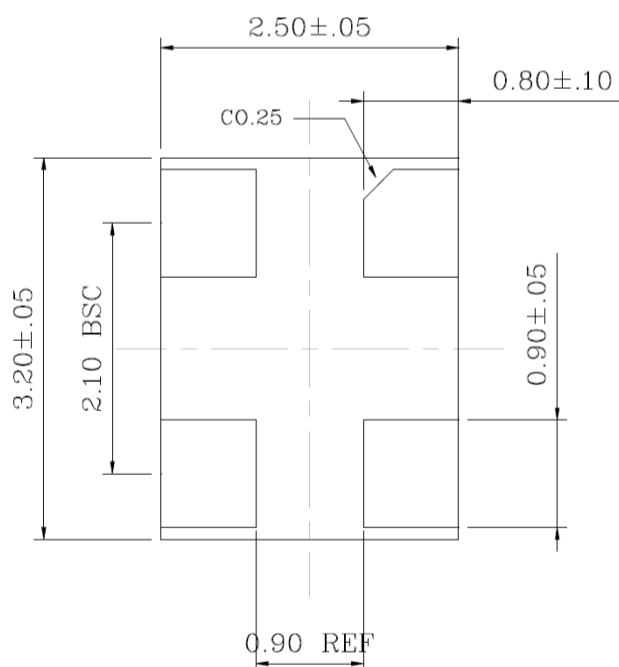

Recommended Landing Pattern

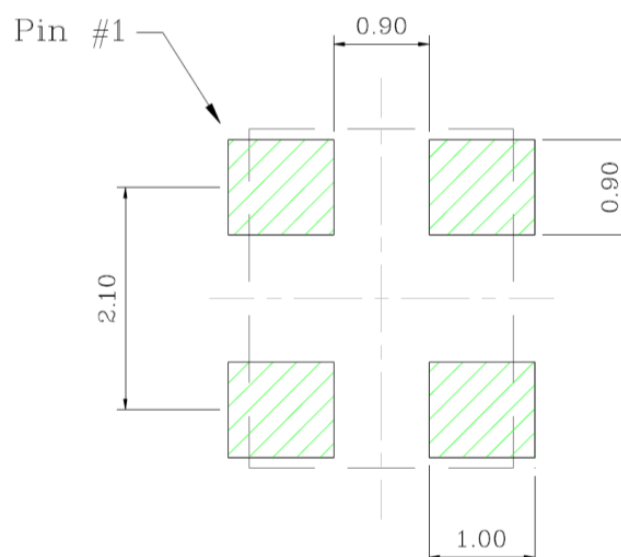

Dimensions : mm

POWER OPTIMIZED MEMS OSCILLATORS

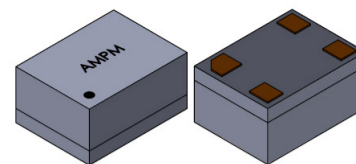

AMPM-SERIES



ESD Sensitive



RoHS/RoHS II Compliant

1.6 x 1.2 x 0.84 mm
2.0 x 1.6 x 0.84 mm
2.5 x 2.0 x 0.84 mm
3.2 x 2.5 x 0.85 mm

MSL = MSL 1

REFLOW PROFILE

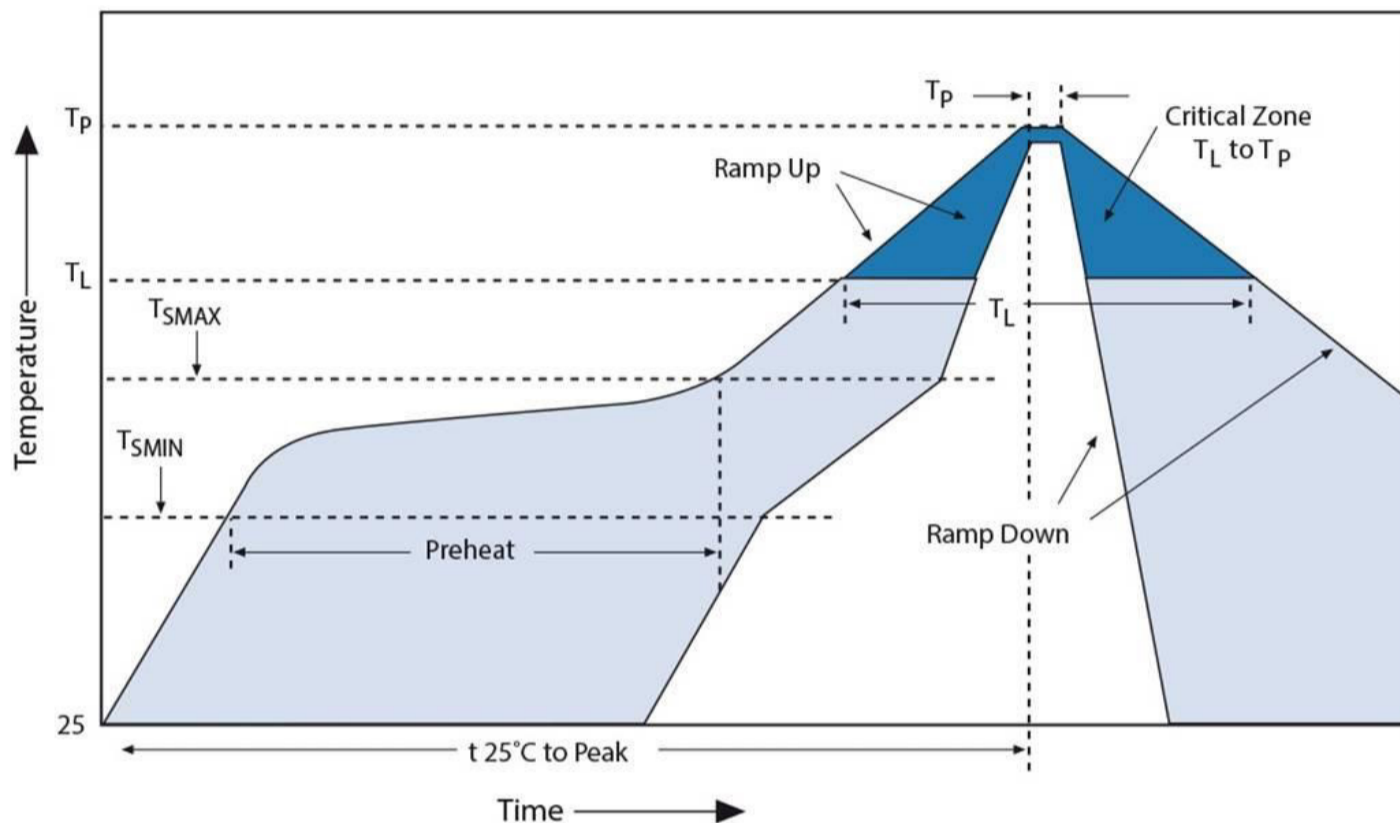

Zone	Description	Temperature	Time
1	Preheat / Soak	$T_{SMIN} \sim T_{SMAX}$ 150°C ~ 200°C	60 ~ 180 sec.
2	Reflow	T_L 217°C	60 ~ 150 sec.
3	Peak heat	T_P 255°C - 260°C	20-40 sec. MAX.

POWER OPTIMIZED MEMS OSCILLATORS

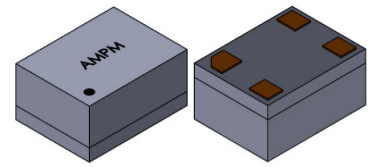

AMPM-SERIES



ESD Sensitive



RoHS/RoHS II Compliant

1.6 x 1.2 x 0.84 mm
2.0 x 1.6 x 0.84 mm
2.5 x 2.0 x 0.84 mm
3.2 x 2.5 x 0.85 mm

MSL = MSL 1

PACKAGING

Bulk MOQ= 100pcs/Bag*
T= 1,000pcs/reel (D=180mm)
T3= 3,000pcs/reel (D=180mm)

Affected Package Size:
1.6 mm x 1.2 mm VFLGA

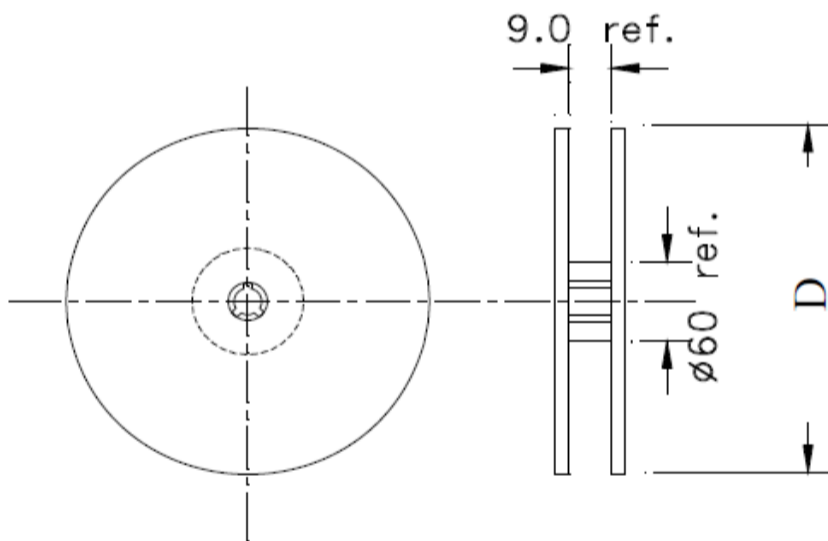
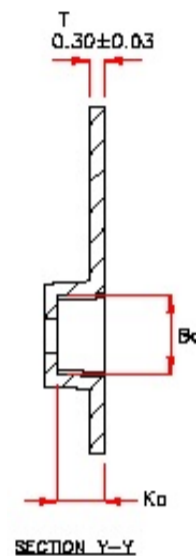
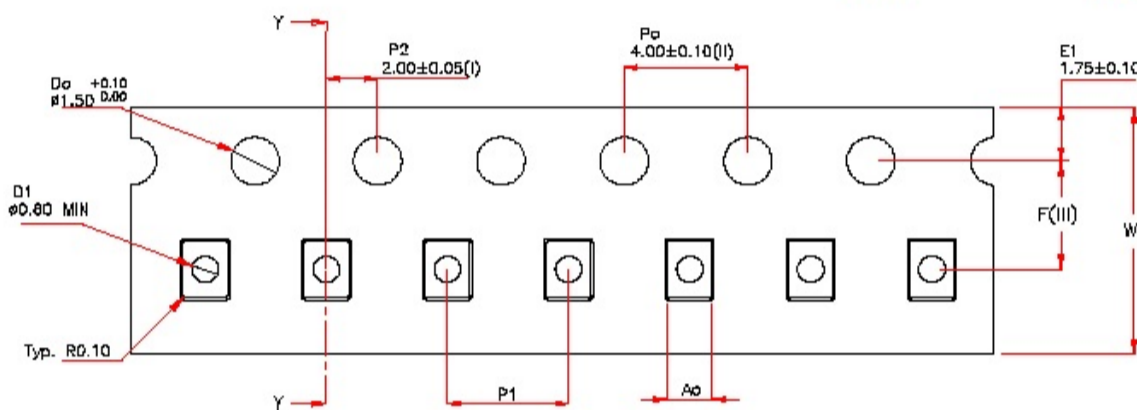

A_0	1.40 ± 0.05
B_0	1.80 ± 0.05
K_0	1.05 ± 0.05
F	3.50 ± 0.05
P_1	4.00 ± 0.10
W	$8.00 +0.30/-0.10$

Dimensions : mm

* For Quick turn-around programmable sample orders less than MOQ represented above:
Due to the immediate availability of stock and the qty of the order, the parts may be delivered as Cut Tape,
Loose parts in Antistatic Bag or in Tube(s).

For orders greater than MOQ and less than 1000pcs:
Due to packaging, the order must be a multiple of MOQ per package size above

For orders greater than 1000pcs:
Bulk is not an option. Please refer to tape and reel packaging.



5101 Hidden Creek Ln Spicewood TX 78669
Phone: 512-371-6159 | Fax: 512-351-8858
For terms and conditions of sales, please visit:
www.abracon.com

REVISED: 07.02.2018

ABRACON IS
ISO9001-2015
CERTIFIED

POWER OPTIMIZED MEMS OSCILLATORS

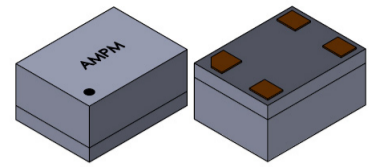

AMPM-SERIES



ESD Sensitive



RoHS/RoHS II Compliant

MSL = MSL 1

1.6 x 1.2 x 0.84 mm
2.0 x 1.6 x 0.84 mm
2.5 x 2.0 x 0.84 mm
3.2 x 2.5 x 0.85 mm

PACKAGING

Bulk MOQ= 100pcs/Bag*
T= 1,000pcs/reel (D=180mm)
T3= 3,000pcs/reel (D=180mm)

Affected Package Sizes:
2.0 mm x 1.6 mm VFLGA

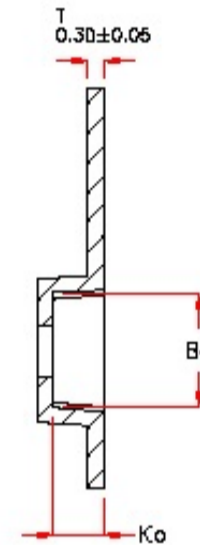
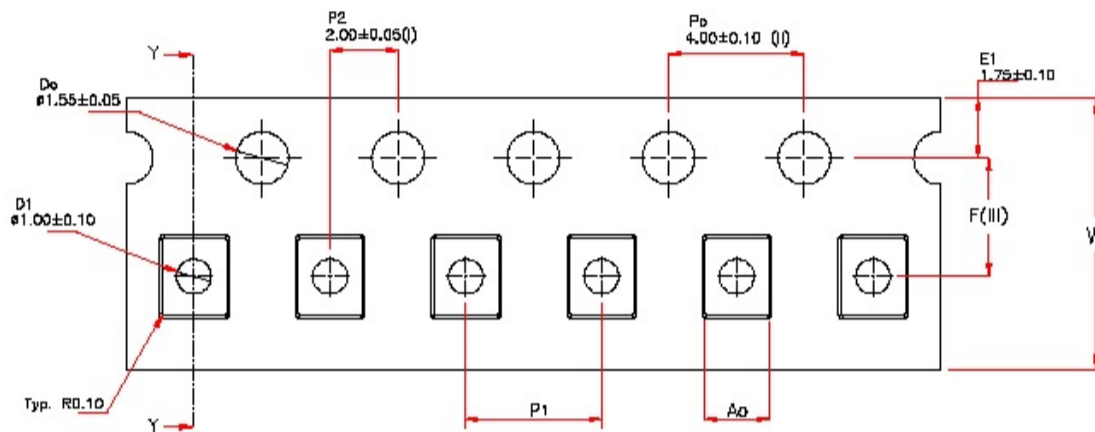

SECTION Y-Y

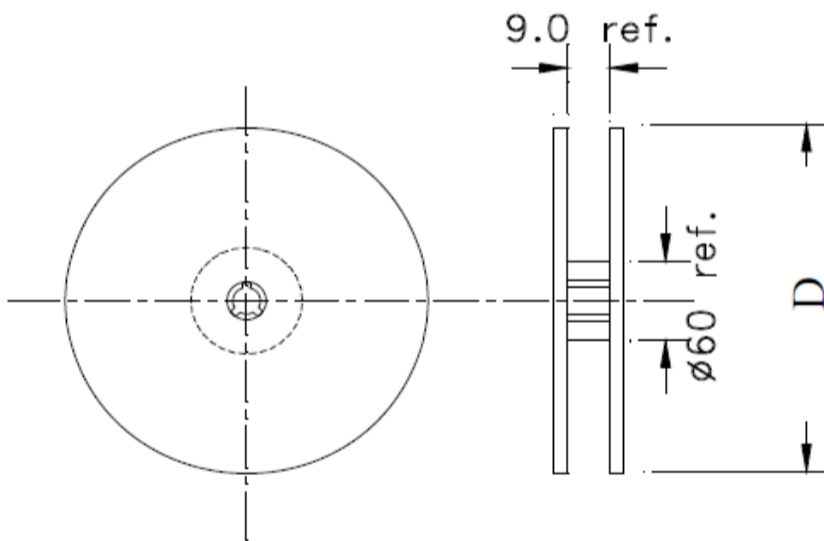

A_0	1.90 ± 0.05
B_0	2.30 ± 0.05
K_0	1.05 ± 0.05
F	3.50 ± 0.05
P_1	4.00 ± 0.10
W	$8.00 +0.30/-0.10$

Dimensions : mm

* For Quick turn-around programmable sample orders less than MOQ represented above:
Due to the immediate availability of stock and the qty of the order, the parts may be delivered as Cut Tape,
Loose parts in Antistatic Bag or in Tube(s).

For orders greater than MOQ and less than 1000pcs:
Due to packaging, the order must be a multiple of MOQ per package size above

For orders greater than 1000pcs:
Bulk is not an option. Please refer to tape and reel packaging.



5101 Hidden Creek Ln Spicewood TX 78669
Phone: 512-371-6159 | Fax: 512-351-8858
For terms and conditions of sales, please visit:
www.abracon.com

REVISED: 07.02.2018

ABRACON IS
ISO9001-2015
CERTIFIED

POWER OPTIMIZED MEMS OSCILLATORS

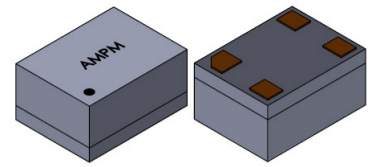

AMPM-SERIES



ESD Sensitive



RoHS/RoHS II Compliant

MSL = MSL 1

1.6 x 1.2 x 0.84 mm
2.0 x 1.6 x 0.84 mm
2.5 x 2.0 x 0.84 mm
3.2 x 2.5 x 0.85 mm

PACKAGING

Bulk MOQ= 140pcs/Tube*
T= 1,000pcs/reel (D=180mm)
T3= 3,000pcs/reel (D=180mm)

Affected Package Sizes:
2.5 mm x 2.0 mm VLGA

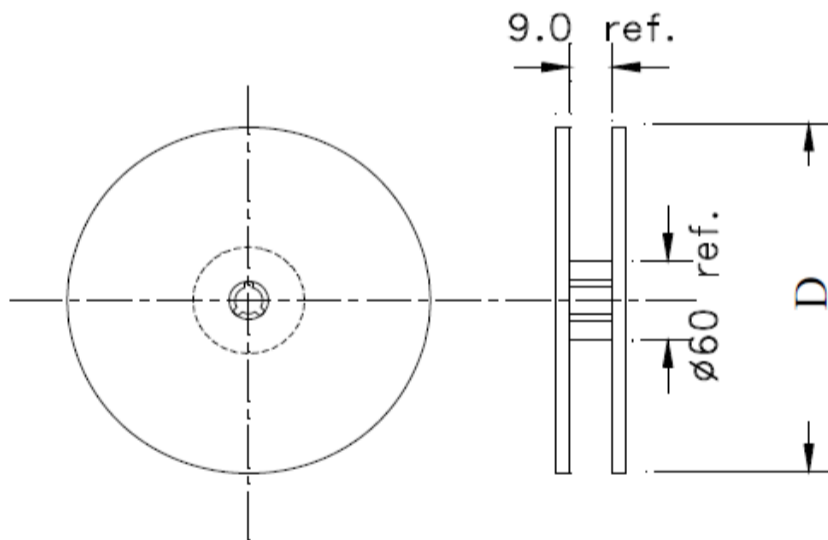
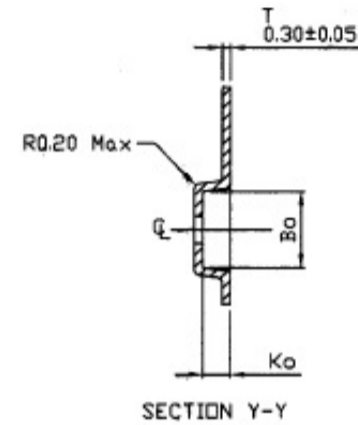
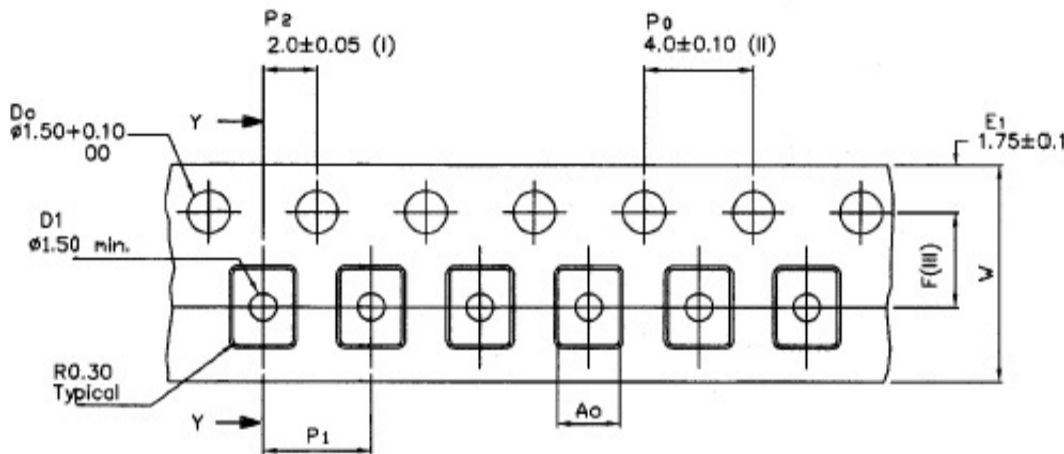

A ₀	2.25 ± 0.05
B ₀	2.80 ± 0.05
K ₀	1.10 ± 0.05
F	3.50 ± 0.05
P ₁	4.00 ± 0.10
W	8.00 +0.30/-0.10

Dimensions : mm

* For Quick turn-around programmable sample orders less than MOQ represented above:
Due to the immediate availability of stock and the qty of the order, the parts may be delivered as Cut Tape,
Loose parts in Antistatic Bag or in Tube(s).

For orders greater than MOQ and less than 1000pcs:
Due to packaging, the order must be a multiple of MOQ per package size above

For orders greater than 1000pcs:
Bulk is not an option. Please refer to tape and reel packaging.



5101 Hidden Creek Ln Spicewood TX 78669
Phone: 512-371-6159 | Fax: 512-351-8858
For terms and conditions of sales, please visit:
www.abracon.com

REVISED: 07.02.2018

ABRACON IS
ISO9001-2015
CERTIFIED

POWER OPTIMIZED MEMS OSCILLATORS

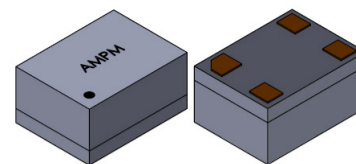

AMPM-SERIES



ESD Sensitive



RoHS/RoHS II Compliant

MSL = MSL 1

1.6 x 1.2 x 0.84 mm
2.0 x 1.6 x 0.84 mm
2.5 x 2.0 x 0.84 mm
3.2 x 2.5 x 0.85 mm

PACKAGING

Bulk MOQ= 110pcs/Tube*
T= 1,000pcs/reel (D=180mm)
T3= 3,000pcs/reel (D=180mm)

Affected Package Sizes:
3.2 mm x 2.5 mm DFN

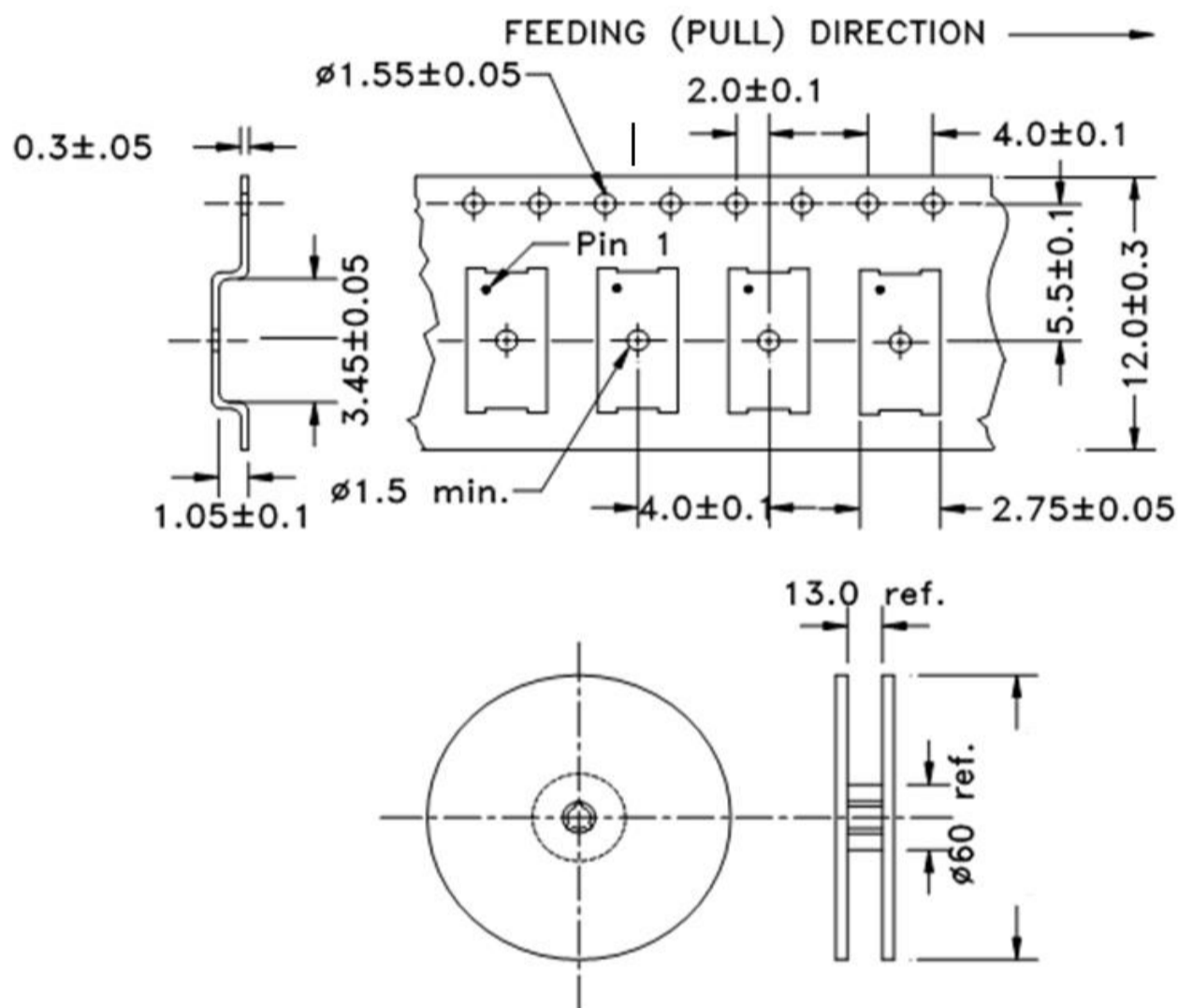

Dimensions : mm

* For Quick turn-around programmable sample orders less than MOQ represented above:
Due to the immediate availability of stock and the qty of the order, the parts may be delivered as Cut Tape,
Loose parts in Antistatic Bag or in Tube(s).

For orders greater than MOQ and less than 1000pcs:
Due to packaging, the order must be a multiple of MOQ per package size above

For orders greater than 1000pcs:
Bulk is not an option. Please refer to tape and reel packaging.



5101 Hidden Creek Ln Spicewood TX 78669
Phone: 512-371-6159 | Fax: 512-351-8858
For terms and conditions of sales, please visit:
www.abracon.com

REVISED: 07.02.2018

ABRACON IS
ISO9001-2015
CERTIFIED