

MCT0177A0W240320PMLIPS	240 x 320	SPI and Parallel Interface	TFT Module
<b>Specification</b>			
Version: 1		Date: 16/04/2018	
<b>Revision</b>			
1	13/03/2017	First issue.	

Display Features			
Display Size	1.77"		
Resolution	240 x 320		
VGA Size	QVGA		
Orientation	Portrait		
Appearance	RGB		
Logic Voltage	3.3V		
Interface	SPI and Parallel		
Brightness	450 cd/m <sup>2</sup>		
Touchscreen	N/A		
Module Size	1.65 mm		
Operating Temperature	-20°C ~ +70°C		Box Quantity
Pinout	45 - Way FFC		Weight / Display
		---	---



**RoHS**  
compliant

\* - For full design functionality, please use this specification in conjunction with the ST7789S specification. (Provided Separately)

Display Accessories	
Part Number	Description
MPBV5	50 Way FFC to cable and wires. Driven by any driver board that can be wired to a 1mm pitch SHDR-50V-S-B receptacle.
LEDV3	Constant current LED back light driver.

Optional Variants	
Appearances	Voltage



<b>4. LCD Optical Characteristics .....</b>	<b>8</b>
4.1 Optical specification .....	8
4.2 Measuring Condition.....	9
4.3 Measuring Equipment.....	9
<b>5. Electrical Characteristics.....</b>	<b>10</b>
5.1 Absolute Maximum Rating (Ta=25 VSS=0V).....	10
5.2 DC Electrical Characteristics.....	11
5.3 LED Backlight Characteristics .....	11
<b>6. AC Characteristic .....</b>	<b>13</b>
6.1 Display Parallel 8/16-bit Interface Timing Characteristics (8080 system).....	13
6.2 Display Serial Interface Timing Characteristics (3-line SPI system).....	15
6.3 Display Serial Interface Timing Characteristics (4-line SPI system).....	16
6.4 Parallel RGB Interface Timing Characteristics.....	17
6.5 Reset Timing Characteristics .....	18
<b>7. LCD Module Out-Going Quality Level .....</b>	<b>20</b>
7.1 VISUAL & FUNCTION INSPECTION STANDARD .....	21
7.1.1 Inspection conditions .....	21
7.1.2 Definition .....	21
7.1.3 Sampling Plan .....	21
7.1.4 Criteria (Visual).....	22
<b>8. Reliability Test Result .....</b>	<b>26</b>
8.1 Condition .....	26
<b>9. Cautions and Handling Precautions .....</b>	<b>27</b>
9.1 Handling and Operating the Module .....	27
9.2 Storage and Transportation.....	27
<b>10. Packing.....</b>	<b>28</b>

**\* Description**

This is a color active matrix TFT (Thin Film Transistor) LCD (liquid crystal display) that uses amorphous silicon TFT as a switching device. This model is composed of a Transmissive type TFT-LCD Panel, driver circuit, back-light unit. The resolution of a 1.77" TFT-LCD contains 240x320 pixels, and can display up to 65K colors.

**\* Features**

- Low Input Voltage: VCC:3.3V(TYP);IOVCC:2.8-3.3V
- Display Colors of TFT LCD: 65K colors
- Interface: 8/9/16/18Bit MCU;
  - 3/4SPI+16/18Bit RGB
  - 3-line/4-line Serial Interface



General Information Items	Specification	Unit	Note
	Main Panel		
Display area(AA)	26.64(H)*35.52(V) (1.77inch)	mm	-
Driver element	TFT active matrix	-	-
Display colors	65/262K	colors	-
Number of pixels	240(RGB)*320	dots	-
Pixel arrangement	RGB vertical stripe	-	-
Pixel pitch	0.111(H)*0.111(V)	mm	-
Viewing angle	Free	o'clock	-
Controller IC	ST7789S	-	-
Display mode	Transmissive/Normally black	-	-
Operating temperature	-20~+70	°C	-
Storage temperature	-30~+80	°C	-

**\* Mechanical Information**

Item		Min.	Typ.	Max.	Unit	Note
Module size	Horizontal(H)		34.7		mm	-
	Vertical(V)		46.7		mm	-
	Depth(D)		2.65		mm	-
Weight			TBD		g	-

DESIGN • MANUFACTURE • SUPPLY

**1. Block Diagram**



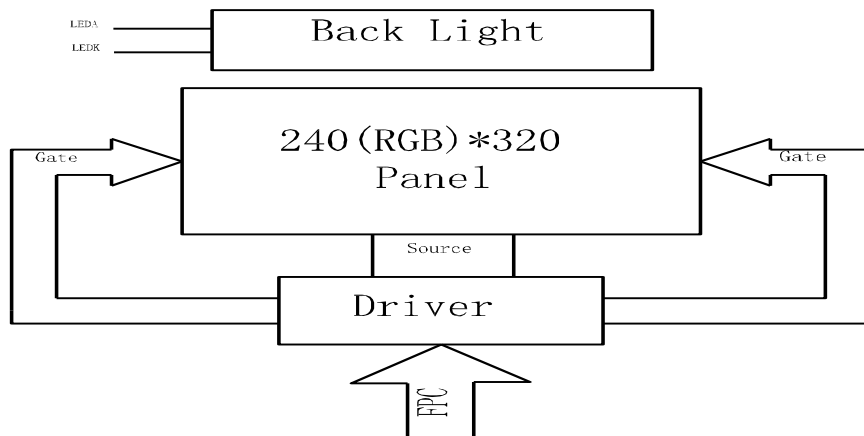

MIDAS  
DISPLAYS

---

DESIGN • MANUFACTURE • SUPPLY

## 2. Outline dimension



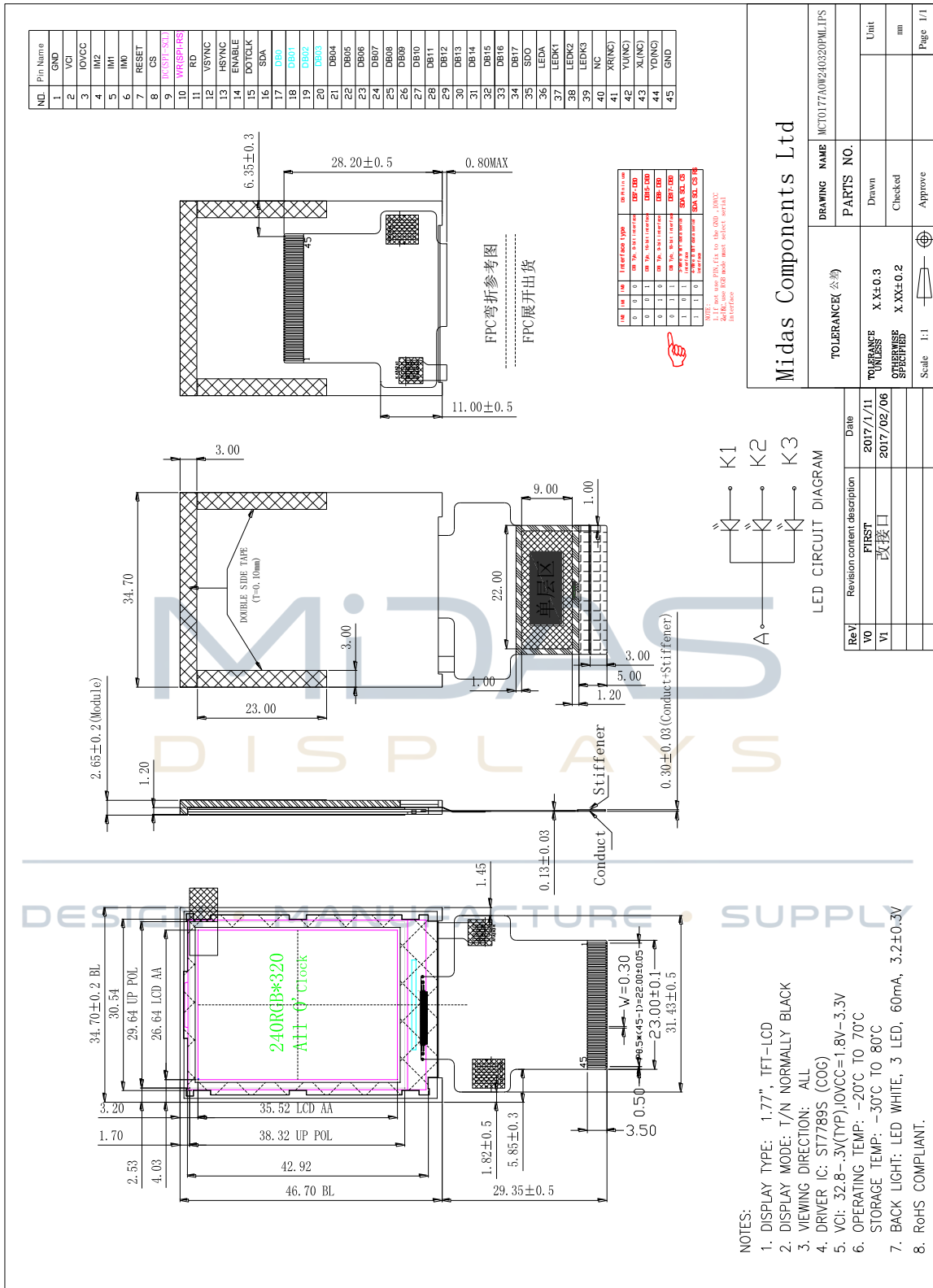

### 3. Input terminal Pin Assignment

NO.	SYMBOL	DISCRIPTION	I/O
1	GND	Ground.	P
2	VCI/VCC	Supply voltage(3.3V).	P

3	IOVCC	Supply voltage(1.65-3.3V).	P
4	IM2	Interface selecting signal.	I
5	IM1		I
6	IM0		I
7	RESET	This signal will reset the device and must be applied to properly initialize the chip.	I
8	CS	Chip select input pin ("Low" enable). fix this pin at VCI or GND when not in use.	I
9	DC(SPI-SCL)	-Display data/command selection pin in parallel interface. -This pin is used to be serial interface clock. DC='1': display data or parameter. DC='0': command data. -If not used, please fix this pin at VDDI or DGND.	I
10	WR(SPI-RS)	-Write enable in MCU parallel interface. - Display data/command selection pin in 4-line serial interface. - Second Data lane in 2 data lane serial interface. -If not used, please fix this pin at VDDI or DGND.	I
11	RD	Serves as a read signal and MCU read data at the rising edge. fix this pin at VCI or GND when not in use.	I
12	VSYNC	Frame synchronous signal. Low active. Connect to I GND when DPI is not selected.	I
13	HSYNC	Line synchronous signal. Low active. Connect to GND when DPI is not selected.	I
14	ENABLE	Data enable signal in DPI operation. Low: Select (Accessible) High: Not select (Inaccessible) Connect to GND when DPI is not selected.	I
15	DOTCLK	Pixel clock signal. The data input timing is set on the rising edge. Connect to GND when DPI is not selected.	I
16	SDA	Serial data input/output pin in DBI Type C operation.	I
17~34	DB0~DB17	Data bus. Connect to GND when is not used.	P
35	SDO	This pin is enabled when SDOE=1 and DBI Type C is used. With this setting, SDA can be used as an input pin and SDO pin can be used as an output pin without bidirectional bus to execute serial communication. If not used please open.	O
36	LEDA	Anode pin of backlight.	P
37	LEDK1	Cathode pin of backlight.	P



38	LEDK2	Cathode pin of backlight.	P
39	LEDK3	Cathode pin of backlight.	P
40	NC	NC	
41	XR(NC)	Touch panel Right Glass Terminal	A/D
42	YU(NC)	Touch panel Top Film Terminal	A/D
43	XL(NC)	Touch panel LIFT Glass Terminal	A/D
44	YD(NC)	Touch panel Bottom Film Terminal	A/D
45	GND	Ground.	P



DESIGN • MANUFACTURE • SUPPLY

## 4. LCD Optical Characteristics

### 4.1 Optical specification

Item	Symbol	Condition	Min.	Typ.	Max.	Unit.	Note
Contrast Ratio	CR	$\Theta=0$	500	600			
Response time	Rising	Normal viewing angle	--	20	45	msec	
	Falling		--	35	50		
Color gamut	S(%)		--	49.3	--	%	
Color Filter Chromacity	White	$W_X$	0.260	0.300	0.340		
		$W_Y$	0.280	0.320	0.360		
	Red	$R_X$	0.609	0.629	0.649		
		$R_Y$	0.307	0.327	0.347		



	Green	$G_X$		0.292	0.312	0.332			
		$G_Y$		0.535	0.555	0.575			
	Blue	$B_X$		0.144	0.164	0.184			
		$B_Y$		0.149	0.169	0.189			
Viewing angle	Hor.	$\Theta_L$	CR>10	60	85	--			
		$\Theta_R$		60	85	--			
	Ver.	$\Theta_U$		60	85	--			
		$\Theta_D$		60	85	--			
Option View Direction		Free							

## 4.2 Measuring Condition

- Measuring surrounding: dark room
- Ambient temperature:  $25\pm 2^\circ\text{C}$
- 15min. warm-up time.

## 4.3 Measuring Equipment





---

DESIGN • MANUFACTURE • SUPPLY

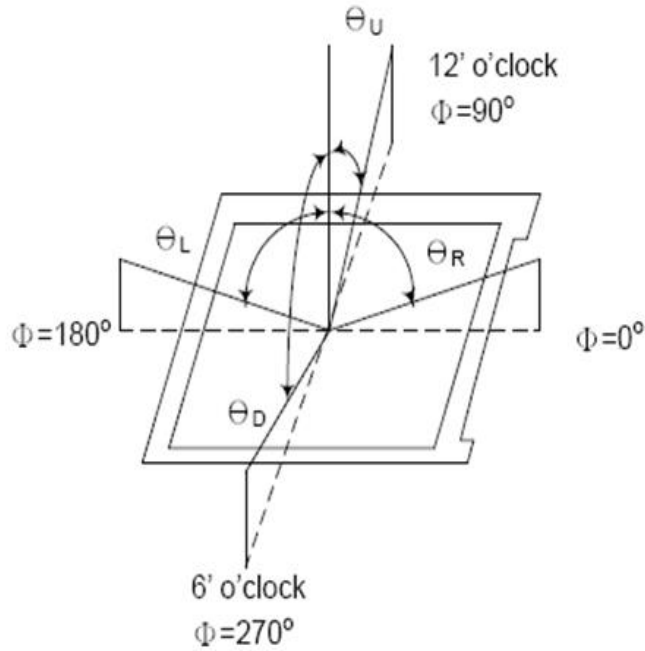

- FPM520 of Westar Display technologies, INC., which utilized SR-3 for Chromaticity and BM-5A for other optical characteristics.

Note (1) Definition of Viewing Angle:



Note (2) Definition of Contrast Ratio (CR) :  
measured at the center point of panel

$$CR = \frac{\text{Luminance with all pixels white}}{\text{Luminance with all pixels black}}$$

## 5. Electrical Characteristics

### 5.1 Absolute Maximum Rating (Ta=25 VSS=0V)

Characteristics	Symbol	Min.	Max.	Unit
Digital Supply Voltage	VDD	-0.3	4.6	V
Digital interface supply Voltage	VDDIO	-0.3	4.6	V



Operating temperature	T <sub>OP</sub>	-20	+70	°C
Storage temperature	T <sub>ST</sub>	-30	+80	°C

NOTE: If the absolute maximum rating of even is one of the above parameters is exceeded even momentarily, the quality of the product may be degraded. Absolute maximum ratings, therefore, specify the values exceeding which the product may be physically damaged. Be sure to use the product within the range of the absolute maximum ratings.

## 5.2 DC Electrical Characteristics

Characteristics	Symbol	Min.	Typ.	Max.	Unit	Note
Digital Supply Voltage	VDD	2.4	2.8	3.3	V	
Digital interface supply Voltage	VDDIO	1.65	1.8	3.3	V	
Normal mode Current consumption	I <sub>DD</sub>	--	7	--	mA	
Level input voltage	V <sub>IH</sub>	0.7V <sub>DDIO</sub>		V <sub>DDIO</sub>	V	
	V <sub>IL</sub>	GND		0.3V <sub>DDIO</sub>	V	
Level output voltage	V <sub>OH</sub>	0.8V <sub>DDIO</sub>		V <sub>DDIO</sub>	V	
	V <sub>OL</sub>	GND		0.2V <sub>DDIO</sub>	V	

## 5.3 LED Backlight Characteristics

The back-light system is edge-lighting type with 3 chips White LED

Item	Symbol	Min.	Typ.	Max.	Unit	Note
Forward Current	I <sub>F</sub>	45	60	--	mA	
Forward Voltage	V <sub>F</sub>	--	3.2	--	V	
LCM Luminance	L <sub>v</sub>	400	450	--	cd/m <sup>2</sup>	Note3
LED life time	Hr	50000	--	--	Hour	Note1,2
Uniformity	AVg	80	--	--	%	Note3



Note (1) LED life time (Hr) can be defined as the time in which it continues to operate under the condition:

$T_a=25\pm 3\text{ }^\circ\text{C}$ , typical IL value indicated in the above table until the brightness becomes less than 50%.

Note (2) The “LED life time” is defined as the module brightness decrease to 50% original brightness at  $T_a=25\text{ }^\circ\text{C}$  and  $I_L=60\text{mA}$ . The LED lifetime could be decreased if operating  $I_L$  is larger than 60mA. The constant current driving method is suggested.

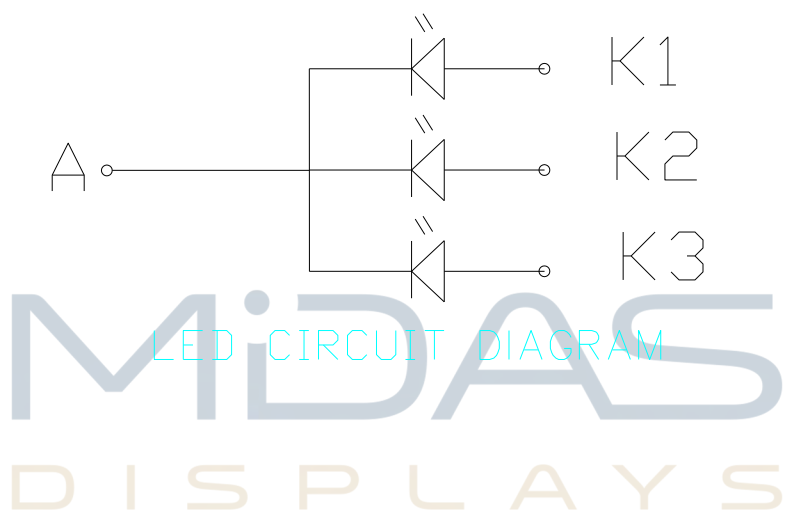

---

NOTE 3: Luminance Uniformity of these 9 points is defined as below: • SUPPLY



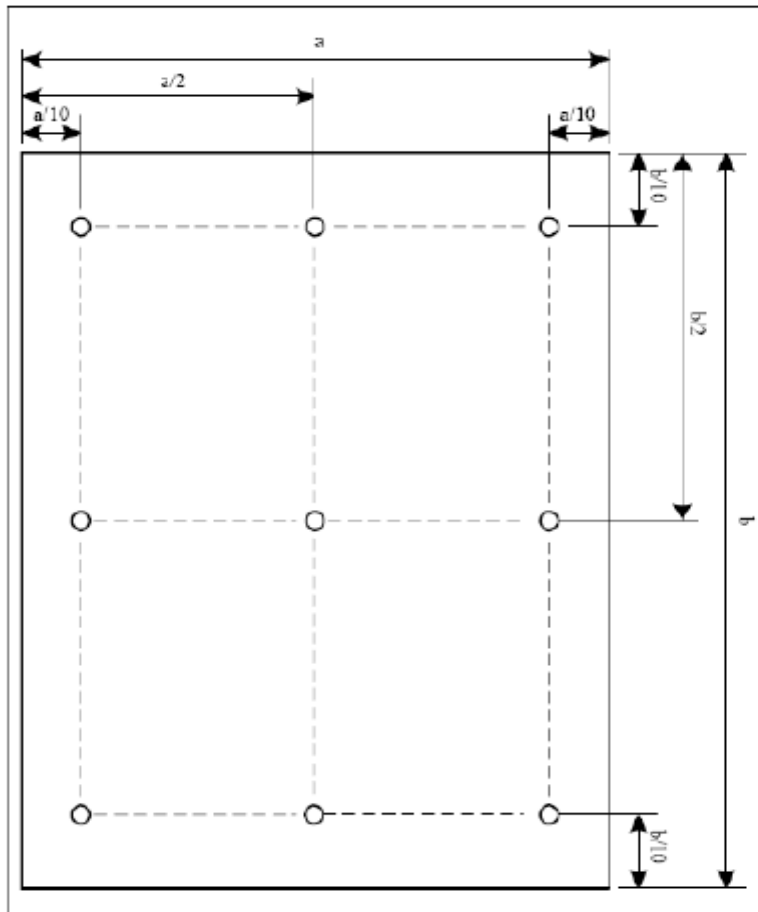

$$\text{Uniformity} = \frac{\text{minimum luminance in 9 points (1-9)}}{\text{maximum luminance in 9 points (1-9)}}$$

---

$$\text{Luminance} = \frac{\text{Total Luminance of 9 points}}{9}$$

## 6. AC Characteristic

### 6.1 Display Parallel 8/16-bit Interface Timing Characteristics (8080 system)



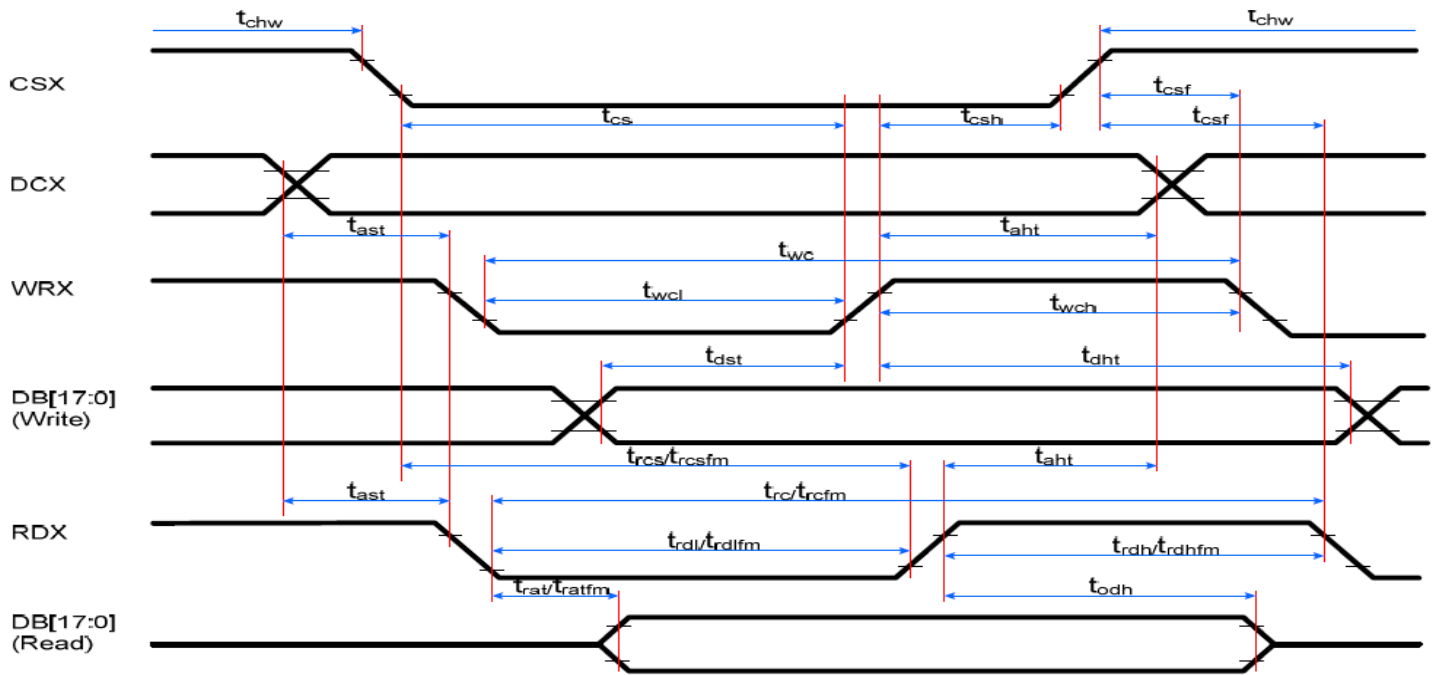

Signal	Symbol	Parameter	min	max	Unit	Description
DCX	tast	Address setup time	0	-	ns	
	taht	Address hold time (Write/Read)	10	-	ns	
CSX	tchw	CSX "H" pulse width	0	-	ns	
	tcs	Chip Select setup time (Write)	15	-	ns	
	trcs	Chip Select setup time (Read ID)	45	-	ns	
	trcsfm	Chip Select setup time (Read FM)	355	-	ns	
WRX	tcsf	Chip Select Wait time (Write/Read)	10	-	ns	
	twc	Write cycle	66	-	ns	
	twrh	Write Control pulse H duration	15	-	ns	
RDX (FM)	twrl	Write Control pulse L duration	15	-	ns	
	trcfm	Read Cycle (FM)	450	-	ns	
RDX (ID)	trdhfm	Read Control H duration (FM)	90	-	ns	
	trdlfm	Read Control L duration (FM)	355	-	ns	
	trc	Read cycle (ID)	160	-	ns	
D[17:0], D[15:0], D[8:0], D[7:0]	trdh	Read Control pulse H duration	90	-	ns	For maximum CL=30pF For minimum CL=8pF
	trdl	Read Control pulse L duration	45	-	ns	
	tdst	Write data setup time	10	-	ns	
	tdht	Write data hold time	10	-	ns	
	trat	Read access time	-	40	ns	
	tratfm	Read access time	-	340	ns	
	trod	Read output disable time	20	80	ns	

Note:  $T_a = -30$  to  $70$  °C,  $IOVCC=1.65V$  to  $2.8V$ ,  $VCI=2.6V$  to  $3.3V$ ,  $GND=0V$

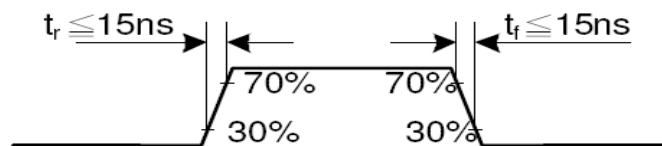

CSX timings :

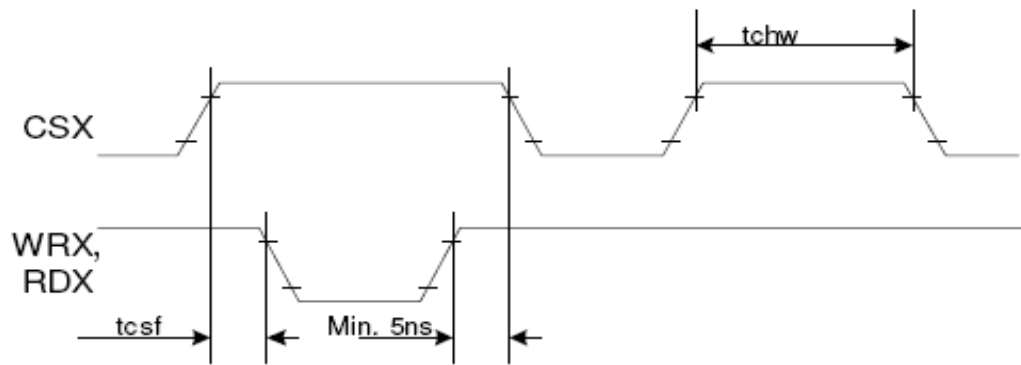

*Note: Logic high and low levels are specified as 30% and 70% of IOVCC for Input signals.*

Write to read or read to write timings:

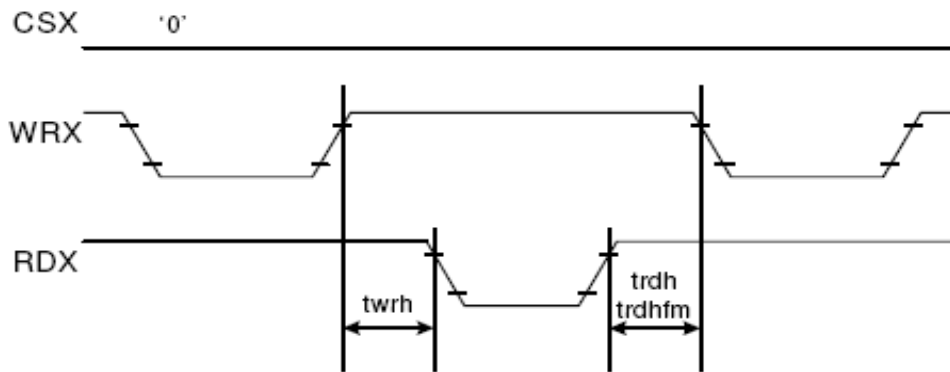

*Note: Logic high and low levels are specified as 30% and 70% of IOVCC for Input signals.*

## 6.2 Display Serial Interface Timing Characteristics (3-line SPI system)



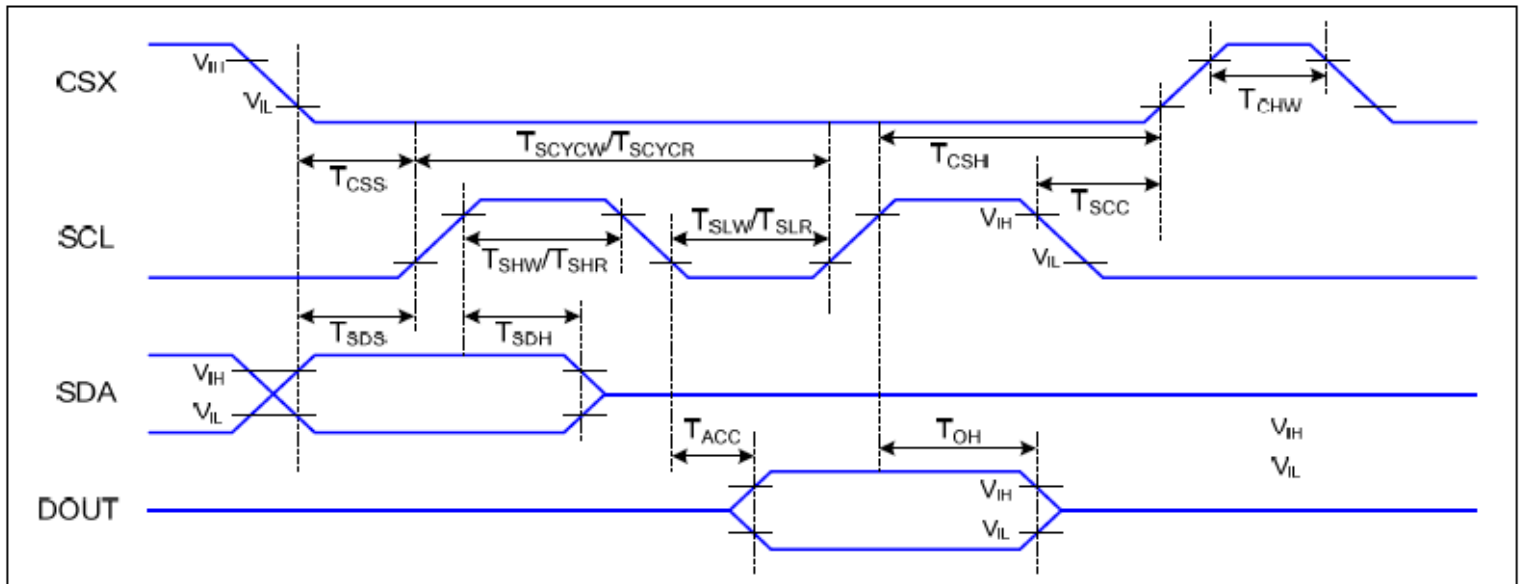

VDDI=1.65 to 3.3V, VDD=2.4 to 3.3V, AGND=DGND=0V, Ta=-30 to 70 °C

Signal	Symbol	Parameter	Min	Max	Unit	Description
CSX	$T_{CSS}$	Chip select setup time (write)	15		ns	
	$T_{CSH}$	Chip select hold time (write)	15		ns	
	$T_{CSS}$	Chip select setup time (read)	60		ns	
	$T_{SCC}$	Chip select hold time (read)	65		ns	
	$T_{CHW}$	Chip select "H" pulse width	40		ns	
SCL	$T_{SCYCW}$	Serial clock cycle (Write)	66		ns	
	$T_{SHW}$	SCL "H" pulse width (Write)	15		ns	
	$T_{SLW}$	SCL "L" pulse width (Write)	15		ns	
	$T_{SCYCR}$	Serial clock cycle (Read)	150		ns	
	$T_{SHR}$	SCL "H" pulse width (Read)	60		ns	
	$T_{SLR}$	SCL "L" pulse width (Read)	60		ns	
SDA (DIN)	$T_{SDS}$	Data setup time	10		ns	
	$T_{SDH}$	Data hold time	10		ns	
DOUT	$T_{ACC}$	Access time	10	50	ns	For maximum CL=30pF
	$T_{OH}$	Output disable time	15	50	ns	For minimum CL=8pF

### 6.3 Display Serial Interface Timing Characteristics (4-line SPI system)

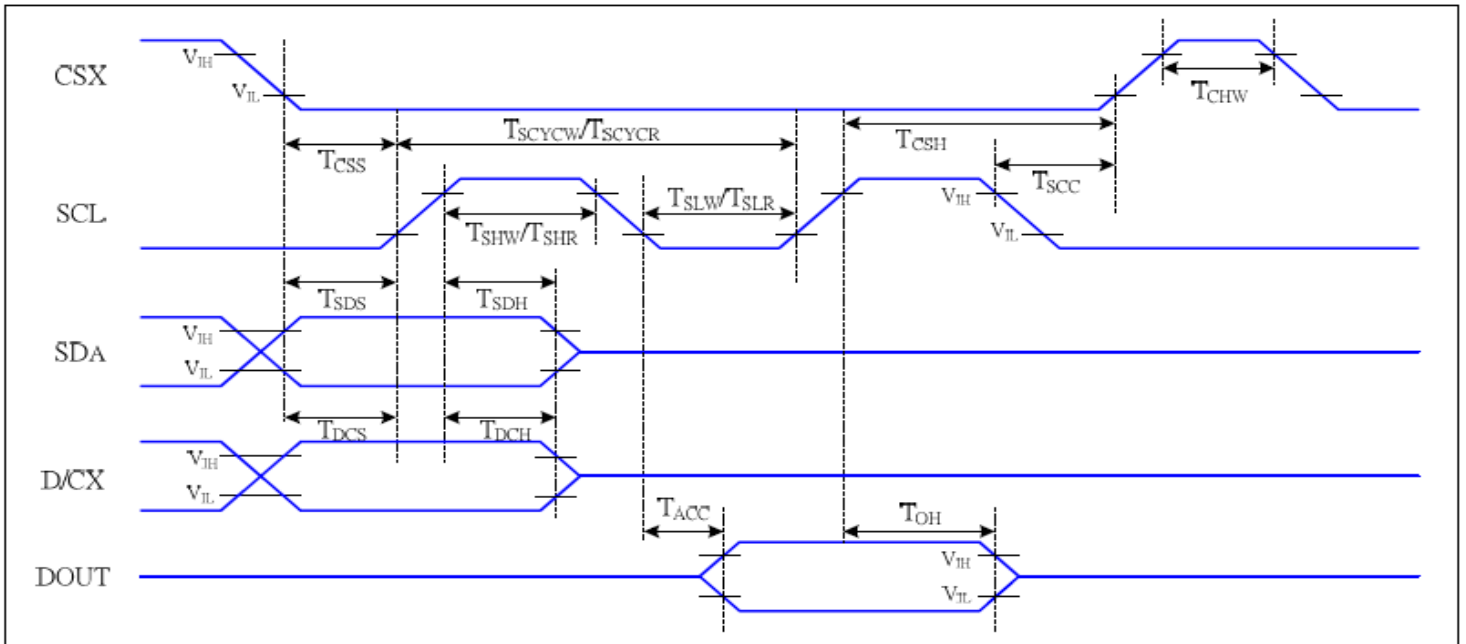

VDDI=1.65 to 3.3V, VDD=2.4 to 3.3V, AGND=DGND=0V, Ta=-30 to 70 °C

Signal	Symbol	Parameter	MIN	MAX	Unit	Description
CSX	T <sub>CSS</sub>	Chip select setup time (write)	15		ns	
	T <sub>CSH</sub>	Chip select hold time (write)	15		ns	
	T <sub>CSS</sub>	Chip select setup time (read)	60		ns	
	T <sub>SCC</sub>	Chip select hold time (read)	65		ns	
	T <sub>CHW</sub>	Chip select "H" pulse width	40		ns	
SCL	T <sub>SCYCW</sub>	Serial clock cycle (Write)	66		ns	-write command & data ram
	T <sub>SHW</sub>	SCL "H" pulse width (Write)	15		ns	
	T <sub>SLW</sub>	SCL "L" pulse width (Write)	15		ns	
	T <sub>SCYCR</sub>	Serial clock cycle (Read)	150		ns	-read command & data ram
	T <sub>SHR</sub>	SCL "H" pulse width (Read)	60		ns	
	T <sub>SLR</sub>	SCL "L" pulse width (Read)	60		ns	
D/CX	T <sub>DCS</sub>	D/CX setup time	10		ns	
	T <sub>DCH</sub>	D/CX hold time	10		ns	
SDA (DIN)	T <sub>SDS</sub>	Data setup time	10		ns	
	T <sub>SDH</sub>	Data hold time	10		ns	
DOUT	T <sub>ACC</sub>	Access time	10	50	ns	For maximum CL=30pF
	T <sub>OH</sub>	Output disable time	15	50	ns	For minimum CL=8pF

## 6.4 Parallel RGB Interface Timing Characteristics



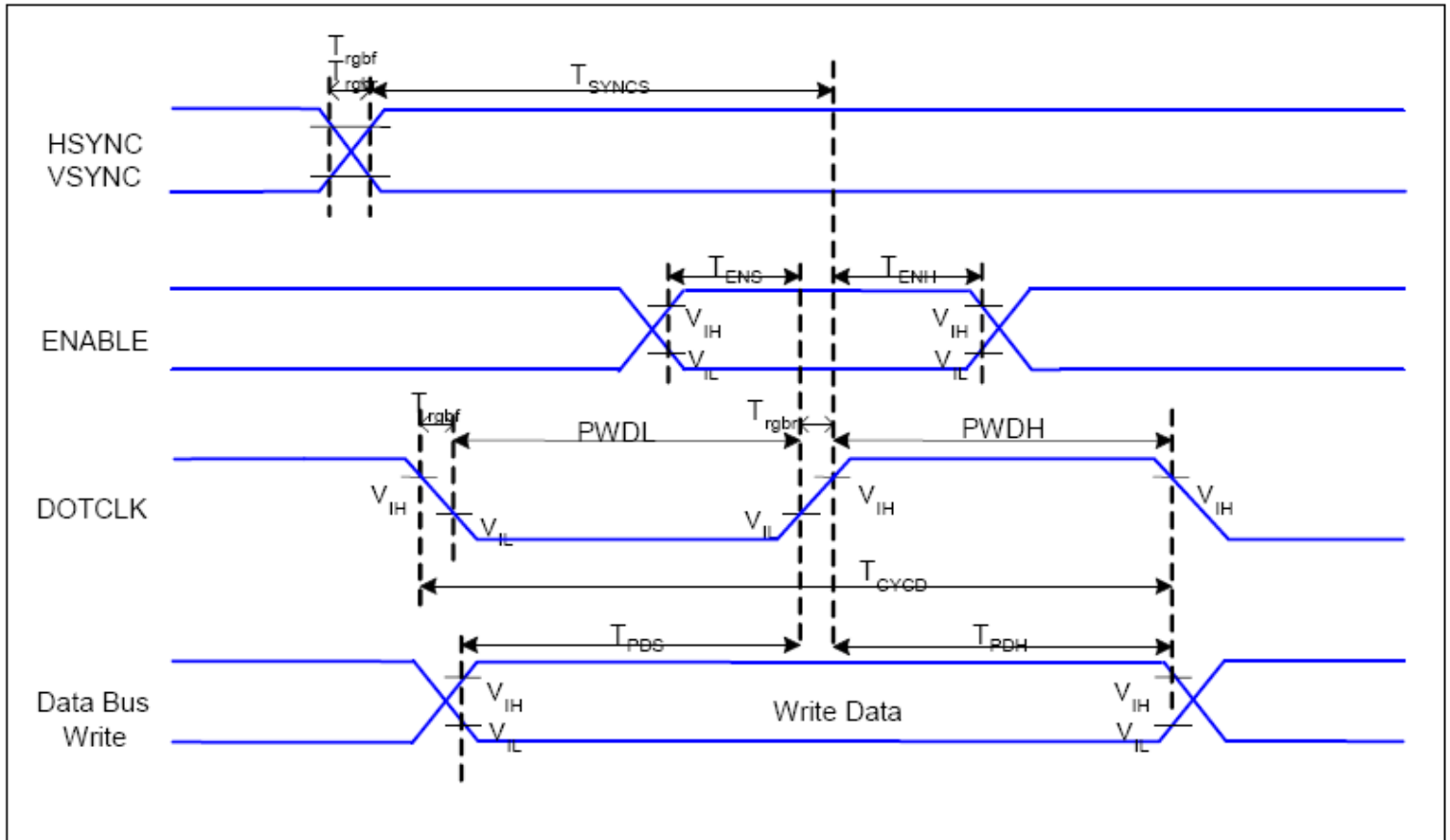

VDDI=1.65 to 3.3V, VDD=2.4 to 3.3V, AGND=DGND=0V, Ta=-30 ~ 70 °C

Signal	Symbol	Parameter	MIN	MAX	Unit	Description
HSYNC, VSYNC	$T_{SYNCS}$	VSYNC, HSYNC Setup Time	30	-	ns	
ENABLE	$T_{ENS}$	Enable Setup Time	25	-	ns	
	$T_{ENH}$	Enable Hold Time	25	-	ns	
DOTCLK	PWDH	DOTCLK High-level Pulse Width	60	-	ns	
	PWDL	DOTCLK Low-level Pulse Width	60	-	ns	
	$T_{CYCD}$	DOTCLK Cycle Time	120	-	ns	
	Trghr, Trghf	DOTCLK Rise/Fall time	-	20	ns	
DB	$T_{PDS}$	PD Data Setup Time	50	-	ns	
	$T_{PDH}$	PD Data Hold Time	50	-	ns	

## 6.5 Reset Timing Characteristics

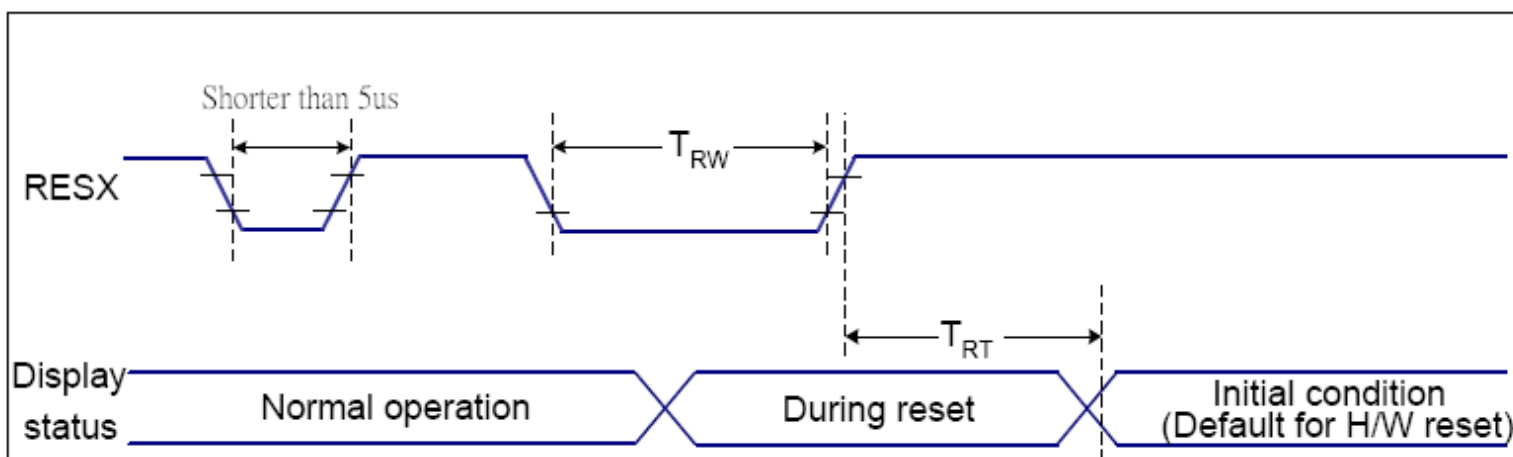

VDDI=1.65 to 3.3V, VDD=2.4 to 3.3V, AGND=DGND=0V,  $T_a = -30 \sim 70 \text{ }^\circ\text{C}$

Related Pins	Symbol	Parameter	MIN	MAX	Unit
RESX	TRW	Reset pulse duration	10	-	us
	TRT	Reset cancel	-	5 (Note 1, 5)	ms
			120 (Note 1, 6, 7)	ms	

Notes:

1. The reset cancel includes also required time for loading ID bytes, VCOM setting and other settings from NVM (or similar device) to registers. This loading is done every time when there is HW reset cancel time ( $t_{RT}$ ) within 5 ms after a rising edge of RESX.

2. Spike due to an electrostatic discharge on RESX line does not cause irregular system reset according to the table below:

RESX Pulse	Action
Shorter than 5us	Reset Rejected
Longer than 9us	Reset
Between 5us and 9us	Reset starts

3. During the Resetting period, the display will be blanked (The display is entering blanking sequence, which maximum time is 120 ms, when Reset Starts in Sleep Out –mode. The display remains the blank state in Sleep In –mode.) and then return to Default condition for Hardware Reset.

4. Spike Rejection also applies during a valid reset pulse as shown below:

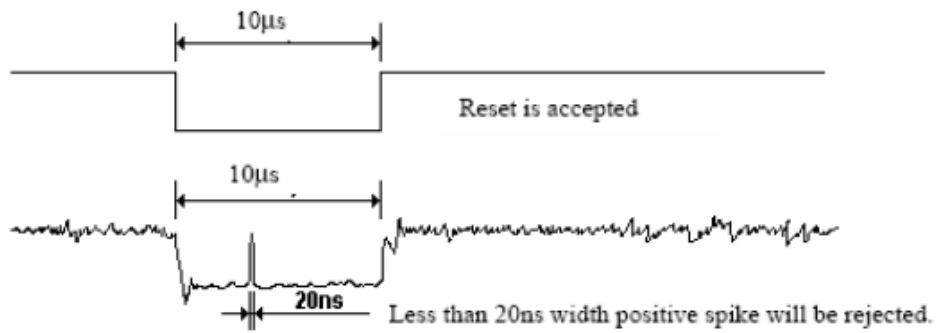

5. When Reset applied during Sleep In Mode.

6. When Reset applied during Sleep Out Mode.

7. It is necessary to wait 5msec after releasing RESX before sending commands. Also Sleep Out command cannot be sent for 120msec.

MIDAS  
DISPLAYS

DESIGN • MANUFACTURE • SUPPLY

## 7. LCD Module Out-Going Quality Level



## 7.1 VISUAL & FUNCTION INSPECTION STANDARD

### 7.1.1 Inspection conditions

Inspection performed under the following conditions is recommended.

Temperature :  $25 \pm 5^\circ\text{C}$

Humidity :  $65\% \pm 10\% \text{RH}$

Viewing Angle : Normal viewing Angle.

Illumination: Single fluorescent lamp (300 to 700Lux)

Viewing distance: 30-50cm

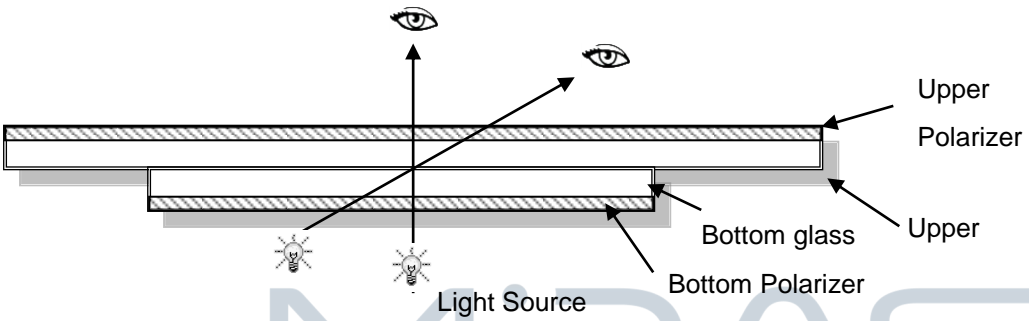

### 7.1.2 Definition

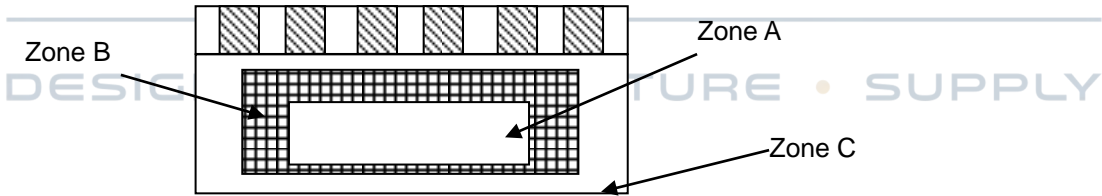

Zone A : Effective Viewing Area(Character or Digit can be seen)

Zone B : Viewing Area except Zone A

Zone C : Outside (Zone A+Zone B) which can not be seen after assembly by customer .)

Note:

As a general rule ,visual defects in Zone C can be ignored when it doesn't effect product function or appearance after assembly by customer.

### 7.1.3 Sampling Plan

According to GB/T 2828-2003 ; , normal inspection, Class II

AQL:

Major defect	Minor defect
0.65	1.5



LCD: Liquid Crystal Display , TP: Touch Panel , LCM: Liquid Crystal Module

No	Items to be inspected	Criteria	Classification of defects
1	Functional defects	1) No display, Open or miss line 2) Display abnormally, Short 3) Backlight no lighting, abnormal lighting. 4) TP no function	Major
2	Missing	Missing component	
3	Outline dimension	Overall outline dimension beyond the drawing is not allowed	
4	Color tone	Color unevenness, refer to limited sample	Minor
5	Soldering appearance	Good soldering , Peeling off is not allowed.	
6	LCD/Polarizer/TP	Black/White spot/line, scratch, crack, etc.	



DESIGN • MANUFACTURE • SUPPLY

#### 7.1.4 Criteria (Visual)

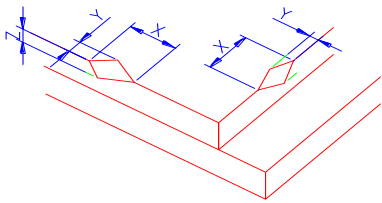
Number	Items	Criteria(mm)						
1.0 LCD Crack/Broken	(1) The edge of LCD broken	 <table border="1" data-bbox="868 1935 1442 2085"> <thead> <tr> <th>X</th> <th>Y</th> <th>Z</th> </tr> </thead> <tbody> <tr> <td>≤3.0mm</td> <td>&lt;Inner border line of the seal</td> <td>≤T</td> </tr> </tbody> </table>	X	Y	Z	≤3.0mm	<Inner border line of the seal	≤T
X	Y	Z						
≤3.0mm	<Inner border line of the seal	≤T						

NOTE:  
X: Length  
Y: Width

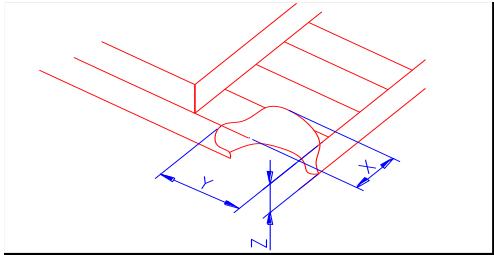
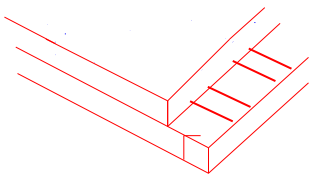

<p>Z: Height of ITO, L: Length of ITO, T: Height of LCD</p>	<p>(2)LCD corner broken</p>	 <table border="1" data-bbox="933 481 1375 577"> <tr> <td>X</td> <td>Y</td> <td>Z</td> </tr> <tr> <td>≤3.0mm</td> <td>≤L</td> <td>≤T</td> </tr> </table>	X	Y	Z	≤3.0mm	≤L	≤T
X	Y	Z						
≤3.0mm	≤L	≤T						
	<p>(3) LCD crack</p>	 <p>Crack Not allowed</p>						



Number	DESIGN	MANUFACTURE	Criteria (mm)	SUPPLY
--------	--------	-------------	---------------	--------

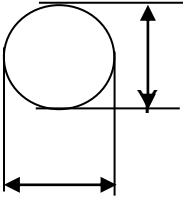

2.0	<p>Spot defect</p>  <p>X</p> <p><math>\Phi = (X+Y)/2</math></p>	<p>① light dot (LCD/TP/Polarizer black/white spot , light dot, pinhole, dent, stain)</p> <table border="1" data-bbox="451 241 1316 600"> <thead> <tr> <th rowspan="2">Zone Size (mm)</th> <th colspan="3">Acceptable Qty</th> </tr> <tr> <th>A</th> <th>B</th> <th>C</th> </tr> </thead> <tbody> <tr> <td><math>\Phi \leq 0.10</math></td> <td colspan="3">Ignore</td> </tr> <tr> <td><math>0.10 &lt; \Phi \leq 0.20</math></td> <td colspan="3">3( distance <math>\geq 10</math>mm)</td> </tr> <tr> <td><math>0.20 &lt; \Phi \leq 0.25</math></td> <td colspan="3">2</td> </tr> <tr> <td><math>\Phi &gt; 0.25</math></td> <td colspan="3">0</td> </tr> </tbody> </table> <p>② Dim spot (LCD/TP/Polarizer dim dot, light leakage, dark spot)</p> <table border="1" data-bbox="451 649 1316 1008"> <thead> <tr> <th rowspan="2">Zone Size (mm)</th> <th colspan="3">Acceptable Qty</th> </tr> <tr> <th>A</th> <th>B</th> <th>C</th> </tr> </thead> <tbody> <tr> <td><math>\Phi \leq 0.1</math></td> <td colspan="3">Ignore</td> </tr> <tr> <td><math>0.10 &lt; \Phi \leq 0.20</math></td> <td colspan="3">3( distance <math>\geq 10</math>mm)</td> </tr> <tr> <td><math>0.20 &lt; \Phi \leq 0.30</math></td> <td colspan="3">2</td> </tr> <tr> <td><math>\Phi &gt; 0.30</math></td> <td colspan="3">0</td> </tr> </tbody> </table> <p>③ Polarizer accidented spot</p> <table border="1" data-bbox="451 1057 1316 1332"> <thead> <tr> <th rowspan="2">Zone Size (mm)</th> <th colspan="3">Acceptable Qty</th> </tr> <tr> <th>A</th> <th>B</th> <th>C</th> </tr> </thead> <tbody> <tr> <td><math>\Phi \leq 0.2</math></td> <td colspan="3">Ignore</td> </tr> <tr> <td><math>0.3 &lt; \Phi \leq 0.5</math></td> <td colspan="3">2( distance <math>\geq 10</math>mm)</td> </tr> <tr> <td><math>\Phi &gt; 0.5</math></td> <td colspan="3">0</td> </tr> </tbody> </table>	Zone Size (mm)	Acceptable Qty			A	B	C	$\Phi \leq 0.10$	Ignore			$0.10 < \Phi \leq 0.20$	3( distance $\geq 10$ mm)			$0.20 < \Phi \leq 0.25$	2			$\Phi > 0.25$	0			Zone Size (mm)	Acceptable Qty			A	B	C	$\Phi \leq 0.1$	Ignore			$0.10 < \Phi \leq 0.20$	3( distance $\geq 10$ mm)			$0.20 < \Phi \leq 0.30$	2			$\Phi > 0.30$	0			Zone Size (mm)	Acceptable Qty			A	B	C	$\Phi \leq 0.2$	Ignore			$0.3 < \Phi \leq 0.5$	2( distance $\geq 10$ mm)			$\Phi > 0.5$	0		
Zone Size (mm)	Acceptable Qty																																																																		
	A	B	C																																																																
$\Phi \leq 0.10$	Ignore																																																																		
$0.10 < \Phi \leq 0.20$	3( distance $\geq 10$ mm)																																																																		
$0.20 < \Phi \leq 0.25$	2																																																																		
$\Phi > 0.25$	0																																																																		
Zone Size (mm)	Acceptable Qty																																																																		
	A	B	C																																																																
$\Phi \leq 0.1$	Ignore																																																																		
$0.10 < \Phi \leq 0.20$	3( distance $\geq 10$ mm)																																																																		
$0.20 < \Phi \leq 0.30$	2																																																																		
$\Phi > 0.30$	0																																																																		
Zone Size (mm)	Acceptable Qty																																																																		
	A	B	C																																																																
$\Phi \leq 0.2$	Ignore																																																																		
$0.3 < \Phi \leq 0.5$	2( distance $\geq 10$ mm)																																																																		
$\Phi > 0.5$	0																																																																		
	<p>Line defect (LCD/TP /Polarizer black/white line, scratch, stain)</p>	<table border="1" data-bbox="451 1411 1316 1758"> <thead> <tr> <th rowspan="2">Width(mm)</th> <th rowspan="2">Length(mm)</th> <th colspan="3">Acceptable Qty</th> </tr> <tr> <th>A</th> <th>B</th> <th>C</th> </tr> </thead> <tbody> <tr> <td><math>\Phi \leq 0.03</math></td> <td>Ignore</td> <td colspan="3">Ignore</td> </tr> <tr> <td><math>0.03 &lt; W \leq 0.05</math></td> <td><math>L \leq 3.0</math></td> <td colspan="3"><math>N \leq 2</math></td> </tr> <tr> <td><math>0.05 &lt; W \leq 0.08</math></td> <td><math>L \leq 2.0</math></td> <td colspan="3"><math>N \leq 2</math></td> </tr> <tr> <td><math>0.08 &lt; W</math></td> <td colspan="4">Define as spot defect</td> </tr> </tbody> </table>	Width(mm)	Length(mm)	Acceptable Qty			A	B	C	$\Phi \leq 0.03$	Ignore	Ignore			$0.03 < W \leq 0.05$	$L \leq 3.0$	$N \leq 2$			$0.05 < W \leq 0.08$	$L \leq 2.0$	$N \leq 2$			$0.08 < W$	Define as spot defect																																								
Width(mm)	Length(mm)	Acceptable Qty																																																																	
		A	B	C																																																															
$\Phi \leq 0.03$	Ignore	Ignore																																																																	
$0.03 < W \leq 0.05$	$L \leq 3.0$	$N \leq 2$																																																																	
$0.05 < W \leq 0.08$	$L \leq 2.0$	$N \leq 2$																																																																	
$0.08 < W$	Define as spot defect																																																																		
3.0	<p>Polarizer Bubble</p>	<table border="1" data-bbox="451 1848 1220 2116"> <thead> <tr> <th rowspan="2">Zone Size (mm)</th> <th colspan="3">Acceptable Qty</th> </tr> <tr> <th>A</th> <th>B</th> <th>C</th> </tr> </thead> <tbody> <tr> <td><math>\Phi \leq 0.2</math></td> <td colspan="3">Ignore</td> </tr> <tr> <td><math>0.2 &lt; \Phi \leq 0.4</math></td> <td colspan="3">3(distance <math>\geq 10</math> m)</td> </tr> <tr> <td><math>0.4 &lt; \Phi \leq 0.6</math></td> <td colspan="3">2</td> </tr> <tr> <td><math>0.6 &lt; \Phi</math></td> <td colspan="3">0</td> </tr> </tbody> </table>	Zone Size (mm)	Acceptable Qty			A	B	C	$\Phi \leq 0.2$	Ignore			$0.2 < \Phi \leq 0.4$	3(distance $\geq 10$ m)			$0.4 < \Phi \leq 0.6$	2			$0.6 < \Phi$	0																																												
Zone Size (mm)	Acceptable Qty																																																																		
	A	B	C																																																																
$\Phi \leq 0.2$	Ignore																																																																		
$0.2 < \Phi \leq 0.4$	3(distance $\geq 10$ m)																																																																		
$0.4 < \Phi \leq 0.6$	2																																																																		
$0.6 < \Phi$	0																																																																		

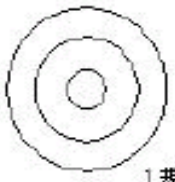
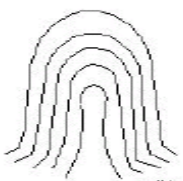

4.0	SMT	According to IPC-A-610C class II standard . Function defect and missing part are major defect ,the others are minor defect.
-----	-----	---

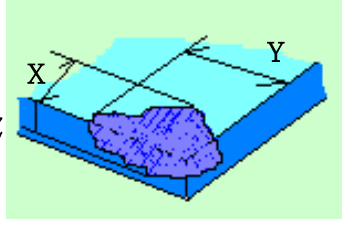
5.0	TP Related	TP bubble/ accidented spot	<table border="1"> <thead> <tr> <th rowspan="2">Size <math>\Phi</math>(mm)</th> <th colspan="3">Acceptable Qty</th> </tr> <tr> <th>A</th> <th>B</th> <th>C</th> </tr> </thead> <tbody> <tr> <td><math>\Phi \leq 0.1</math></td> <td colspan="3">Ignore</td> </tr> <tr> <td><math>0.1 &lt; \Phi \leq 0.25</math></td> <td colspan="3">3 (distance <math>\geq</math></td> </tr> <tr> <td><math>0.25 &lt; \Phi \leq 0.3</math></td> <td colspan="3">2</td> </tr> <tr> <td><math>0.3 &lt; \Phi</math></td> <td colspan="3">0</td> </tr> </tbody> </table>	Size $\Phi$ (mm)	Acceptable Qty			A	B	C	$\Phi \leq 0.1$	Ignore			$0.1 < \Phi \leq 0.25$	3 (distance $\geq$			$0.25 < \Phi \leq 0.3$	2			$0.3 < \Phi$	0		
		Size $\Phi$ (mm)	Acceptable Qty																							
			A	B	C																					
$\Phi \leq 0.1$	Ignore																									
$0.1 < \Phi \leq 0.25$	3 (distance $\geq$																									
$0.25 < \Phi \leq 0.3$	2																									
$0.3 < \Phi$	0																									
Assembly deflection	beyond the edge of backlight $\leq 0.15\text{mm}$																									
Newton Ring	<p>Newton Ring area <math>&gt; 1/3</math> TP area NG</p> <p>Newton Ring area <math>\leq 1/3</math> TP area OK</p>	 1 规律性  2 非规律性  似牛顿环																								
TP corner broken X : length Y : width Z : height	<table border="1"> <thead> <tr> <th>X</th> <th>Y</th> <th>Z</th> </tr> </thead> <tbody> <tr> <td><math>X \leq 3.0\text{mm}</math></td> <td><math>Y \leq 3.0\text{mm}</math></td> <td><math>Z &lt; \text{LCD thickness}</math></td> </tr> </tbody> </table> <p>* Circuitry broken is not allowed.</p>	X	Y	Z	$X \leq 3.0\text{mm}$	$Y \leq 3.0\text{mm}$	$Z < \text{LCD thickness}$																			
X	Y	Z																								
$X \leq 3.0\text{mm}$	$Y \leq 3.0\text{mm}$	$Z < \text{LCD thickness}$																								

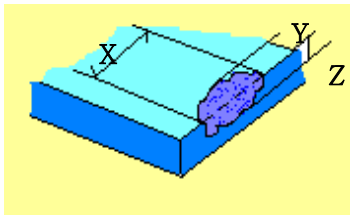

		TP edge broken X : length Y : width Z : height	<table border="1"> <tr> <td>X</td> <td>Y</td> <td>Z</td> </tr> <tr> <td>X≤6.0mm</td> <td>Y≤2.0mm</td> <td>Z&lt;LCD thickness</td> </tr> </table>	X	Y	Z	X≤6.0mm	Y≤2.0mm	Z<LCD thickness	
X	Y	Z								
X≤6.0mm	Y≤2.0mm	Z<LCD thickness								

**Criteria ( functional items)**

Number	Items	Criteria (mm)
1	No display	Not allowed
2	Missing segment	Not allowed
3	Short	Not allowed
4	Backlight no lighting	Not allowed
5	TP no function	Not allowed

**8. Reliability Test Result**

**8.1 Condition**

Item	Condition	Sample Size	Test Result	Note
Low Temperature Operating Life test	-20°C, 96HR	3ea	pass	-
Thermal Humidity Operating Life test	70°C90%RH, 96HR	3ea	pass	-
Temperature Cycle ON/OFF test	-20°C ↔ 70°C, ON/OFF, 20CYC	3ea	pass	(1)
High Temperature Storage test	80°C, 96HR	3ea	pass	-
Low Temperature Storage test	- 30°C, 96HR	3ea	pass	-
ESD test	150pF, 330Ω , ±6KV(Contact)/± 8KV(Air), 5 points/panel, 10 times/point	3ea	pass	



Thermal Shock Resistance	The sample should be allowed to stand the following 5 cycles of operation: TSTL for 30 minutes -> normal temperature for 5 minutes -> TSTH for 30 minutes -> normal temperature for 5 minutes, as one cycle, then taking it out and drying it at normal temperature, and allowing it stand for 24 hours	3ea	pass	
Box Drop Test	1 Corner 3 Edges 6 faces, 66cm(MEDIUM BOX)	1box	pass	-

Note (1) ON Time over 10 seconds, OFF Time under 10 seconds

## 9. Cautions and Handling Precautions

### 9.1 Handling and Operating the Module

- (1) When the module is assembled, it should be attached to the system firmly.  
Do not warp or twist the module during assembly work.
- (2) Protect the module from physical shock or any force. In addition to damage, this may cause improper operation or damage to the module and back-light unit.
- (3) Note that polarizer is very fragile and could be easily damaged. Do not press or scratch the surface.
- (4) Do not allow drops of water or chemicals to remain on the display surface.  
If you have the droplets for a long time, staining and discoloration may occur.
- (5) If the surface of the polarizer is dirty, clean it using some absorbent cotton or soft cloth.
- (6) The desirable cleaners are water, IPA (Isopropyl Alcohol) or Hexane.  
Do not use ketene type materials (ex. Acetone), Ethyl alcohol, Toluene, Ethyl acid or Methyl chloride. It might permanent damage to the polarizer due to chemical reaction.
- (7) If the liquid crystal material leaks from the panel, it should be kept away from the eyes or mouth. In case of contact with hands, legs, or clothes, it must be washed away thoroughly with soap.
- (8) Protect the module from static; it may cause damage to the CMOS ICs.
- (9) Use finger-stalls with soft gloves in order to keep display clean during the incoming inspection and assembly process.
- (10) Do not disassemble the module.
- (11) Protection film for polarizer on the module shall be slowly peeled off just before use so that the electrostatic charge can be minimized.
- (12) Pins of I/F connector shall not be touched directly with bare hands.
- (13) Do not connect, disconnect the module in the "Power ON" condition.
- (14) Power supply should always be turned on/off by the item 6.1 Power On Sequence & 6.2 Power Off Sequence

### 9.2 Storage and Transportation.

- (1) Do not leave the panel in high temperature, and high humidity for a long time.  
It is highly recommended to store the module with temperature from 0 to 35 °C and relative humidity of less than 70%
- (2) Do not store the TFT-LCD module in direct sunlight.



(3) The module shall be stored in a dark place. When storing the modules for a long time, be sure to adopt effective measures for protecting the modules from strong ultraviolet radiation, sunlight, or fluorescent light.

(4) It is recommended that the modules should be stored under a condition where no condensation is allowed. Formation of dewdrops may cause an abnormal operation or a failure of the module.

In particular, the greatest possible care should be taken to prevent any module from being operated where condensation has occurred inside.

(5) This panel has its circuitry FPC on the bottom side and should be handled carefully in order not to be stressed.

## 10. Packing

----TBD-----



---

DESIGN • MANUFACTURE • SUPPLY

