

LIQUID CRYSTAL DISPLAY MODULE

Product Specification

CUSTOMER	Standard
CUSTOMER PART NUMBER	
PRODUCT NUMBER	DMT070WVNTNT0-1A

Authorised By	Created By
Luo Luo	Eric Wan
Date: 14-Nov-17	Date: 04-Nov-17

TABLE OF CONTENTS

1	MAIN FEATURES	4
2	MECHANICAL SPECIFICATION	5
2.1	MECHANICAL CHARACTERISTICS.....	5
2.2	MECHANICAL DRAWING.....	6
3	ELECTRICAL SPECIFICATION	7
3.1	ABSOLUTE MAXIMUM RATINGS.....	7
3.2	DC ELECTRICAL CHARACTERISTICS	7
3.3	INTERFACE PIN ASSIGNMENT	8
3.4	TIMING CHARACTERISTICS	10
3.5	POWER SEQUENCE	12
4	OPTICAL SPECIFICATION	13
4.1	OPTICAL CHARACTERISTICS.....	13
5	BACKLIGHT SPECIFICATION	15
5.1	LED DRIVING CONDITIONS	15
5.2	LED CIRCUIT	15
6	QUALITY ASSURANCE SPECIFICATION	16
6.1	DELIVERY INSPECTION STANDARDS	16
6.2	DEALING WITH CUSTOMER COMPLAINTS.....	21
7	RELIABILITY SPECIFICATION	22
7.1	RELIABILITY TESTS.....	22
8	HANDLING PRECAUTIONS	23

REVISION RECORD

Rev.	Date	Page	Chapt.	Comment	ECN no.
1.0	04-Nov-17			Initial Release	

1 MAIN FEATURES

ITEM	CONTENTS
Screen Size	7.0" Diagonal
Display Format	800 x RGB x 480 Dots
N° of Colour	65K/262K/16.7M
TFT Active Area	152.40 mm (H) x 91.44 mm (V)
LCD Type	TFT
Mode	Transmissive / Normally Black
Viewing Direction	ALL
TFT Interface	16/18/24-bit RGB interface
TFT Driver IC	SC5004 and SC5005
Backlight Type	LED
Operating Temperature	-30°C ~ +85°C
Storage Temperature	-40°C ~ +90°C
RoHS compliant	Yes

2 MECHANICAL SPECIFICATION

2.1 MECHANICAL CHARACTERISTICS

ITEM	CHARACTERISTIC	UNIT
Overall Dimensions	165.4 mm (H) x 104.59 mm (V) x 5.8 mm (D)	mm
pixel Pitch	0.1905(H) x 0.1905 (V)	mm
Weight	124	g

2.2 MECHANICAL DRAWING

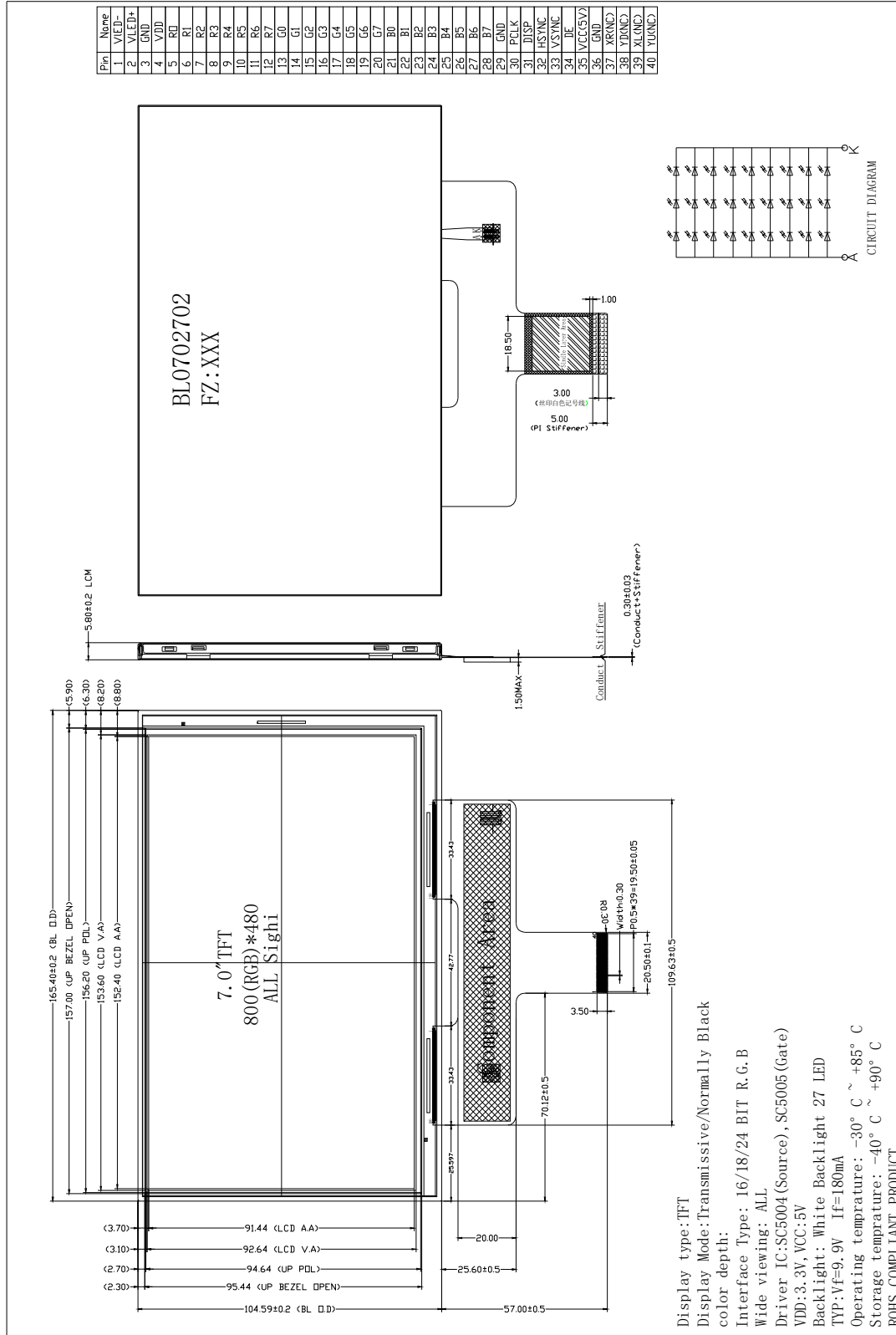

3 ELECTRICAL SPECIFICATION

3.1 ABSOLUTE MAXIMUM RATINGS

Item	Symbol	Condition	Min	Max	Unit	Note
Power Supply Voltage1	VDD		-0.3	4.0	V	
Power Supply Voltage2	VCC		-0.3	7.0	V	
Operating Temperature	TOP		-30	85	°C	1
Storage Temperature	TST		-40	90	°C	1,2,3

Note 1. 90 % RH Max for Ta<50 °C, and 60% RH for Ta≥50°C.

Note 2. In case of below 0°C, the response time of liquid crystal (LC) becomes slower and the colour of panel becomes darker than normal one. Level of retardation depends on temperature, because of LC's characteristic.

Note 3. Only operation is guaranteed at operating temperature. Contrast, response time, another display quality are evaluated at +25°C.

3.2 DC ELECTRICAL CHARACTERISTICS

Item	Symbol	Condition	Min	Typ	Max	Unit	Note
Power Supply Voltage1	VDD	Ta=25°C	3.0	3.3	3.6	V	
Power Supply Voltage2	VCC	Ta=25°C	3.3	5.0	5.5	V	
Input Voltage for Logic	VIH		0.7VDD	-	VDD	V	
	VIL		GND	-	0.3 VDD	V	
Output Voltage for Logic	VOH		0.8VDD	-	VDD	V	
	VOL		GND	-	0.2VDD	V	
Current Consumption 1	IDD		-	11	-	mA	1
Current Consumption 2	ICC			113		mA	2

Note 1: The specified power consumption is under the conditions of VDD=3.3V.

Note 2: The specified power consumption is under the conditions of VCC=5.0V.

3.3 INTERFACE PIN ASSIGNMENT

NO.	SYMBOL	DISCRIPTION
1	LEDK	Cathode pin of backlight
2	LEDA	Anode pin of backlight
3	GND	Ground.
4	VDD	Supply voltage(3.3V).
5	R0	Red data input.
6	R1	Red data input.
7	R2	Red data input.
8	R3	Red data input.
9	R4	Red data input.
10	R5	Red data input.
11	R6	Red data input.
12	R7	Red data input.
13	G0	Green data input.
14	G1	Green data input.
15	G2	Green data input.
16	G3	Green data input.
17	G4	Green data input.
18	G5	Green data input.
19	G6	Green data input.
20	G7	Green data input.
21	B0	Blue data input.
22	B1	Blue data input.
23	B2	Blue data input.
24	B3	Blue data input.
25	B4	Blue data input.
26	B5	Blue data input.

Product No.	DMT070WVNTNT0-1A	REV. 1.0	Page	8 / 23
-------------	------------------	----------	------	--------

27	B6	Blue data input.
28	B7	Blue data input.
29	GND	Ground.
30	PCLK	Clock signal. Latching data at the rising edge
31	DISP	Standby setting for testing, it should be connected to VDD in normal operation mode. If connected to GND, the IC is in standby mode.
32	HSYNC	Horizontal Sync input. Negative polarity.
33	VSYNC	Vertical Sync input. Negative polarity.
34	DE	Data input Enable. Active High to enable the data input Bus under "DE Mode".
35	VCC	Supply voltage for DC booster circuit (5.0V).
36	GND	Ground.
37	XR(NC)	Resistive touch panel Right Glass Terminal(Not Connected)
38	YD(NC)	Resistive touch panel Bottom Film Terminal(Not Connected)
39	XL(NC)	Resistive touch panel Left Glass Terminal(Not Connected)
40	YU(NC)	Resistive touch panel Top Film Terminal(Not Connected)

3.4 TIMING CHARACTERISTICS

3.4.1 Display RGB (DPI) Interface Timing

Vertical input timing

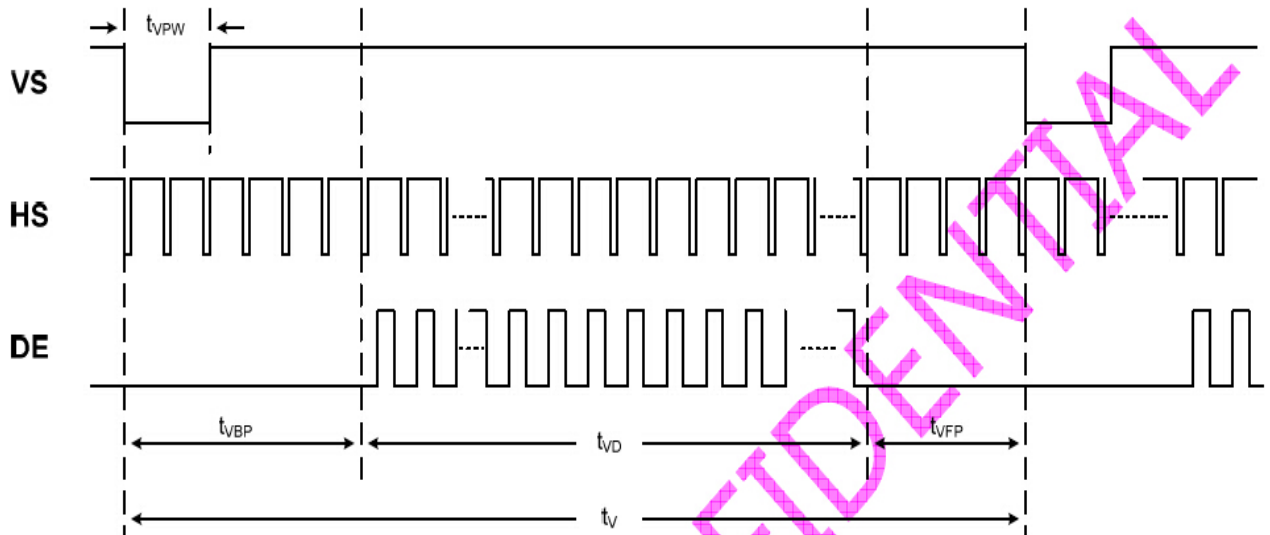

Horizontal input timing

(CLK_POL=L)

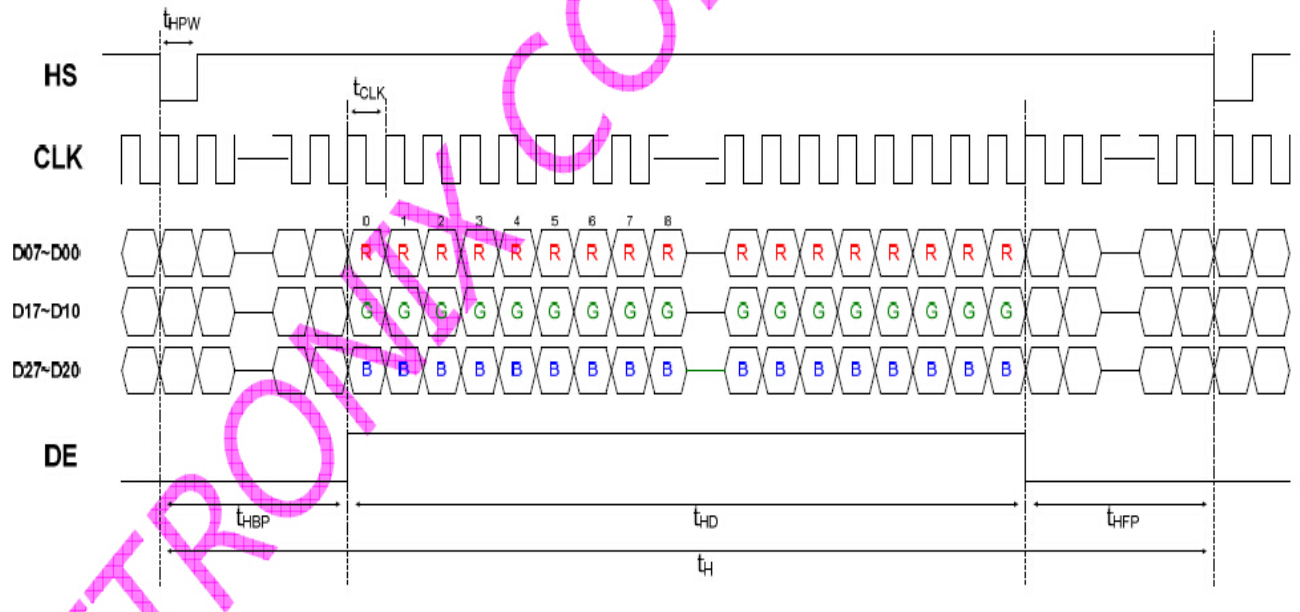

3.4.2 Parallel RGB Interface Timing Characteristics

(VDD=VDD_LVDS=3.0~3.6V, GND=GND_LVDS=0V, TA=-20~85°C)

Parameter	Symbol	Min	Typ.	Max.	Unit	Conditions
CLK cycle time	t _{CPH}	16.7			ns	
CLK pulse high duty	t _{CWH}	40	50	60	%	
CLK pulse low duty	t _{CWL}	40	50	60	%	
VS setup time	t _{VST}	4	-	-	ns	
VS hold time	t _{VHD}	2	-	-	ns	
HS setup time	t _{HST}	4	-	-	ns	
HS hold time	t _{HHD}	2	-	-	ns	
Data setup time	t _{DSH}	4	-	-	ns	D0[7:0], D1[7:0], D2[7:0] to CLK
Date hold time	t _{DHD}	2	-	-	ns	D0[7:0], D1[7:0], D2[7:0] to CLK
DE setup time	t _{ESU}	4	-	-	ns	
DE hold time	t _{EHD}	2	-	-	ns	

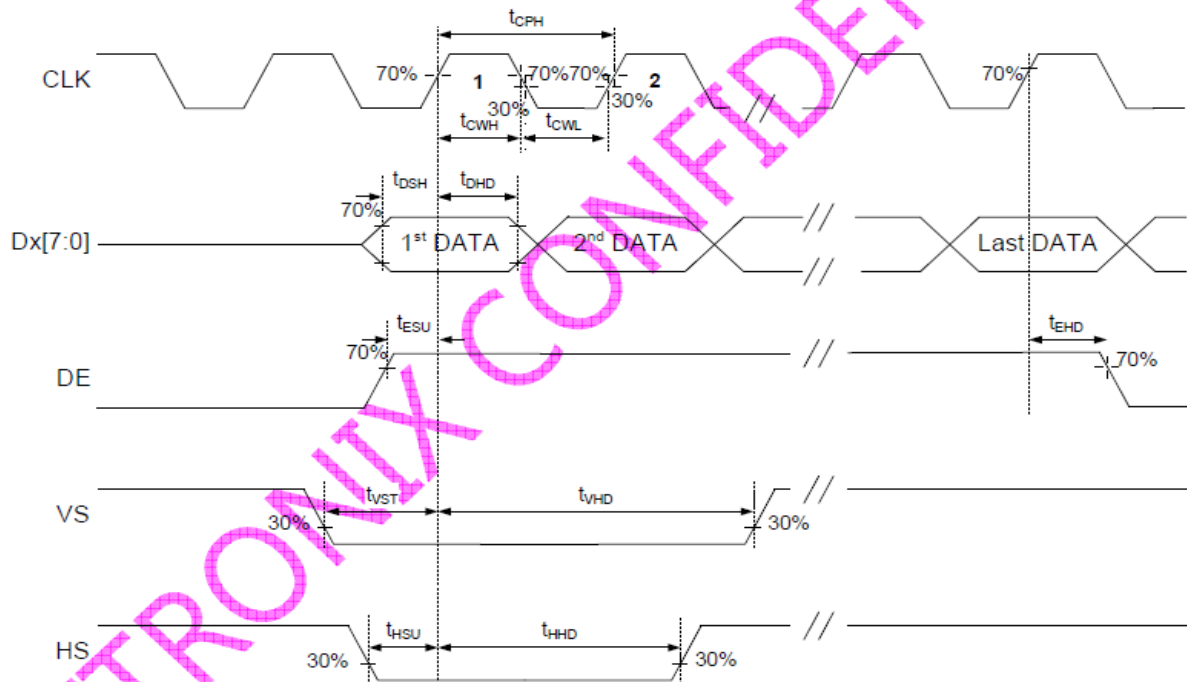

Note: Upper timing diagram CLK_POL=H, DE_POL=L, VS_POL=L, HS_POL=L

Parameter	Symbol	Value			Unit	Note
		Min.	Typ.	Max.		
CLK frequency	t _{CLK}	25.9	27.6	48.7	Mhz	
Horizontal blanking time	t _{HBT}	90	110	304	t _{CLK}	t _{HBP} + t _{HFP}
Horizontal back porch	t _{HBP}	5	5	304 - t _{HFP}	t _{CLK}	
Horizontal display area	t _{HD}	800	800	800	t _{CLK}	
Horizontal front porch	t _{HFP}	85	105	299	t _{CLK}	
Horizontal period	t _H	890	910	1104	t _{CLK}	
Horizontal pulse width	t _{HPW}	1	1	256	t _{CLK}	
Vertical blanking time	t _{VBT}	5	26	255	t _H	t _{VBP} + t _{VFP}
Vertical back porch	t _{VBP}	2	2	255 - t _{VFP}	t _H	
Vertical display area	t _{VD}	480	480	480	t _H	
Vertical front porch	t _{VFP}	3	24	253	t _H	
Vertical period	t _V	485	506	735	t _H	
Vertical pulse width	t _{VPW}	1	1	128	t _H	

3.5 POWER SEQUENCE

3.5.1 Power on/off Sequence

For TFT-LCD module, please follow below timings to prevent IC damage from abnormal power on or off sequence.

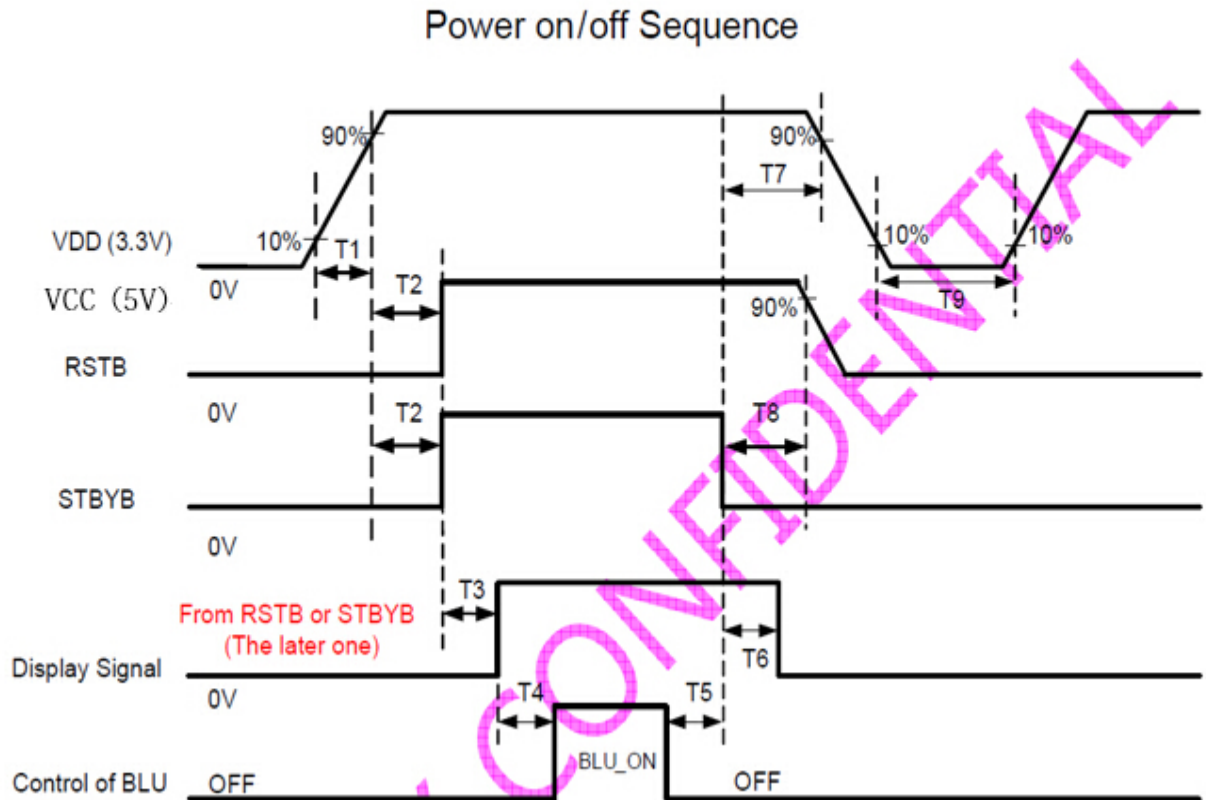

$T1 \leq 3\text{ms}$ $1\text{ms} \leq T2$ $3.5\text{ms} \leq T3 \leq \text{IBF}-50\text{ms}$ $\text{IBF}+20\text{ms} \leq T3 + T4$
--

$0 < T5$ $20\text{ms} \leq T6 \leq 50\text{ms}$ $120\text{ms} \leq T7$ $120\text{ms} \leq T8$ $200\text{ms} \leq T9$
--

For continuously power off and on, please make sure the external VDD, VGH & VGL are discharged completely before you restart it.

Note that IBF is STSC5004's internal timing frames, selected by registers. Please refer to register list for detail.

4 OPTICAL SPECIFICATION

4.1 OPTICAL CHARACTERISTICS

Item	Symbol	Condition	MIN	TYP	MAX	Unit	Note	
Response Time	TR+TF	$\theta=\phi=0^\circ$ Normal Viewing Angle	-	35	40	ms	2	
Contrast Ratio	CR		--	1000	-		3	
Viewing Angle	Left	θ_L	CR ≥ 10	-	85	-	deg	4
	Right	θ_R		-	85	-	deg	
	Up	ϕ_U		-	85	-	deg	
	Down	ϕ_D		-	85	-	deg	
Colour Chromaticity	Red	Rx	CR ≥ 10	0.619	0.639	0.659	-	5
		Ry		0.318	0.338	0.358	-	
	Green	Gx		0.307	0.327	0.347	-	
		Gy		0.558	0.578	0.598	-	
	Blue	Bx		0.123	0.143	0.163	-	
		By		0.047	0.067	0.087	-	
	White	Wx		0.287	0.307	0.347	-	
		Wy		0.306	0.346	0.386	-	
Centre Brightness		If=180mA	400	450	-	cd/m ²	6	
Brightness Distribution			80		-	%	7	

4.1.1 Test Method

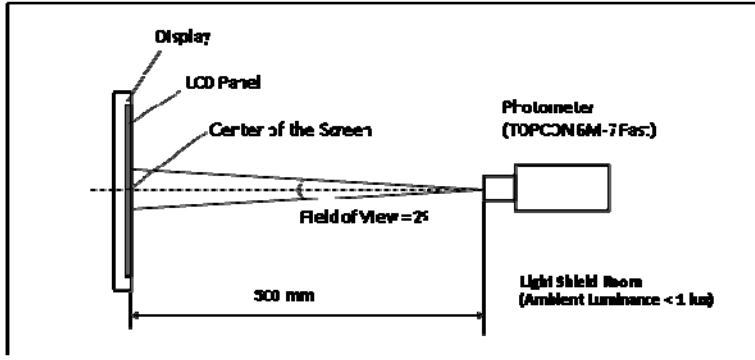
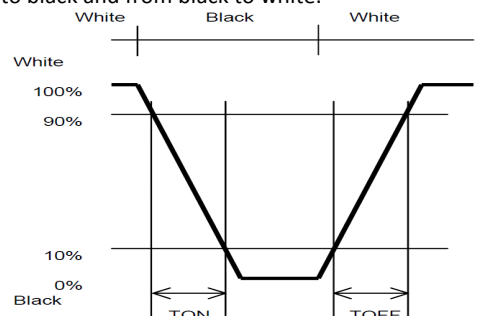
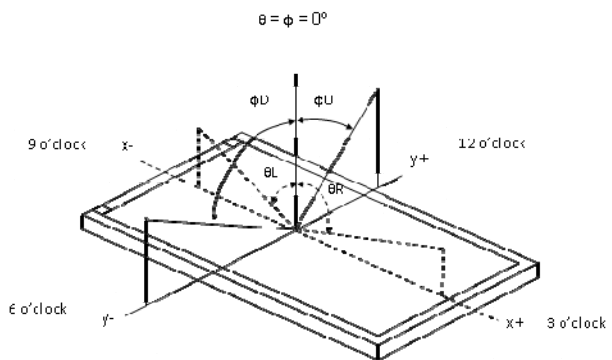
Note	Item	Test method
1	Setup	<p>The display should be stabilised at a given temperature for 30 minutes to avoid abrupt temperature change during measuring. In order to stabilise the luminance, measurements should be executed after lighting the backlight for 30 minutes in a windless room.</p> 
2	Response time	<p>Measure output signal waveform by the luminance meter when raster of window pattern is changed from white to black and from black to white.</p> 
3	Contrast ratio	<p>Measure maximum brightness and minimum brightness at the centre of the screen by displaying raster or window pattern. Then calculate the ratio between these two values.</p> $\text{Contrast Ratio (CR)} = \frac{\text{Brightness of unselected position (white)}}{\text{Brightness of selected position (black)}}$
4	Viewing angle Horizontal θ Vertical ϕ	<p>Move the luminance meter from right to left and up and down and determinate the angles where contrast ratio is 10</p> 
5	Colour chromaticity	Measure chromaticity coordinates x and y of CIE1931 colorimetric system
6	Centre brightness	Measure the brightness at the centre of the screen
7	Brightness distribution	<p>(Brightness distribution) = $100 \times B/A \%$ A: max. brightness of the 9 points B: min. brightness of the 9 points</p>

5 BACKLIGHT SPECIFICATION

5.1 LED DRIVING CONDITIONS

The back light system is edge-lighting type with 27 chips White LED

Item	Symbol	Condition	Min	Typ	Max	Unit
Forward Current	IF	Ta=25 °C,	170	180	-	mA
Forward Voltage	VF	Ta= 25°C,		9.9		V
LED life time	Hr	Ta= 25°C,	-	50K	-	Hour

Note:

- The lifetime of the LED is defined as a period till the brightness of the LED decreases to the half of its initial value.
- This figure is given as a reference purpose only, and not a guarantee.
- This figure is estimated for an LED operating alone.
The performance of an LED may differ when assembled as a monitor together with a TFT panel due to different environmental temperature.
- Estimated lifetime could vary on a different temperature and usually higher temperature could reduce the life significantly.

5.2 LED CIRCUIT

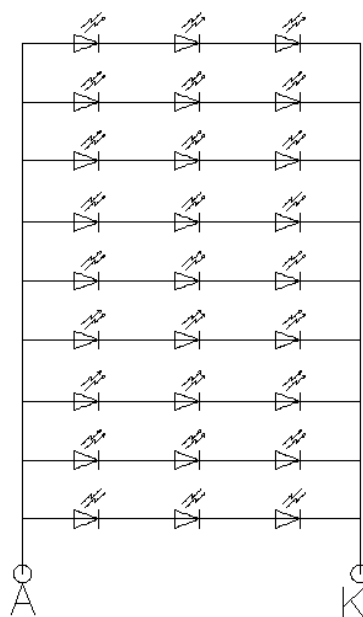

CIRCUIT DIAGRAM

6 QUALITY ASSURANCE SPECIFICATION

6.1 DELIVERY INSPECTION STANDARDS

6.1.1 Inspection Conditions

Inspection distance: 30 cm \pm 2 cm
Viewing angle: $\pm 45^\circ$

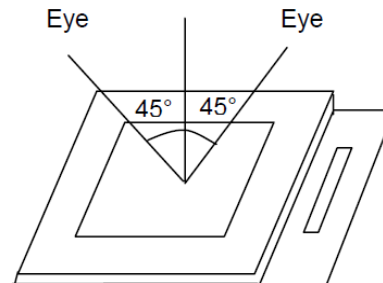

6.1.2 Environmental Conditions

Ambient temperature: 25°C \pm 5°C
Ambient humidity: 65 \pm 10% RH
Ambient illumination: 300~700 lux

6.1.3 Sampling Conditions

1. Lot size: quantity of shipment lot per model
2. Sampling method:

Sampling Plan		GB/T 2828-2003
		Normal inspection, Single Sampling, Class II
AQL	Major Defect	0.65%
	Minor Defect	1.5%

No	Items to be inspected	Criteria	Classification of defects
1	Functional defects	1) No display, Open or miss line 2) Display abnormally, Short 3) Backlight no lighting, abnormal lighting. 4) TP no function	Major
2	Missing	Missing component	
3	Outline dimension	Overall outline dimension beyond the drawing is not allowed	
4	Color tone	Color unevenness, refer to limited sample	Minor
5	Spot Line defect	Light dot , Dim spot, Polarizer Bubble ; Polarizer accidented spot.	
6	Soldering appearance	Good soldering , Peeling off is not allowed.	
7	LCD/Polarizer/TP	Black/White spot/line, scratch, crack, etc.	

6.1.4 Definition of Area

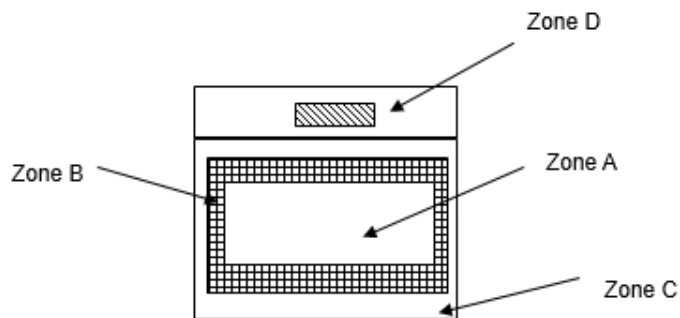

Zone A : Effective Viewing Area(Character or Digit can be seen)

Zone B : Viewing Area except Zone A

Zone C : Outside (Zone A+Zone B) which can not be seen after assembly by customer .)

Zone D : IC Bonding Area

Note:

As a general rule ,visual defects in Zone C can be ignored when it doesn't effect product function or appearance after assembly by customer

6.1.5 Basic Principle

A set of sample to indicate the limit of acceptable quality level shall be discussed should a dispute occur.

6.1.6 Inspection Criteria

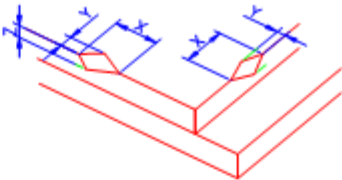
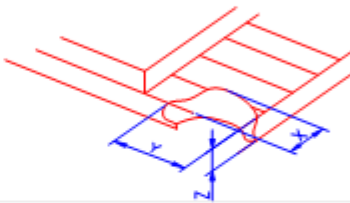
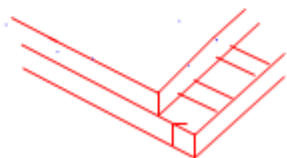
Number	Items	Criteria(mm)						
1.0 LCD Crack/Broken NOTE: X: Length Y: Width Z: Height L: Length of ITO, T: Height of LCD	(1) The edge of LCD broken	 <table border="1" data-bbox="762 638 1385 772"> <tr> <td>X</td> <td>Y</td> <td>Z</td> </tr> <tr> <td>≤3.0mm</td> <td><Inner border line of the seal</td> <td>≤T</td> </tr> </table>	X	Y	Z	≤3.0mm	<Inner border line of the seal	≤T
	X	Y	Z					
	≤3.0mm	<Inner border line of the seal	≤T					
(2)LCD corner broken	 <table border="1" data-bbox="833 1048 1316 1137"> <tr> <td>X</td> <td>Y</td> <td>Z</td> </tr> <tr> <td>≤3.0mm</td> <td>≤L</td> <td>≤T</td> </tr> </table>	X	Y	Z	≤3.0mm	≤L	≤T	
X	Y	Z						
≤3.0mm	≤L	≤T						
(3) LCD crack	 <p style="text-align: center;">Crack Not allowed</p>							

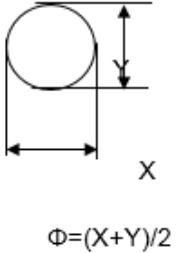
2.0	Spot defect	 <p style="text-align: center;">$\Phi=(X+Y)/2$</p>	① light dot (LCD/TP/Polarizer black/white spot , light dot, pinhole, dent, stain)		
	Zone		Acceptable Qty		
	Size (mm)		A	B	C
	$\Phi \leq 0.10$		Ignore		Ignore
	$0.10 < \Phi \leq 0.25$		4(distance $\geq 10\text{mm}$)		
$0.25 < \Phi \leq 0.35$	3				
$\Phi > 0.4$	0				
② Dim spot (LCD/TP/Polarizer dim dot, light leakage, dark spot)					
Zone	Acceptable Qty				
Size (mm)	A	B	C		
$\Phi \leq 0.1$	Ignore		Ignore		
$0.10 < \Phi \leq 0.25$	4(distance $\geq 10\text{mm}$)				
$0.25 < \Phi \leq 0.35$	3				
$\Phi > 0.4$	0				
③ Polarizer accidented spot					
Zone	Acceptable Qty				
Size (mm)	A	B	C		
$\Phi \leq 0.2$	Ignore		Ignore		
$0.3 < \Phi \leq 0.5$	3(distance $\geq 10\text{mm}$)				
$\Phi > 0.5$	1				
④ Pixel bad points (light dot, Dim dot, color dot)					
Zone	Acceptable Qty				
Size (mm)	A	B	C		
$\Phi \leq 0.15$	Ignore		Ignore		
$0.2 < \Phi \leq 0.3$	2(distance $\geq 10\text{mm}$)				
$\Phi > 0.4$	1				
⑤ Polarizer Bubble					
Zone	Acceptable Qty				
Size (mm)	A	B	C		
$\Phi \leq 0.2$	Ignore		Ignore		
$0.3 < \Phi \leq 0.4$	4(distance $\geq 10\text{mm}$)				
$0.4 < \Phi \leq 0.5$	3				
$\Phi > 0.5$	1				

3.0	Line defect (LCD/TP /Polarizer backlight black/white line, scratch, stain)	Width(mm)	Length(m m)	Acceptable Qty		
				A	B	C
		$\Phi \leq 0.05$	Ignore	Ignore		
		$0.05 < W \leq 0.06$	$L \leq 4.0$	N \leq 3		
		$0.07 < W \leq 0.08$	$L \leq 3.0$	N \leq 2		
	$0.08 < W$	Define as spot defect				
4.0	Electronic Comp onents SMT	Not allow missing parts , solderless connection , cold solder joint , mis match , The positive and negative polarity opposite				
5.0	Display color& B rightness	1. Color : Measuring the color coordinates, The measurement standar d according to the datasheet or samples. 2. Brightness : Measuring the brightness of White screen, The measu rement standard according to the datasheet or Samples.				

Criteria (functional items)

Number	Items	Criteria (mm)
1	No display	Not allowed
2	Missing segment	Not allowed
3	Short	Not allowed
4	Backlight no lighting	Not allowed

6.1.7 Classification of Defects

Visual defects (except no or wrong label) are treated as minor defects, while electrical defects are treated as major defects.

Two minor defects are equal to one major defect in lot sampling inspection.

6.1.8 Identification / Marking criteria

Any unit with illegible / wrong / double or no marking / label shall be rejected.

6.2 DEALING WITH CUSTOMER COMPLAINTS

6.2.1 Non-conforming analysis

Purchaser should supply Densitron with detailed data of non-conforming sample. After accepting it, Densitron should complete the analysis in two weeks from receiving the sample.

If the analysis cannot be completed on time, Densitron must inform the purchaser.

6.2.2 Handling of non-conforming displays

If any non-conforming displays are found during customer acceptance inspection which Densitron is clearly responsible for, return them to Densitron.

Both Densitron and customer should analyse the reason and discuss the handling of non-conforming displays when the reason is not clear.

Equally, both sides should discuss and come to agreement for issues pertaining to modification of Densitron quality assurance standard.

7 RELIABILITY SPECIFICATION

7.1 RELIABILITY TESTS

Test Item		Test Condition	
Durability Test	High Temperature Storage	Ta= 90°C	96h
	Low Temperature Storage	Ta= -40°C	96h
	Temperature Cycle Storage	-30°C \leftrightarrow 85°C ON/OFF, 20 cycles. ON time over 10 seconds ,OFF time over 10 seconds	
	High Temperature Operation	Tp= 85°C	96h
	Low Temperature Operation	Tp= -30°C	96h
	High Temperature & Humidity Operation	Tp= 60°C RH= 70% 96h Non condensing	
	ESD Test	150Pf, 330Ω, ±6KV (Contact)/±8KV (Air), 5 Points/panel, 10 times/point	
	Thermal Shock Resistance	The sample should be allowed to stand the following 5 cycles of operation: TSTL for 30 minutes -> normal temperature for 5 minutes -> TSTH for 30 minutes -> normal temperature for 5 minutes, as one cycle, then taking it out and drying it at normal temperature, and allowing it stand for 24 hours	
	Box Drop Test	1 Corner 3 Edges 6 faces, 66 cm (Medium Box)	

Note: Ta=ambient temperature Tp= Panel temperature

Notes:

1. No dew condensation to be observed.
2. The function test shall be conducted after 4 hours storage at the normal temperature and humidity after removed from the test chamber.
3. No cosmetic or functional defects should be allowed.
4. Total current consumption should be less than twice the initial value.

8 HANDLING PRECAUTIONS

Safety

If the LCD panel breaks, be careful not to get the liquid crystal fluid in your mouth or in your eyes. If the liquid crystal touches your skin or clothes, wash it off immediately using soap and plenty of water.

Mounting and Design

Place a transparent plate (e.g. acrylic, polycarbonate or glass) on the display surface to protect the display from external pressure. Leave a small gap between the transparent plate and the display surface.

When assembling with a zebra connector, clean the surface of the pads with alcohol and keep the surrounding air very clean.

Design the system so that no input signal is given unless the power supply voltage is applied.

Caution during LCD cleaning

Lightly wipe the display surface with a soft cloth soaked with Isopropyl alcohol, Ethyl alcohol or Trichlorotrifluoroethane.

Do not wipe the display surface with dry or hard materials that will damage the polariser surface. Do not use aromatic solvents (toluene and xylene), or ketonic solvents (ketone and acetone).

Caution against static charge

As the display uses C-MOS LSI drivers, connect any unused input terminal to VDD or VSS. Do not input any signals before power is turned on. Also, ground your body, work/assembly table and assembly equipment to protect against static electricity.

Packaging

Displays use LCD elements, and must be treated as such. Avoid strong shock and drop from a height. To prevent displays from degradation, do not operate or store them exposed directly to sunshine or high temperature/humidity.

Caution during operation

It is indispensable to drive the display within the specified voltage limit since excessive voltage shortens its life. Direct current causes an electrochemical reaction with remarkable deterioration of the display quality. Give careful consideration to prevent direct current during ON/OFF timing and during operation. Response time is extremely delayed at temperatures lower than the operating temperature range while, at high temperatures, displays become dark. However, this phenomenon is reversible and does not mean a malfunction or a display that has been permanently damaged. If the display area is pushed on hard during operation, some graphics will be abnormally displayed but returns to a normal condition after turning off the display once. Even a small amount of condensation on the contact pads (terminals) can cause an electro-chemical reaction which causes missing rows and columns. Give careful attention to avoid condensation.

Storage

Store the display in a dark place where the temperature is $25^{\circ}\text{C} \pm 10^{\circ}\text{C}$ and the humidity below 50%RH. Store the display in a clean environment, free from dust, organic solvents and corrosive gases.

Do not crash, shake or jolt the display (including accessories).

Product No.	DMT070WVNTNT0-1A	REV. 1.0
-------------	------------------	----------

Page	23 / 23
------	---------