



Is Now Part of



ON Semiconductor®

To learn more about ON Semiconductor, please visit our website at
www.onsemi.com

Please note: As part of the Fairchild Semiconductor integration, some of the Fairchild orderable part numbers will need to change in order to meet ON Semiconductor's system requirements. Since the ON Semiconductor product management systems do not have the ability to manage part nomenclature that utilizes an underscore (_), the underscore (_) in the Fairchild part numbers will be changed to a dash (-). This document may contain device numbers with an underscore (_). Please check the ON Semiconductor website to verify the updated device numbers. The most current and up-to-date ordering information can be found at www.onsemi.com. Please email any questions regarding the system integration to Fairchild_questions@onsemi.com.

ON Semiconductor and the ON Semiconductor logo are trademarks of Semiconductor Components Industries, LLC dba ON Semiconductor or its subsidiaries in the United States and/or other countries. ON Semiconductor owns the rights to a number of patents, trademarks, copyrights, trade secrets, and other intellectual property. A listing of ON Semiconductor's product/patent coverage may be accessed at www.onsemi.com/site/pdf/Patent-Marking.pdf. ON Semiconductor reserves the right to make changes without further notice to any products herein. ON Semiconductor makes no warranty, representation or guarantee regarding the suitability of its products for any particular purpose, nor does ON Semiconductor assume any liability arising out of the application or use of any product or circuit, and specifically disclaims any and all liability, including without limitation special, consequential or incidental damages. Buyer is responsible for its products and applications using ON Semiconductor products, including compliance with all laws, regulations and safety requirements or standards, regardless of any support or applications information provided by ON Semiconductor. "Typical" parameters which may be provided in ON Semiconductor data sheets and/or specifications can and do vary in different applications and actual performance may vary over time. All operating parameters, including "Typicals" must be validated for each customer application by customer's technical experts. ON Semiconductor does not convey any license under its patent rights nor the rights of others. ON Semiconductor products are not designed, intended, or authorized for use as a critical component in life support systems or any FDA Class 3 medical devices or medical devices with a same or similar classification in a foreign jurisdiction or any devices intended for implantation in the human body. Should Buyer purchase or use ON Semiconductor products for any such unintended or unauthorized application, Buyer shall indemnify and hold ON Semiconductor and its officers, employees, subsidiaries, affiliates, and distributors harmless against all claims, costs, damages, and expenses, and reasonable attorney fees arising out of, directly or indirectly, any claim of personal injury or death associated with such unintended or unauthorized use, even if such claim alleges that ON Semiconductor was negligent regarding the design or manufacture of the part. ON Semiconductor is an Equal Opportunity/Affirmative Action Employer. This literature is subject to all applicable copyright laws and is not for resale in any manner.

BAT42XV2-BAT43XV2 Schottky Barrier Diodes

Features

- Low Forward Voltage Drop
- Flat Lead, Surface Mount Device at 0.60mm Height
- Extremely Small Outline Plastic Package SOD523F
- Moisture Level Sensitivity 1
- Pb-free Version and RoHS Compliant
- Matte Tin (Sn) Lead Finish
- Green Mold Compound

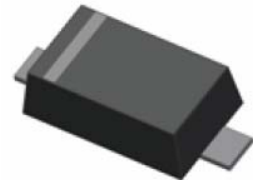
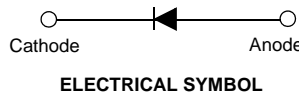

BAT42XV2 Marking : 6B
BAT43XV2 Marking : 7B

SOD-523F
Band Indicates Cathode

Absolute Maximum Ratings * $T_A=25^\circ\text{C}$ unless otherwise noted

| Symbol | Parameter | Value | Units |
|-------------|------------------------------------|-------------|------------------|
| V_{RRM} | Maximum Repetitive Reverse Voltage | 30 | V |
| V_R | Maximum DC Blocking Voltage | 30 | V |
| $I_{F(AV)}$ | Average Rectified Forward Current | 200 | mA |
| I_{FSM} | Peak Forward Surge Current | 4 | A |
| T_J | Operating Junction Temperature | +125 | $^\circ\text{C}$ |
| T_{STG} | Storage Temperature Range | -65 to +125 | $^\circ\text{C}$ |

* These ratings are limiting values above which the serviceability of any semiconductor device may be impaired.

Thermal Characteristics $T_A=25^\circ\text{C}$ unless otherwise noted

| Symbol | Parameter | Value | Units |
|-----------------|---|-------|---------------------------|
| P_D | Power Dissipation | 200 | mW |
| $R_{\theta JA}$ | Thermal Resistance, Junction to Ambient | 500 | $^\circ\text{C}/\text{W}$ |

* Device mounted on FR-4 PCB minimum land pad.

Electrical Characteristics $T_A=25^\circ\text{C}$ unless otherwise noted

| Symbol | Parameter | Test Condition | Min. | Typ. | Max. | Units |
|----------|-------------------------|---|------|------|-------------------------------------|-------|
| BV_R | Breakdown Voltage | $I_R=100\mu\text{A}$ | 30 | | | V |
| I_R | Reverse Leakage Current | $V_R=25\text{V}$ | | | 500 | nA |
| V_F | Forward Voltage | BAT42XV2 $I_F=10\text{mA}$ $I_F=50\text{mA}$ BAT43XV2 $I_F=2\text{mA}$ $I_F=15\text{mA}$ BAT42XV2, BAT43XV2 $I_F=200\text{mA}$ | 0.26 | | 0.40 0.65 0.33 0.45 1.0 | V |
| T_{RR} | Reverse Recovery Time | $I_F=I_R=10\text{mA}$ $R_L=100\Omega$ $I_{RR}=1\text{mA}$ | | 5 | | nS |
| C | Capacitance | $V_R=1\text{V}$, $f=1\text{MHz}$ | | 7 | | pF |

Typical Performance Characteristics

Reverse Current vs Reverse Voltage

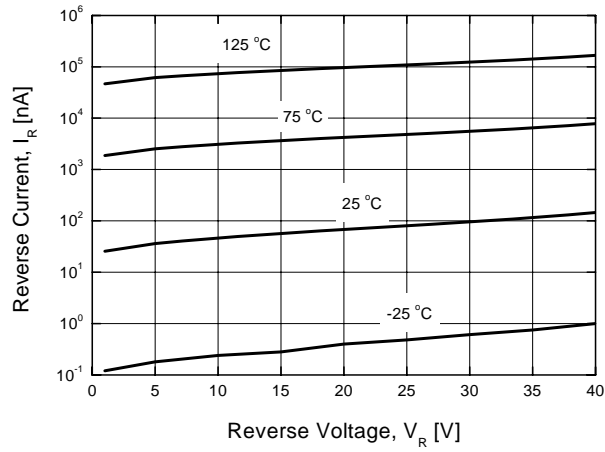

Forward Voltage vs Forward Current

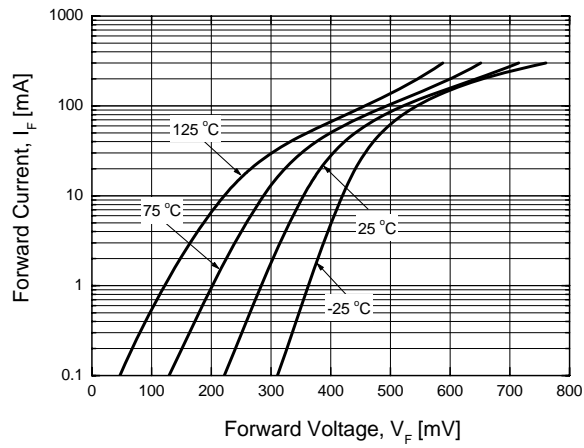

Typical Performance Characteristics (Continued)

Total Capacitance

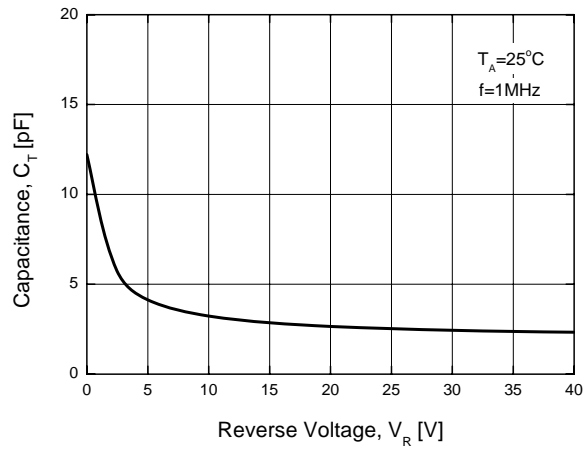

Power Derating Curve

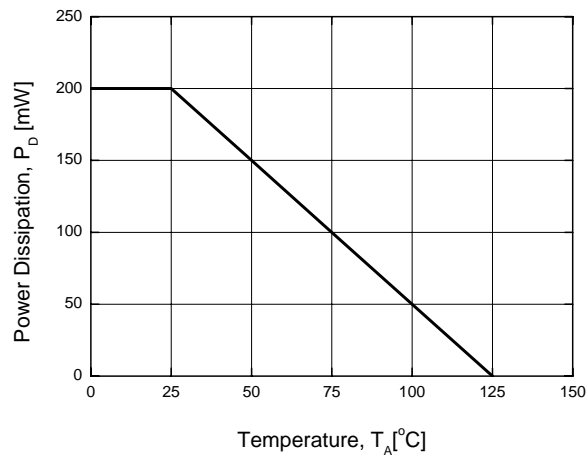

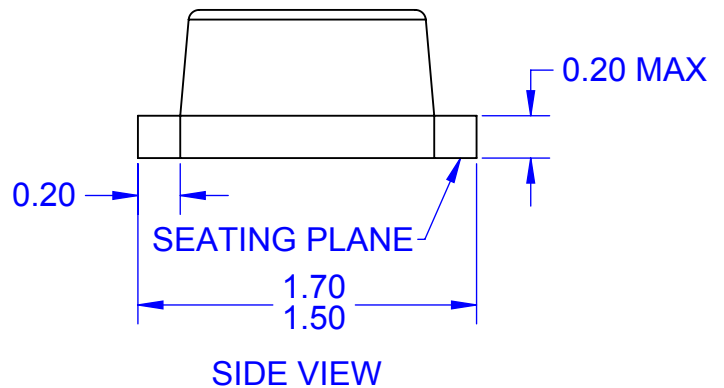
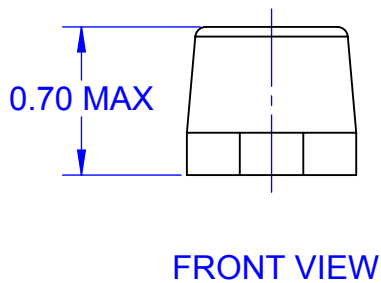
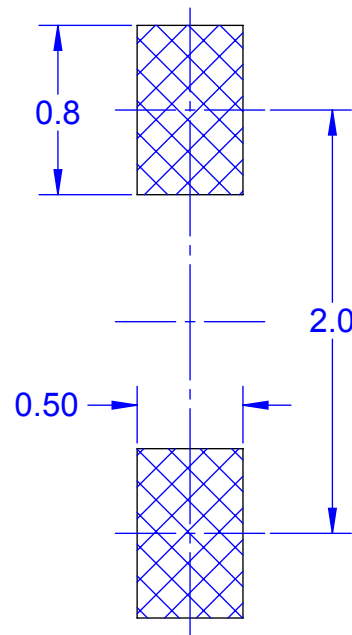
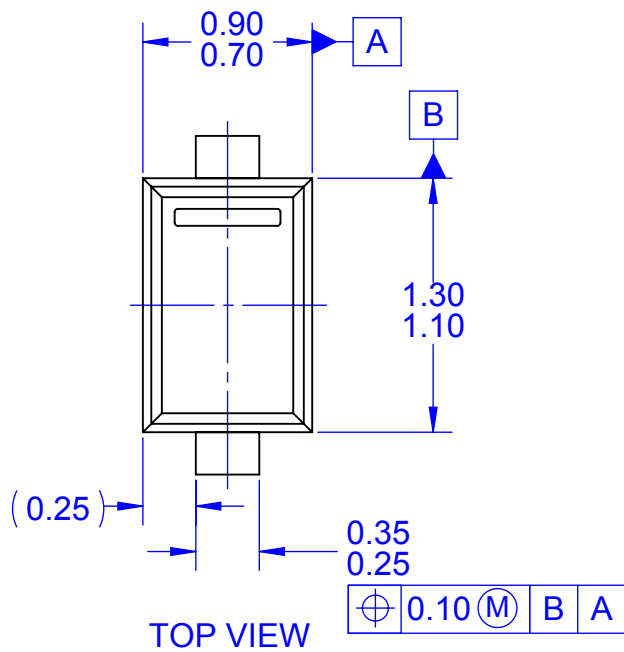

NOTES:

- A. CONFORMS TO JEITA SC-79
- B. ALL DIMENSIONS ARE IN MILLIMETERS
- C. DRAWING CONFORMS TO ASME Y14.5M-2009
- D. DIMENSIONS ARE EXCLUSIVE OF BURRS, MOLD FLASH, AND TIE BAR PROTRUSIONS.
- E. LAND PATTERN RECOMMENDATION IS BASED ON IPC7351A STANDARD SOD1609X65M
- F. DRAWING FILENAME: MKT-SOD523F1rev2



ON Semiconductor and  are trademarks of Semiconductor Components Industries, LLC dba ON Semiconductor or its subsidiaries in the United States and/or other countries. ON Semiconductor owns the rights to a number of patents, trademarks, copyrights, trade secrets, and other intellectual property. A listing of ON Semiconductor's product/patent coverage may be accessed at www.onsemi.com/site/pdf/Patent-Marking.pdf. ON Semiconductor reserves the right to make changes without further notice to any products herein. ON Semiconductor makes no warranty, representation or guarantee regarding the suitability of its products for any particular purpose, nor does ON Semiconductor assume any liability arising out of the application or use of any product or circuit, and specifically disclaims any and all liability, including without limitation special, consequential or incidental damages. Buyer is responsible for its products and applications using ON Semiconductor products, including compliance with all laws, regulations and safety requirements or standards, regardless of any support or applications information provided by ON Semiconductor. "Typical" parameters which may be provided in ON Semiconductor data sheets and/or specifications can and do vary in different applications and actual performance may vary over time. All operating parameters, including "Typicals" must be validated for each customer application by customer's technical experts. ON Semiconductor does not convey any license under its patent rights nor the rights of others. ON Semiconductor products are not designed, intended, or authorized for use as a critical component in life support systems or any FDA Class 3 medical devices or medical devices with a same or similar classification in a foreign jurisdiction or any devices intended for implantation in the human body. Should Buyer purchase or use ON Semiconductor products for any such unintended or unauthorized application, Buyer shall indemnify and hold ON Semiconductor and its officers, employees, subsidiaries, affiliates, and distributors harmless against all claims, costs, damages, and expenses, and reasonable attorney fees arising out of, directly or indirectly, any claim of personal injury or death associated with such unintended or unauthorized use, even if such claim alleges that ON Semiconductor was negligent regarding the design or manufacture of the part. ON Semiconductor is an Equal Opportunity/Affirmative Action Employer. This literature is subject to all applicable copyright laws and is not for resale in any manner.

PUBLICATION ORDERING INFORMATION

LITERATURE FULFILLMENT:

Literature Distribution Center for ON Semiconductor
19521 E. 32nd Pkwy, Aurora, Colorado 80011 USA
Phone: 303-675-2175 or 800-344-3860 Toll Free USA/Canada
Fax: 303-675-2176 or 800-344-3867 Toll Free USA/Canada
Email: orderlit@onsemi.com

N. American Technical Support: 800-282-9855 Toll Free
USA/Canada
Europe, Middle East and Africa Technical Support:
Phone: 421 33 790 2910
Japan Customer Focus Center
Phone: 81-3-5817-1050

ON Semiconductor Website: www.onsemi.com
Order Literature: <http://www.onsemi.com/orderlit>
For additional information, please contact your local
Sales Representative