

1200 V power Schottky silicon carbide diode

Datasheet - production data

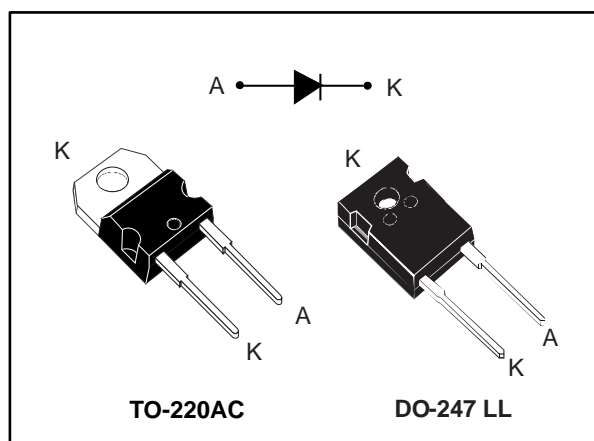

Description

The SiC diode, available in TO-220AC and TO-247LL, is an ultrahigh performance power Schottky rectifier. It is manufactured using a silicon carbide substrate. The wide band-gap material allows the design of a low V_F Schottky diode structure with a 1200 V rating.

Due to the Schottky construction, no recovery is shown at turn-off and ringing patterns are negligible. The minimal capacitive turn-off behavior is independent of temperature.

Especially suited for use in PFC and secondary side applications, this ST SiC diode will boost the performance in hard switching conditions. This rectifier will enhance the performance of the targeted application. Its high forward surge capability ensures a good robustness during transient phases.

Features

- No or negligible reverse recovery
- Switching behavior independent of temperature
- Robust high voltage periphery
- Operating from -40 °C to 175 °C
- Low V_F
- ECOPACK®2 compliant

Table 1: Device summary

Symbol	Value
$I_{F(AV)}$	15 A
V_{RRM}	1200 V
T_j (max.)	175 °C
V_F (typ.)	1.35 V

1 Characteristics

Table 2: Absolute ratings (limiting values at 25 °C, unless otherwise specified)

Symbol	Parameter		Value	Unit	
V _{RRM}	Repetitive peak reverse voltage (T _j = -40 °C to +175 °C)		1200	V	
I _{F(RMS)}	Forward rms current		38	A	
I _{F(AV)}	Average forward current	TO-220AC, T _C = 155 °C ⁽¹⁾ , DC current	15	A	
		DO-247 LL, T _C = 150 °C ⁽¹⁾ , DC current			
I _{FRM}	Repetitive peak forward current	TO-220AC, T _C = 155 °C, T _J = 175 °C, δ = 0.1	58	A	
		DO -247 LL, TC = 150 °C, T _J = 175 °C, δ = 0.1	61		
I _{FSM}	Surge non repetitive forward current	t _p = 10 ms sinusoidal	T _C = 25 °C	105	A
			T _C = 150 °C	90	
		t _p = 10 μs square	T _C = 25 °C	630	
T _{stg}	Storage temperature range		-65 to +175	°C	
T _j	Operating junction temperature range		-40 to +175	°C	

Notes:

⁽¹⁾Value based on R_{th(j-c)} max.

Table 3: Thermal parameters

Symbol	Parameter		Typ. value	Max. value	Unit
R _{th(j-c)}	Junction to case	TO-220AC	0.45	0.6	°C/W
		DO-247 LL	0.50	0.70	

Table 4: Static electrical characteristics

Symbol	Parameter	Test conditions		Min.	Typ.	Max.	Unit
I _R ⁽¹⁾	Reverse leakage current	T _j = 25 °C	V _R = V _{RRM}	-	7.5	90	μA
		T _j = 150 °C		-	45	600	
V _F ⁽²⁾	Forward voltage drop	T _j = 25 °C	I _F = 15 A	-	1.35	1.50	V
		T _j = 150 °C		-	1.75	2.25	

Notes:

⁽¹⁾Pulse test: t_p = 10 ms, δ < 2%

⁽²⁾Pulse test: t_p = 500 μs, δ < 2%

To evaluate the conduction losses use the following equation:

$$P = 1.09 \times I_{F(AV)} + 0.0775 \times I_{F(RMS)}^2$$

Table 5: Dynamic electrical characteristics

Symbol	Parameter	Test conditions	Min.	Typ.	Max.	Unit
$Q_{Cj}^{(1)}$	Total capacitive charge	$V_R = 800 \text{ V}$	-	94	-	nC
C_j	Total capacitance	$V_R = 0 \text{ V}, T_c = 25 \text{ }^\circ\text{C}, F = 1 \text{ MHz}$	-	1200	-	pF
		$V_R = 800 \text{ V}, T_c = 25 \text{ }^\circ\text{C}, F = 1 \text{ MHz}$	-	78	-	

Notes:

⁽¹⁾Most accurate value for the capacitive charge: $Q_{Cj} = \int_0^{V_{OUT}} C_j(V_R) \cdot dV_R$

1.1 Characteristics (curves)

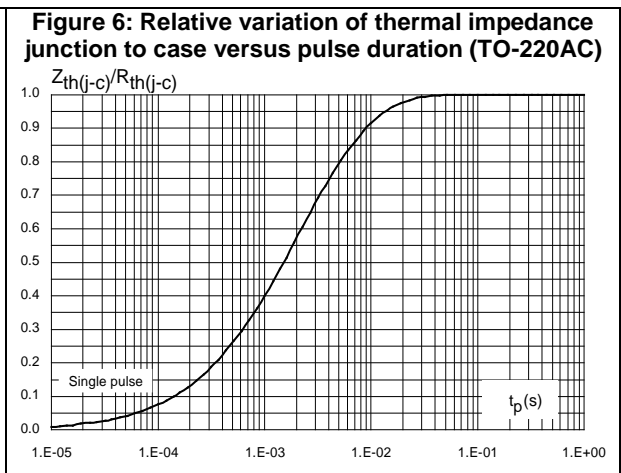
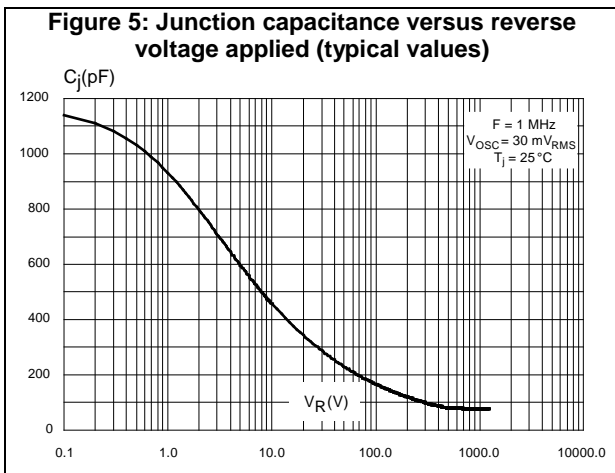
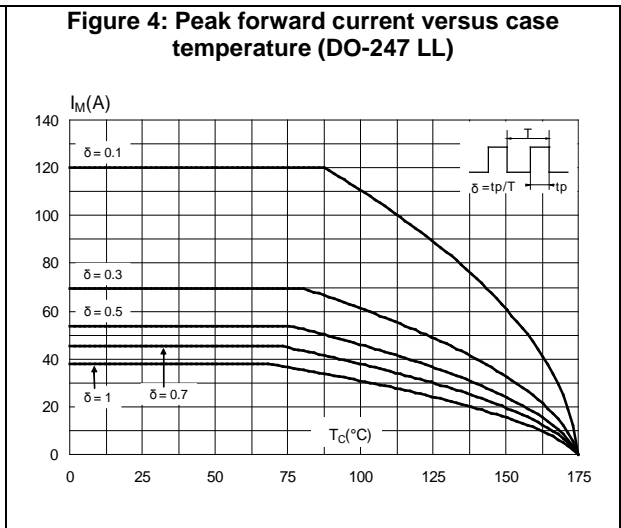
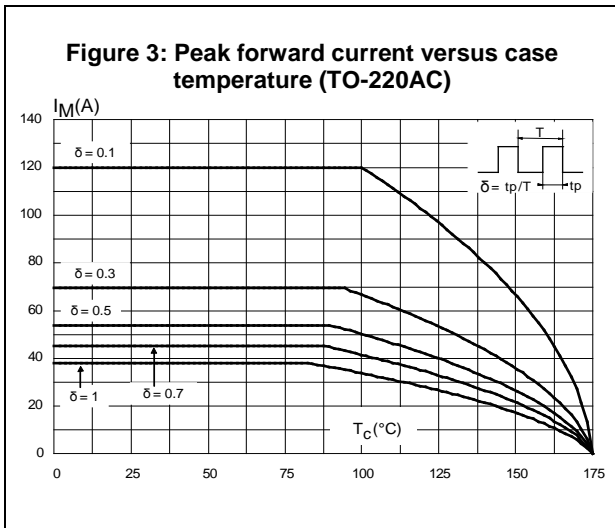
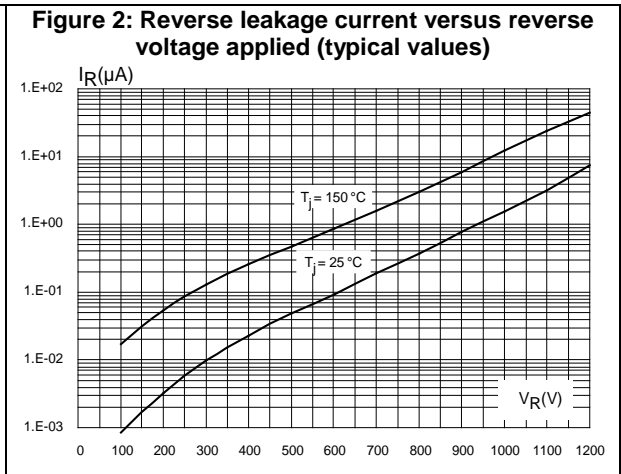
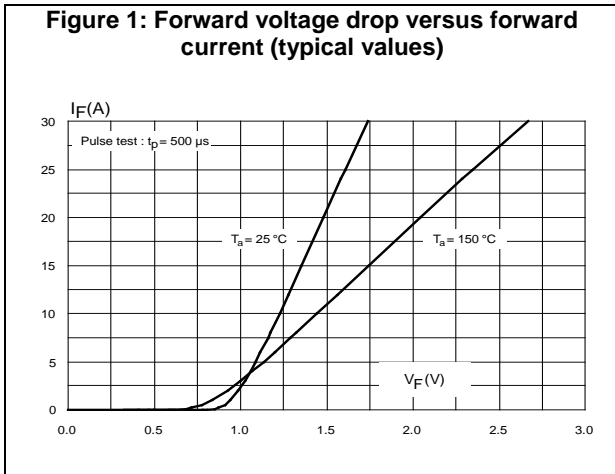

Figure 7: Relative variation of thermal impedance junction to case versus pulse duration (DO-247 LL)

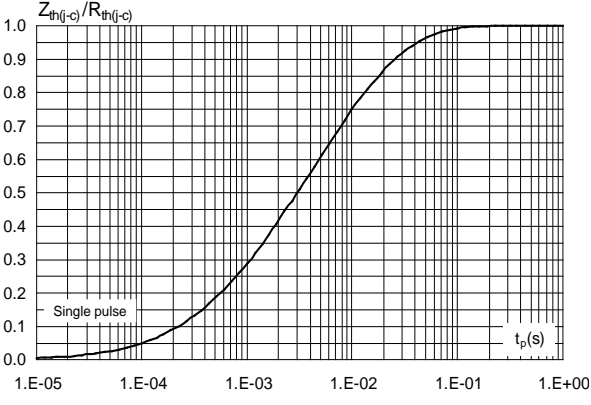

Figure 8: Non-repetitive peak surge forward current versus pulse duration (sinusoidal waveform)

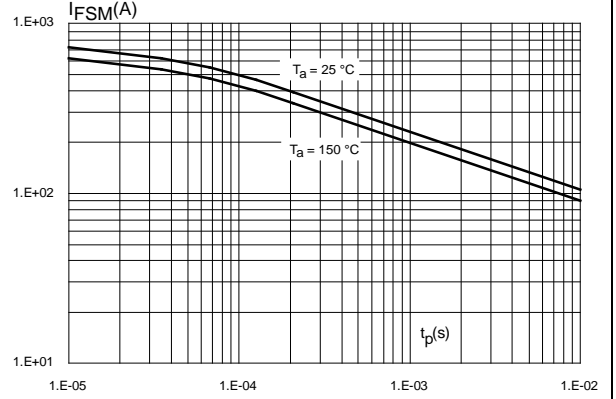
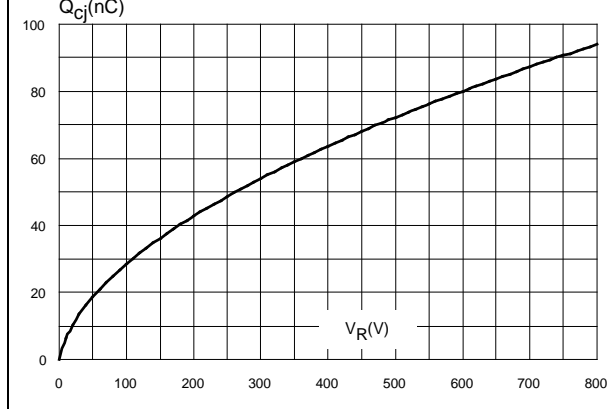

Figure 9: Total capacitive charges versus reverse voltage applied (typical values)



2 Package information

In order to meet environmental requirements, ST offers these devices in different grades of ECOPACK® packages, depending on their level of environmental compliance. ECOPACK® specifications, grade definitions and product status are available at: www.st.com. ECOPACK® is an ST trademark.

- Cooling method: by conduction (C)
- Epoxy meets UL94,V0
- Recommended torque value: 0.55 N·m (TO-220AC) and 0.8 N·m (DO-247 LL)
- Maximum torque value: 0.7 N·m (TO-220AC) and 1 N·m (DO-247 LL)

2.1 TO-220AC package information

Figure 10: TO-220AC package outline

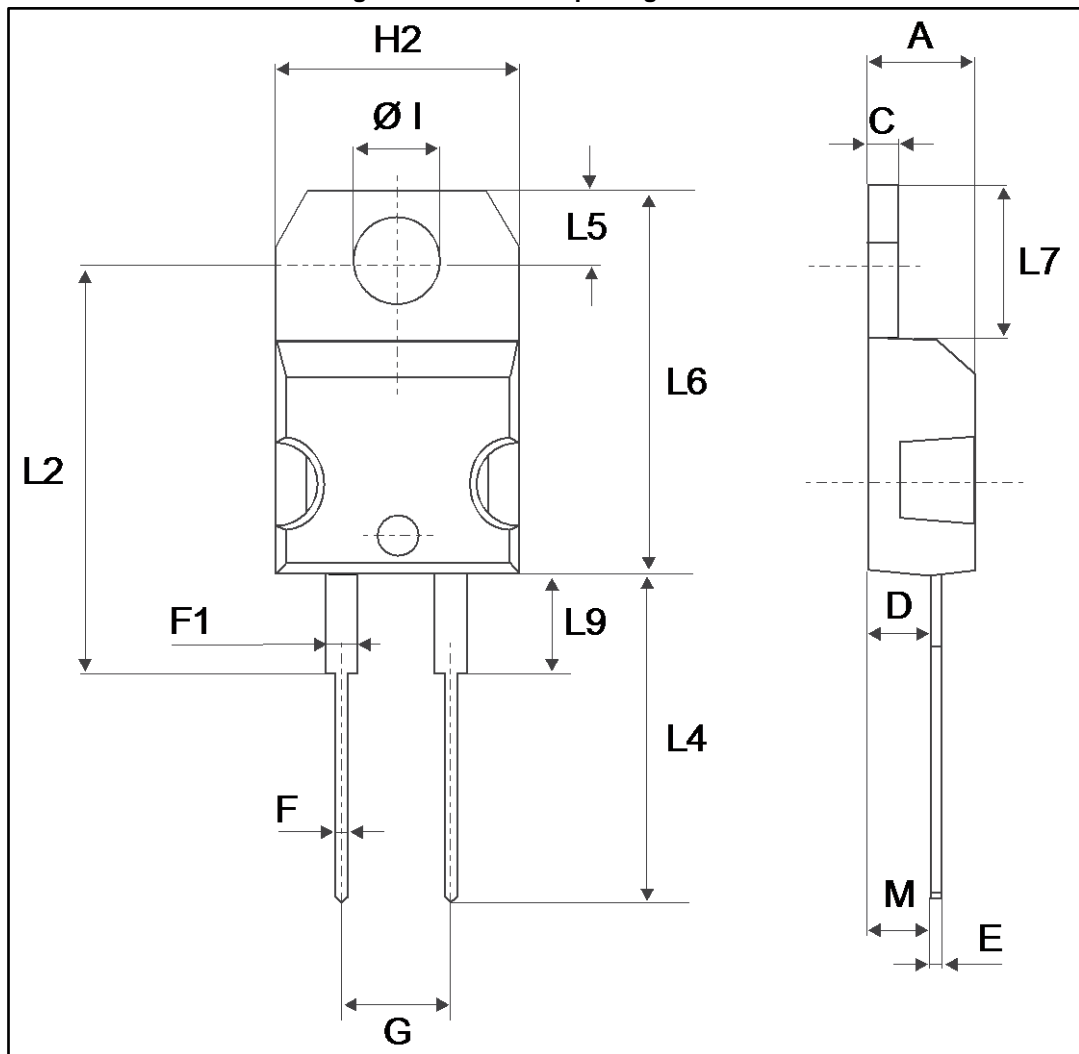

Table 6: TO-220AC package mechanical data

Ref.	Dimensions			
	Millimeters		Inches	
	Min.	Max.	Min.	Max.
A	4.40	4.60	0.173	0.181
C	1.23	1.32	0.048	0.051
D	2.40	2.72	0.094	0.107
E	0.49	0.70	0.019	0.027
F	0.61	0.88	0.024	0.034
F1	1.14	1.70	0.044	0.066
G	4.95	5.15	0.194	0.202
H2	10.00	10.40	0.393	0.409
L2	16.40 typ.		0.645 typ.	
L4	13.00	14.00	0.511	0.551
L5	2.65	2.95	0.104	0.116
L6	15.25	15.75	0.600	0.620
L7	6.20	6.60	0.244	0.259
L9	3.50	3.93	0.137	0.154
M	2.6 typ.		0.102 typ.	
Diam	3.75	3.85	0.147	0.151

2.2 DO-247 LL package information

Figure 11: DO-247 LL package outline

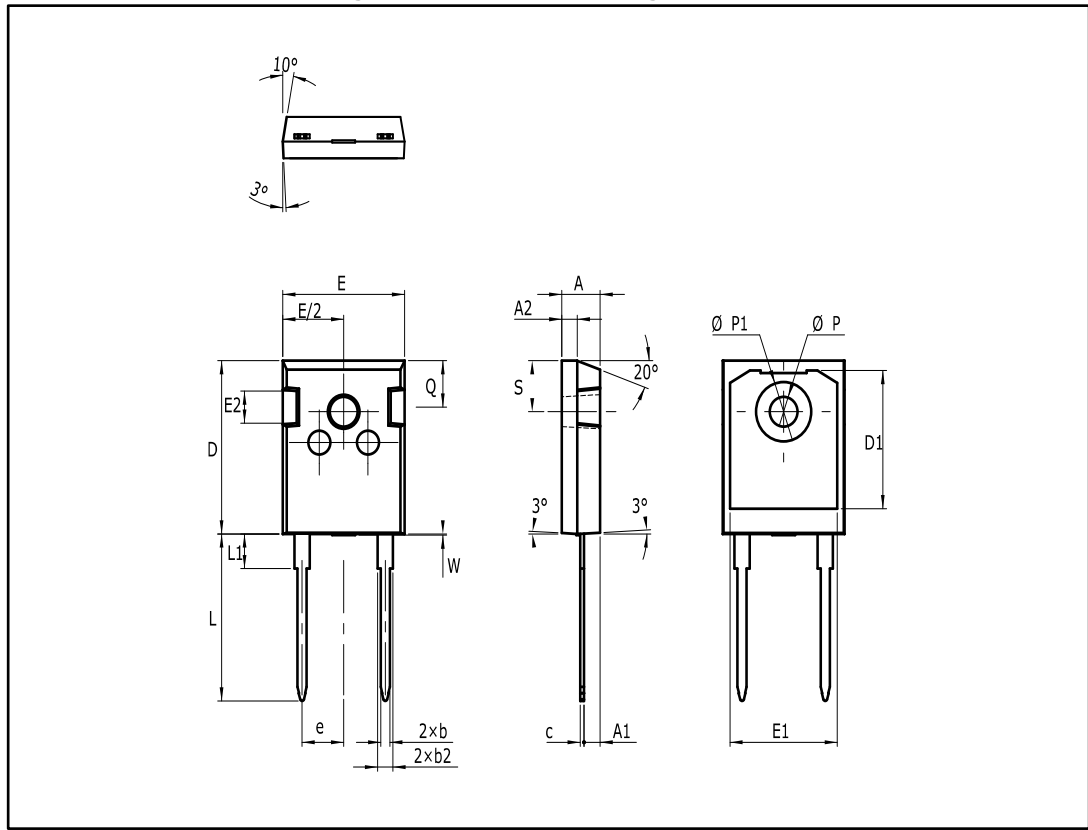

Table 7: DO-247 LL package mechanical data

Ref.	Dimensions			
	Millimeters		Inches ⁽¹⁾	
	Min.	Max.	Min.	Max.
A	4.70	5.31	0.185	0.209
A1	2.21	2.59	0.087	0.102
A2	1.50	2.49	0.059	0.098
b	0.99	1.40	0.039	0.055
b2	1.65	2.39	0.065	0.094
c	0.38	0.89	0.015	0.035
D	20.80	21.46	0.819	0.845
D1	13.08		0.515	
E	15.49	16.26	0.610	0.640
e	5.44 typ.		0.214	
E1	13.46		0.530	
E2	3.43	3.99	0.135	0.157
L	19.81	20.32	0.780	0.800
L1		4.50		0.177
P	3.56	3.66	0.140	0.144
P1	7.06	7.39	0.278	0.291
Q	5.38	6.20	0.219	0.244
S	6.17 typ.		0.243	
W		0.15		0.006

Notes:⁽¹⁾Inches dimensions given for reference only

3 Ordering information

Table 8: Ordering information

Order code	Marking	Package	Weight	Base qty.	Delivery mode
STPSC15H12D	STPSC15H12D	TO-220AC	1.86 g	50	Tube
STPSC15H12WL	STPSC15H12WL	DO-247 LL	5.9 g	30	Tube

4 Revision history

Table 9: Document revision history

Date	Revision	Changes
10-May-2016	1	Initial version
05-Sept-2017	2	Added DO-247 LL package. Updated Section "Features" , Section 1: "Characteristics" and Table 8: "Ordering information" .

IMPORTANT NOTICE – PLEASE READ CAREFULLY

STMicroelectronics NV and its subsidiaries ("ST") reserve the right to make changes, corrections, enhancements, modifications, and improvements to ST products and/or to this document at any time without notice. Purchasers should obtain the latest relevant information on ST products before placing orders. ST products are sold pursuant to ST's terms and conditions of sale in place at the time of order acknowledgement.

Purchasers are solely responsible for the choice, selection, and use of ST products and ST assumes no liability for application assistance or the design of Purchasers' products.

No license, express or implied, to any intellectual property right is granted by ST herein.

Resale of ST products with provisions different from the information set forth herein shall void any warranty granted by ST for such product.

ST and the ST logo are trademarks of ST. All other product or service names are the property of their respective owners.

Information in this document supersedes and replaces information previously supplied in any prior versions of this document.

© 2017 STMicroelectronics – All rights reserved