

ITT Cannon DL Series ZIF Connectors

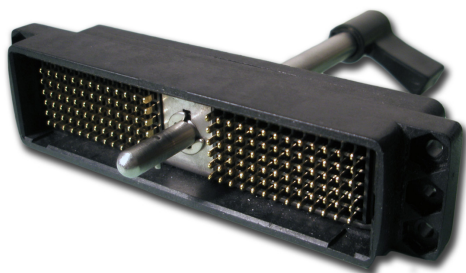

HIGH-DENSITY ZIF CONNECTORS

ITT Cannon DL series connectors are versatile, high-density ZIF connectors (zero-insertion force) with 60 contact, 96 contact and 156 contact versions. DL series ZIF connectors are excellent medical connectors and are suited for other applications requiring no sliding force during mating and unmating, such as sound, lighting and entertainment equipment. The new ITT Cannon DLM shielded metal connector offers a stronger, light-weight aluminum housing that is nickel-plated for maximum shielding. For more details on the ITT Cannon DL series of zero-insertion force (ZIF) connectors, please see the product specifications below.

APPLICATIONS

MEDICAL

- Ultrasound diagnostic
- Patient monitoring
- Hospital equipment

TEST & INSTRUMENTATION

- Avionics
- Automated test equipment
- Computer & peripheral equipment
- Semiconductor

COMMERCIAL/INDUSTRIAL MANUFACTURING

- Automation
- Robotics
- Electrical controls

ENTERTAINMENT

- Recording studio equipment
- Stage lighting & sound
- Broadcasting equipment

TELECOMMUNICATION

- Systems interconnect
- Manufacturing test equipment
- Switching systems

TRANSPORTATION

- Locomotive systems
- Automotive electronics
- Aircraft simulators

FEATURES

TRUE ZERO INSERTION FORCE (ZIF) CONNECTORS

There is no build up of mating force typically associated with high pin count style connectors, so mating and un-mating is as easy as twisting a handle.

LONG MATING LIFE

10,000 matings minimum allows these connectors to be used in testing and burn-in applications.

HIGH PIN COUNT

60, 96, 156, 260, 360, 624, 1248 and even 2496 contacts make the DL series one of the highest pin count per connector series available.

WIDE SELECTION OF TERMINATIONS

Crimp, printed circuit, square post and solder buss style contacts give you maximum flexibility to wire your connectors.

NEW NICKEL-PLATED ALUMINUM HOUSINGS

The DLM1/2/3 (60, 96 & 156 pin) versions are now available in a strong metal shell, fully EMI/RFI-shielded version that can mate with the standard plastic housing version. This allows for easy upgrade to a shielded version without sacrificing intermatability of units already in the field.

CONTACT WIPING

During mating, the contacts wipe lightly together, which helps clean the contact mating area and assures low contact resistance needed for digital or low current applications.

MATERIALS & FINISHES

Shells	DL1/2/3	Glass-filled thermoplastic, UL94V1-rated, Color: black
	DL4	Aluminum alloy, cadmium-plated housing, clear anodized mounting plate
	DL5	Glass-filled thermoplastic, UL94V0-rated, Color: black
	DLM1/2/3/5/6	Aluminum alloy, nickel-plated
Actuators & Plug Insert Retainers		Stainless steel, passivated
Contacts		Copper alloy
Plating	Crimp	50μ inches gold over 50μ inches nickel mating area gold flash on balance
	Crimp	20μ inches gold over 50μ inches nickel mating area tin lead on balance
	Square Post	50μ inches gold over 50μ inches nickel mating area gold flash on balance
	Square Post	20μ inches gold over 50μ inches nickel mating area gold flash on balance
	PC/RC	20μ inches gold over 50μ inches nickel mating area tin lead on balance
Insulators	DL4	Glass-filled thermoplastic, UL94V1-rated, Color: grey
	DLM1/2/3/5/6	Glass-filled thermoplastic, UL94V0-rated, Color: black

ELECTRICAL DATA

Dielectric Withstanding Voltage	1200 Vac RMS – Crimp & square post contacts
	1000 Vac RMS – PC/RC round PCB contacts
	750 Vac RMS – DL4
Current Rating	5 Amps maximum – Crimp & square post contacts
	4 Amps maximum – PC/RC contact
	10 Amps up to 60 Amps maximum for buss contacts

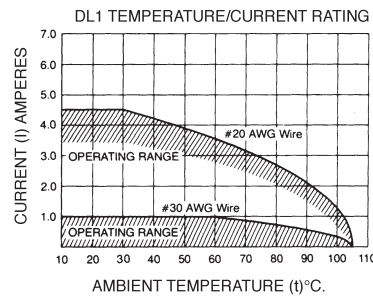
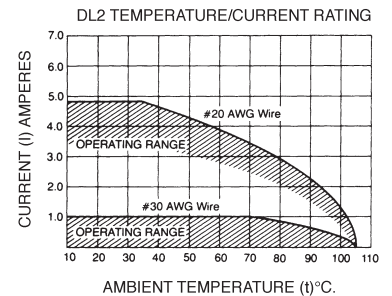
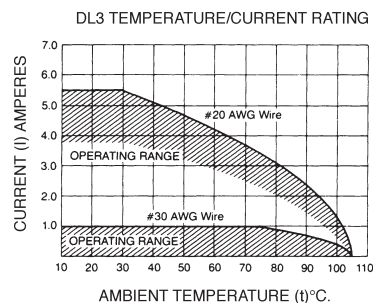
DL1
DLM1DL2
DLM2DL3
DLM3

DL4

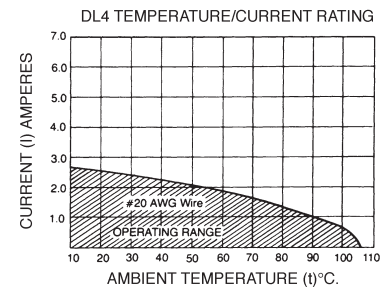

Wire Range Sizes	32 AWG – 18 AWG
Contact Resistance	15 milliohms maximum – Crimp & square post contacts 20 milliohms maximum – Crimp 32-30 AWG contacts 30 milliohms maximum – PC/RC contacts
Insulation Resistance	5000 megohms minimum

NOTE: The Ambient Temperature Curves shown represent the rated current carrying capacity of the Cannon DL1/2/3/4 and DLM1/2/3 electrical connectors, derated to 80% of the value recorded using the methods specified by International Electro-Technical Commission Document 48 (1975).

Current was applied to the total connector (all contacts) in one-half ampere increments and maintained at each current level until thermal stability was achieved. A thermocouple inserted into the "hottest area" of each connector then measured the connector temperature at the same time that an ambient temperature reading was taken. The difference between the two measured values is the heat rise or self-heating created solely by the current flow; this temperature rise for the current level was deducted from the insulator material rated temperature. These values were then derated to 80% to obtain the curves shown.

TECH SPECS





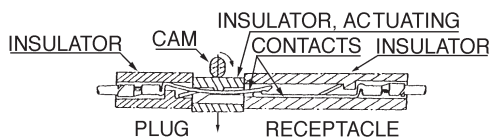
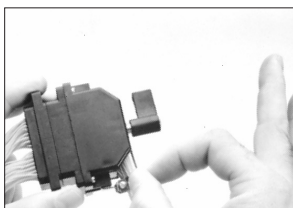
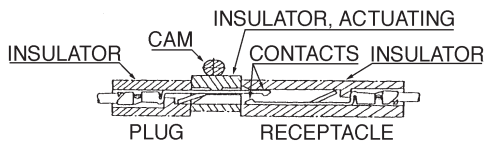
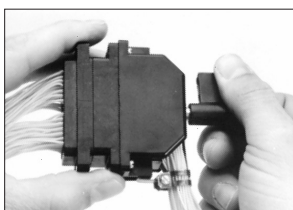
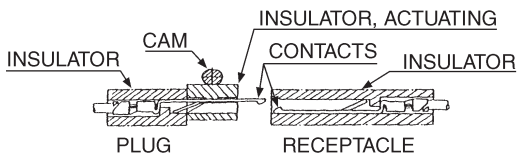
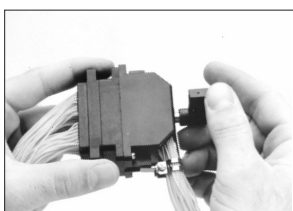

MECHANICAL

Operating Temperature	-55°C to 105°C; DL4 -55°C to 71°C	
Durability	10,000 Mating cycles minimum DL/DLM 20,000 Mating cycles minimum DL4	
Insulation Strip Length	32 to 22 AWG .130" (3.30mm) 20 to 18 AWG .160" (4.06mm)	
Insulation Diameter	30 to 28 AWG .053" (1.35mm) maximum 26 to 24 AWG .065" (1.65mm) maximum 22 to 18 AWG .074" (1.88mm) maximum	
Crimp Tensile Strength min. lbs.	AWG	Lbs.
	32	1
	30	1.5
	28	3
	26	10
	24	15
	22	15
20	19	
18	30	
Chemical Resistance	Salt spray per MIL-STD-202 method 101 Condition B (48 hours)	
Vibration	Per MIL-STD-202 method 204 Condition C Per MIL-STD-167-1/2 Modified (DL4)	
Shock	Per MIL-STD-202 method 213 Condition A (50g's)	
Contact Type	Crimp, wire wrap, printed circuit board, buss contacts - solder or crimp lug tab	
Number of Circuits	60 to 2496	
Contact Insertion	Hand-insertable from rear, no insertion tool required	
Contact Retention	8 lbs. (35.585 newtons) minimum	
Contact Spacing	.100" (25.4mm) square grid	
Polarization	By center and/or corner polarizing post kit	
Approvals	UL94V1 and UL94V0 materials	



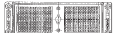



HOW DL/DLM HAND-ACTUATED CONNECTORS WORK



PLUGS

NUMBER OF CONTACTS	PC TAIL .280" (7.11MM) SQUARE .025" (.64MM)				PC TAIL ROUND .280" (7.11MM) DIA. .020" (.50MM)
	NON-SHIELDED		SHIELDED		
	50µ" GOLD	20µ" GOLD	50µ" GOLD	20µ" GOLD	20µ" GOLD
 60	-	Contact us	DLM3-60PW6A 112138-0000	DLM3-60PW6 112138-0001	DLM3-60PC 127050-0223
 96	DL2-96PW6A 110777-0025	Contact us	DLM2-96PW6A 112136-0000	DLM2-96PW6 112136-0001	DLM2-96PC 127050-0215
 156	DL1-156PW6A 110535-0030	DL1-156PW6 110535-0026	DLM1-156PW6A 112134-0000	DLM1-156PW6 112134-0001	DLM1-156PC 127050-0207
 260	DL5-260PW6A 111986-0000	Contact us	DLM5-260PW6A 112086-0000	DLM5-260PW6 112086-0002	DLM5-260PC 127050-0111
 360	Contact us	Contact us	DLM6-360PW6A 111995-0000	DLM6-360PW6 111995-0001	DLM6-360PC 127050-0097
 624	DL4-624PW6A 110959-0042	Contact us	-	-	-
 1248	Contact us	Contact us	-	-	-
 2496	Contact us	Contact us	-	-	-

RECEPTACLES

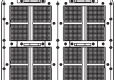
NUMBER OF CONTACTS	PC TAIL .280" (7.11MM) SQUARE .025" (.64MM)				PC TAIL ROUND .280" (7.11MM) DIA. .020" (.50MM)
	NON-SHIELDED		SHIELDED		
	50µ" GOLD	20µ" GOLD	50µ" GOLD	20µ" GOLD	20µ" GOLD
 60	DL3-60RW6B 110901-0010	Contact us	DLM3-60RW6B 112139-0000	-	DLM3-60RC 127050-0227
 96	DL2-96RW6B 110855-0014	Contact us	DLM2-96RW6B 112137-0000	-	DLM2-96RC 127050-0366
 156	DL1-156RW6B 110536-1007	DL1-156RW6 110536-1009	DLM1-156RW6B 112135-0000	-	DLM1-156RC 127050-0211
 260	DL5-260RW6B 111987-0000	Contact us	DLM5-260RW6B 112087-0000	-	DLM5-260RC 127050-0112
 360	Contact us	Contact us	DLM6-360RW6B 111996-0001	-	DLM6-360RC 127050-0098
 624	DL4-624RW6B 110960-0048	Contact us	-	-	-
 1248	Contact us	Contact us	-	-	-
 2496	Contact us	Contact us	-	-	-

PLUGS

NUMBER OF CONTACTS	PC WIRE WRAP/PC TAIL .605" (15.37 MM) SQUARE .025" (.64MM)			PC WIRE WRAP/TAI LENGTH .125" (3.18MM) SQUARE .025" (.64MM)		FOR CRIMP AND INSERT CONTACTS	
	NON-SHIELDED		SHIELDED 50 50µ" GOLD	NON SHIELDED 50 50µ" GOLD	SHIELDED 50 50µ" GOLD	NON-SHIELDED	SHIELDED
	50µ" GOLD	20µ" GOLD					
60	DL3-60PW4A 110900-0013	DL3-60PW4 110900-0006	DLM3-60PW4A 112138-0001	Contact us	DLM3-60P w/.125 112138-0002	DL3-60P 110900-0008	DLM3-60P 127050-0220
96	DL2-96PW4A 110777-0022	DL2-96PW4 110777-0008	DLM2-96PW4A 112136-0001	Contact us	DLM2-96P w/.125 112136-0002	DL2-96P 110777-0000	DLM2-96P 127050-0212
156	DL1-156PW4A 110535-0025	DL1-156PW4 110535-0012	DLM1-156PW4A 112134-0001	DL1-156P w/.125 110535-0040	DLM1-156P w/.125 112134-0002	DL1-156P 110535-0000	DLM1-156P 127050-0204
260	DL5-260PW4A 111986-0003	Contact us	DLM5-260PW4A 112086-0002	Contact us	DLM5-260P w/.125 112086-0003	DL5-260P 111986-0014	DLM5-260P 127050-0109
360	-	Contact us	DLM6-360PW4A 111995-0001	Contact us	DLM6-360P w/.125 111995-0007	-	DLM6-360P 127050-0034
624	DL4-624PW4A 110959-0035	DL4-624PW4 110959-0011	-	Contact us	-	DL4-624P 110959-0002	-
1248	Contact us	Contact us	-	Contact us	-	DL4-1248P 110959-0003	-
2496	Contact us	Contact us	-	Contact us	-	DL4-2496P 110959-0004	-

RECEPTACLES

NUMBER OF CONTACTS	PC WIRE WRAP/PC TAIL .605" (15.37 MM) SQUARE .025" (.64MM)			PC WIRE WRAP /TAIL LENGTH .125" (3.18MM) SQUARE .025" (.64MM)		FOR CRIMP AND INSERT CONTACTS	
	NON-SHIELDED		SHIELDED 50µ" GOLD	NON-SHIELDED 50µ" GOLD	SHIELDED 50µ" GOLD	NON-SHIELDED	SHIELDED
	50µ" GOLD	20µ" GOLD					
60	DL3-60RW4B 110901-0009	DL3-60RW4 110901-0004	DLM3-60RW4B 112139-0001	Contact Us	DLM3-60R w/.125 112139-0002	DL3-60R 086-0032-000	DLM3-60R 127050-0224
96	DL2-96RW4B 110855-0013	DL2-96RW4 110855-0008	DLM2-96RW4B 112137-0001	Contact Us	DLM2-96R w/.125 112137-0002	DL2-96R 086-0031-000	DLM2-96R 127050-0216
156	DL1-156RW4B 110536-1006	DL1-156RW4 110536-1003	DL1-156RW4B 112135-0001	DL1-156R w/.125 110536-1011	DLM1-156R w/.125 112135-0002	DL1-156R 086-0030-000	DLM1-156R 127050-0208
260	DL5-260RW4B 111987-0001	Contact Us	DLM5-260RW4B 112087-0001	Contact Us	DLM5-260R w/.125 112087-0003	DL5-260R 086-4501-000	DLM5-260R 127050-0110
360	-	Contact Us	DLM6-360RW4B 111996-0000	Contact Us	DLM6-360R w/.125 111996-0005	-	DLM6-360R 127050-0045
624	DL4-624RW4B 110960-0045	DL4-624RW4 110960-0022	-	Contact Us	-	DL4-624R 110960-0002	-
1248	Contact Us	Contact Us	-	Contact Us	-	DL4-1248R 110960-0003	-
2496	Contact Us	Contact Us	-	Contact Us	-	DL4-2496R 110960-0004	-

ACCESSORIES

CONNECTOR STYLE	PLUG ACTUATING HANDLES	PLUG PROTECTIVE COVERS	RECEPTACLE PROTECTIVE COVERS	METAL BACKSHELL	MAX. CABLE SIZE
DL/DLM3-60	204-0016-000	039-0246-000 025-0850-000†	039-0247-000	249-4518-000	.750 (19.05)
DL/DLM2-96		039-0244-000 025-0851-000†	039-0245-000	249-4517-000	
DL/DLM1-156		039-0242-000 025-0852-000†	039-0243-000	249-4520-000	
DL/DLM5-260	204-4501-000	-	-	249-4501-000	.875 (22.23)
DL/DLM6-360	204-4500-000	-	-	249-4515-000	1.102 (28.00)
DL4-624	-	039-0239-000	039-0240-000	-	-
DL4-1248	-	039-0245-000	039-0236-000	-	-

† Low cost plastic
All dimensions in inches (millimeters in parentheses)

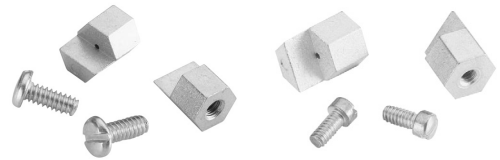

PLASTIC BACKSHELL	CABLE CLAMP FOR SECOND ENTRY IN PLASTIC BACKSHELL	MAX CABLE SIZE	POLARIZING POSTS	
			CORNER (NOTE: POST REPLACES NUT)	CENTER
249-2060-000 249-2237-000 249-2237-001 249-2060-001▲	218-0180-000 218-0181-000 218-0200-000 218-0181-000	.560 14.20mm .625 15.90mm .875 22.23mm .625 15.90mm 45°	320-0021-006 DL 320-4505-000 DLM	-
249-1985-000 249-2238-000 249-2238-001 249-1985-001▲	218-0180-000 218-0181-000 218-0200-000 218-0181-000	.560 14.20mm .625 15.90mm .875 22.23mm .625 15.90mm 45°		320-0021-005
249-1950-000	218-0179-000	.875 (22.23mm)	320-0021-006 DL	-
-	-	-	320-4502-000	-
-	-	-	320-0021-006	-
-	-	-	-	-
-	-	-	-	-

▲ 45 Degree Cable Entry
All dimensions in inches (millimeters in parentheses)

PRINTED CIRCUIT CONTACTS

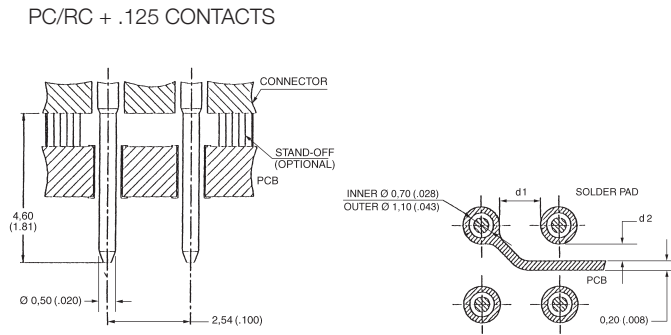
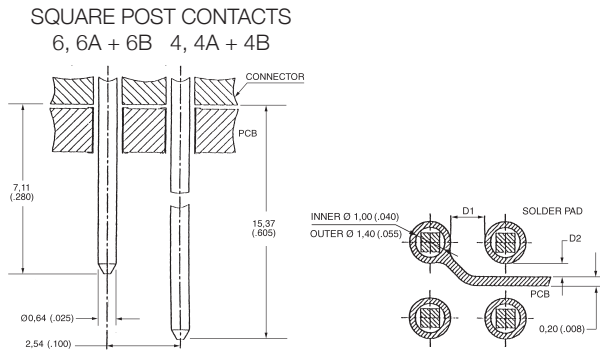

DIMENSIONS	
D1	1.14 (.045)
D2	0.47 (.018)
d1	1.44 (.057)
d2	0.82 (.024)

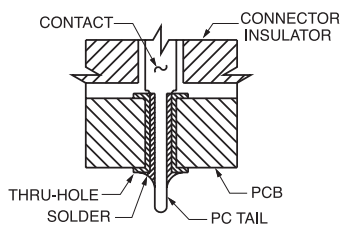

All dimensions in inches (millimeters in parentheses)

For the PC/RC Versions: The contact tail design has been modified from a 0.64 in (.025 mm) square pin to a 0.05 in (.020 mm) diameter round pin. The change enables a decrease in the diameter of the through holes as well as the solder mounds on PCB's (d1 and d2 can be wider than D1 and D2). This can reduce the crosstalk in RF circuits and enhance the dielectric withstanding voltage in high voltage circuits.

The soldering of contacts into through (THRU) holes on a PC Board has become standard for medical equipment and test equipment for semi-conductors. As a result of the narrow spacing between the solder pad and circuit pattern, crosstalk between signals increases. A solution to this problem is to make the diameter of the contacts and solder lands smaller to provide more space between the lands and the patterns. However, a smaller diameter contact results in higher impedance.

ITT Cannon designed a solution with a smaller diameter contact tail. This design application allows the use of a smaller through-hole diameter.

BUMP & FLAT CONTACTS

WIRE SIZE AWG	PLATING (MATING AREA BALANCE OF CONTACT)	BUMP CONTACTS FOR PLUGS/RECEPTACLES		FLAT CONTACTS FOR PLUGS/RECEPTACLES		WIRE STRIP LENGTH	MAXIMUM INSULATION DIAMETER	HAND CRIMP TOOL	EXTRACTION TOOL
		LOOSE	10,000 PIECE REEL*	LOOSE	10,000 PIECE REEL*				
28-32	50µ" Gold-Gold Flash	030-2416-003	110238-0482	030-2494-001	110238-0486	.130 (3.30)	.053 (1.35)	112108-0002	274-7029-007 TIP 333-7159-000
	20µ" Gold-Tin Lead	030-2416-001	110238-0403	-	-				
24-26	50µ" Gold-Gold Flash	030-2410-003	110238-0480	030-2492-001	110238-0484				
	20µ" Gold-Tin Lead	030-2410-001	110238-0401	-	-				
20-22	50µ" Gold-Gold Flash	030-2409-003	110238-0479	030-2491-001	110238-0483	.160 (4.06)	.074 (1.88)	112108-0001	
	20µ" Gold-Tin Lead	030-2409-001	110238-0400	-	-				
18-20	50µ" Gold-Gold Flash	030-2415-003	110238-0481	030-2493-001	110238-0485				
	20µ" Gold-Tin Lead	030-2415-001	110238-0402	-	-				

For applications that will have over 100 milliamps bump, contact may be used in both plugs and receptacle housings.

Flat contacts provide excellent wiping action, can always be used in receptacle housings and are required for applications using 100 milliamps or less.

*Contact us for Autocrimp Tool information.

All dimensions in inches (millimeters in parentheses)

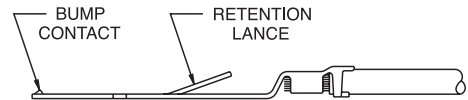

HIGH AMPERAGE BUSS CONTACTS

BUSS NUMBER OF PAIRS	PLATING MATING AREA-BALANCE	PART NUMBER	MAXIMUM CURRENT	EXTRACTION TOOL
1	20µ" Gold-Gold Flash	030-7380-001	10 Amp	274-7029-003
2		030-7380-002	20 Amp	274-7029-004
3		030-7380-003	30 Amp	
4		030-7380-004	40 Amp	274-7029-005
5		030-7380-005	50 Amp	274-7029-006
6		030-7380-006	60 Amp	

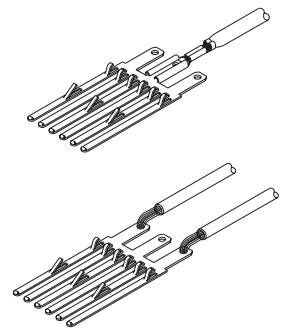

Note: DL buss contacts will accommodate 18-30 AWG wires for soldering or 1/8" crimp lugs.

PLUGS

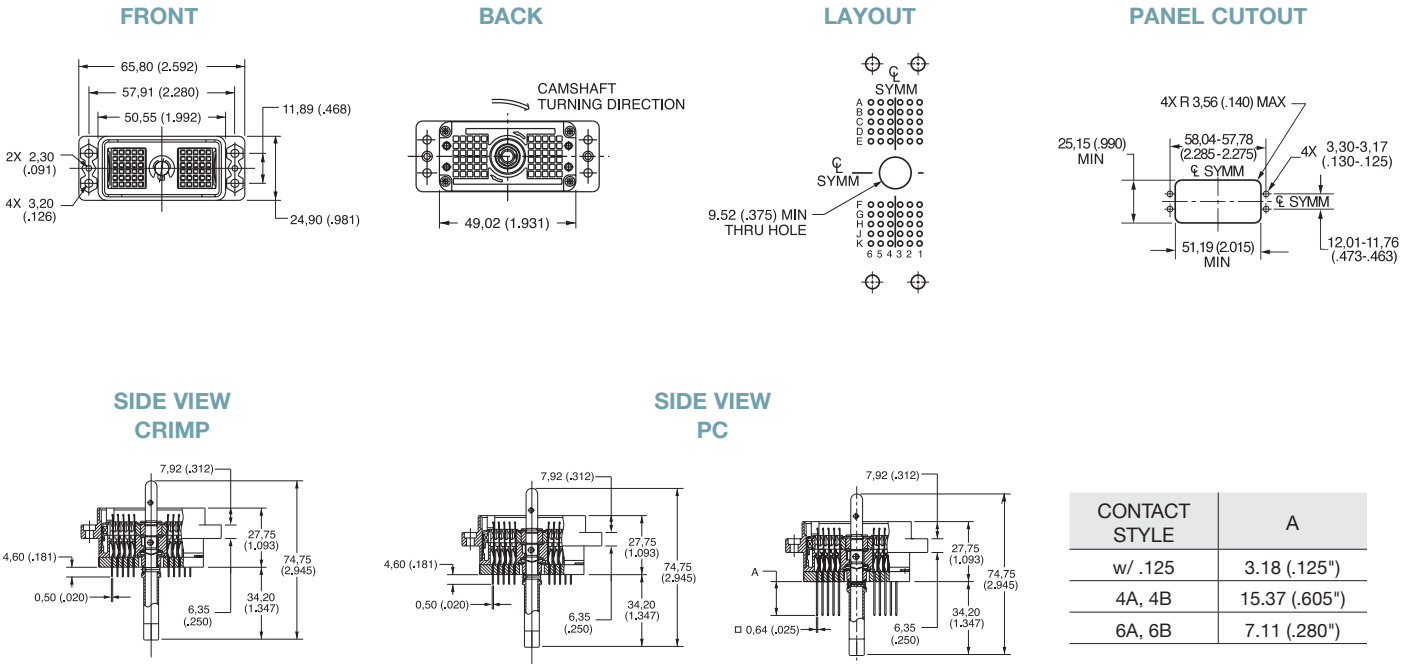

All dimensions in millimeters (inches in parentheses)

RECEPTACLES

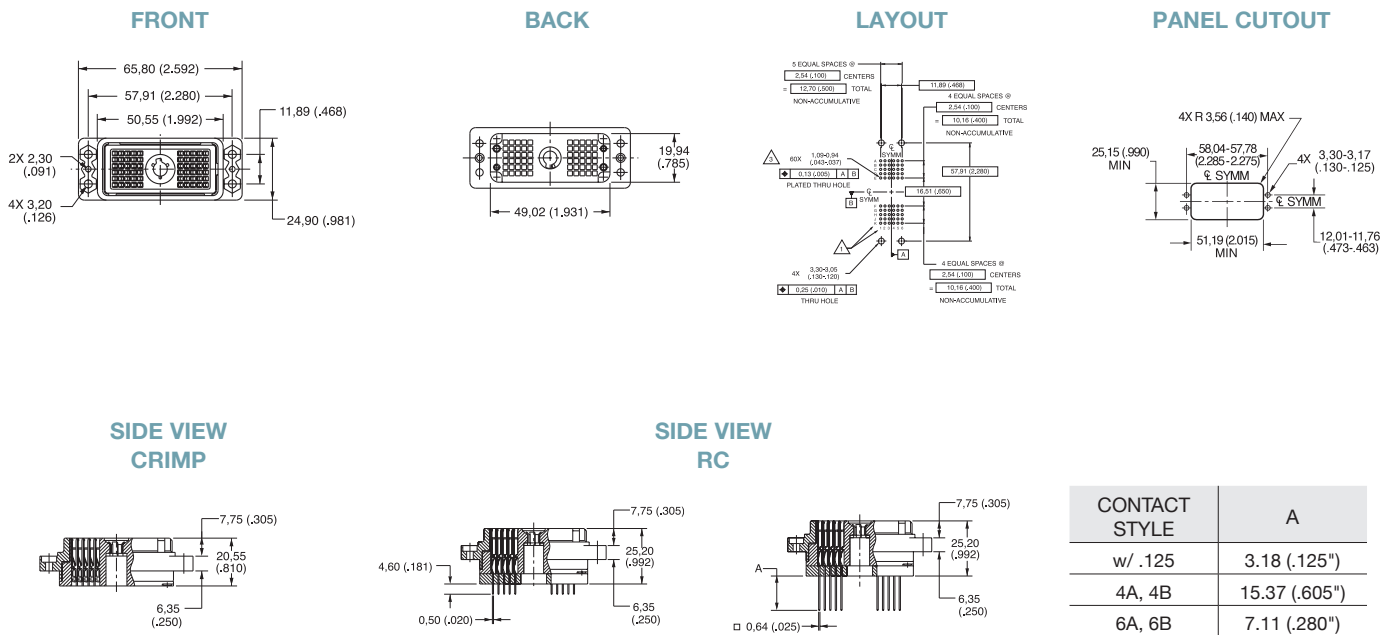

All dimensions in millimeters (inches in parentheses)

PLUGS

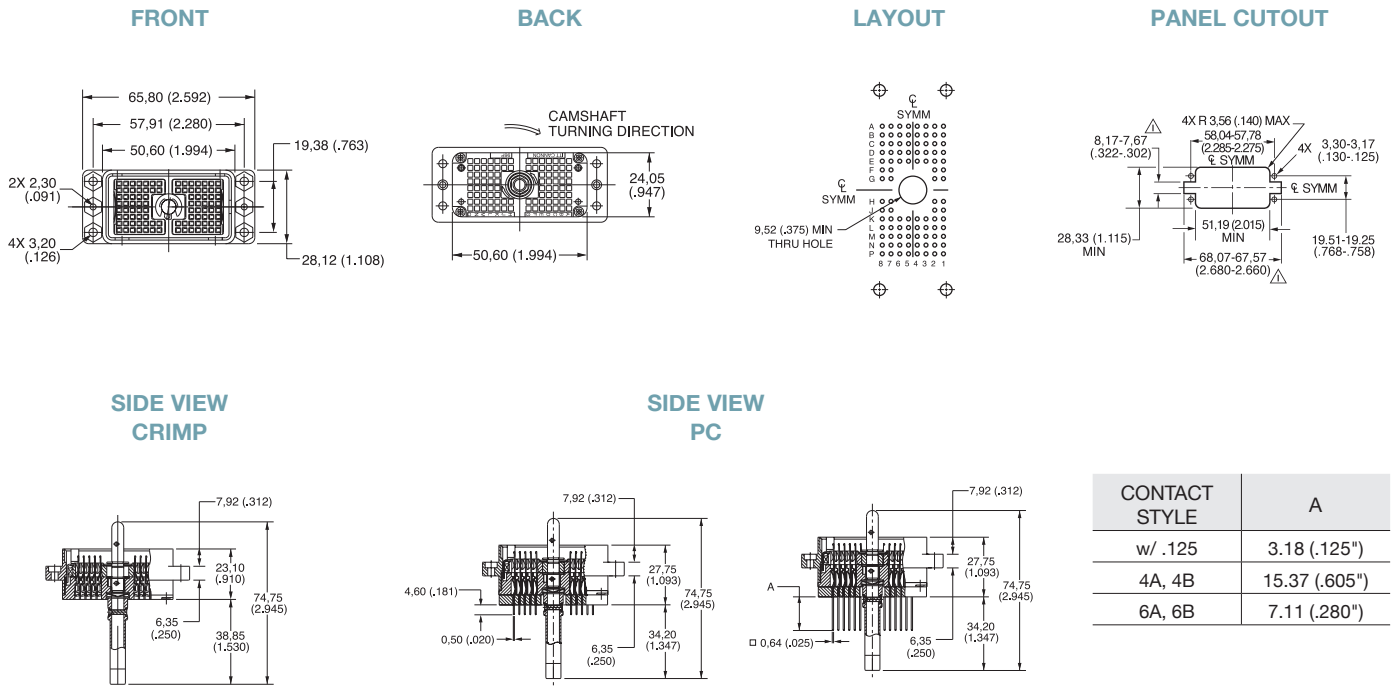

CONTACT STYLE	A
w/ .125	3.18 (.125")
4A, 4B	15.37 (.605")
6A, 6B	7.11 (.280")

All dimensions in millimeters (inches in parentheses)

RECEPTACLES

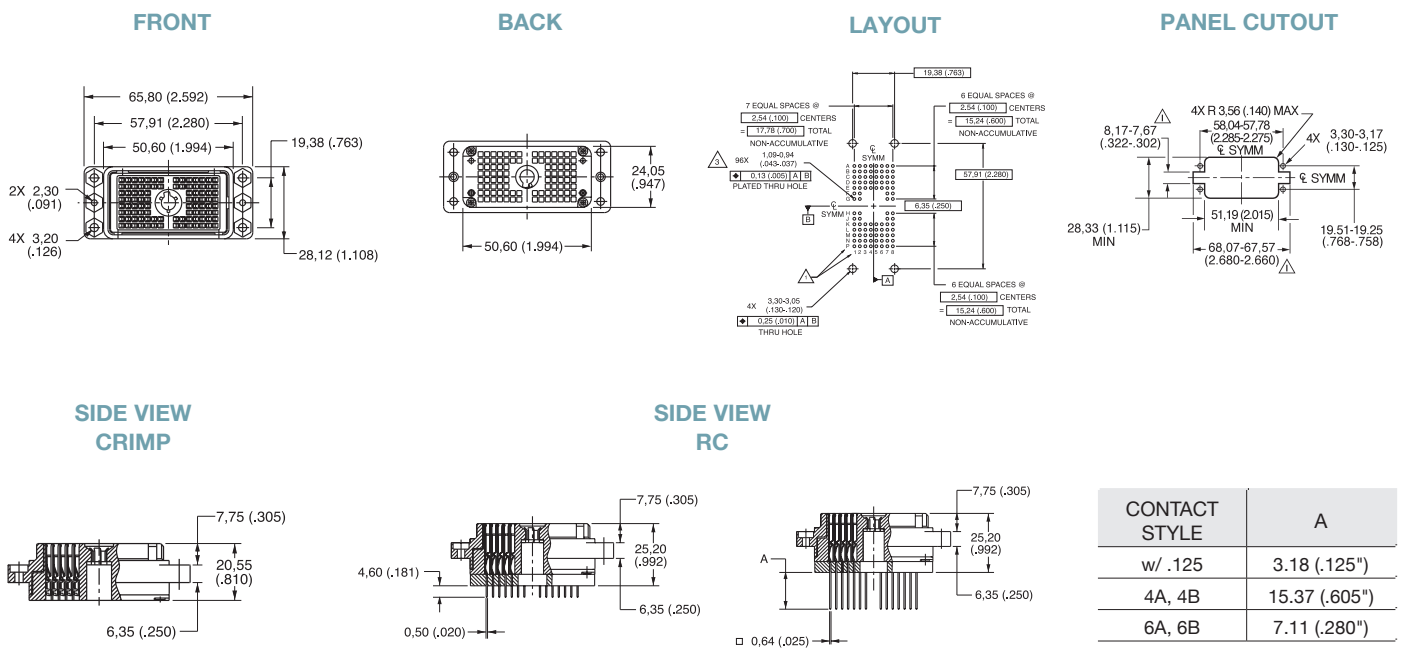

CONTACT STYLE	A
w/ .125	3.18 (.125")
4A, 4B	15.37 (.605")
6A, 6B	7.11 (.280")

All dimensions in millimeters (inches in parentheses)

PLUGS

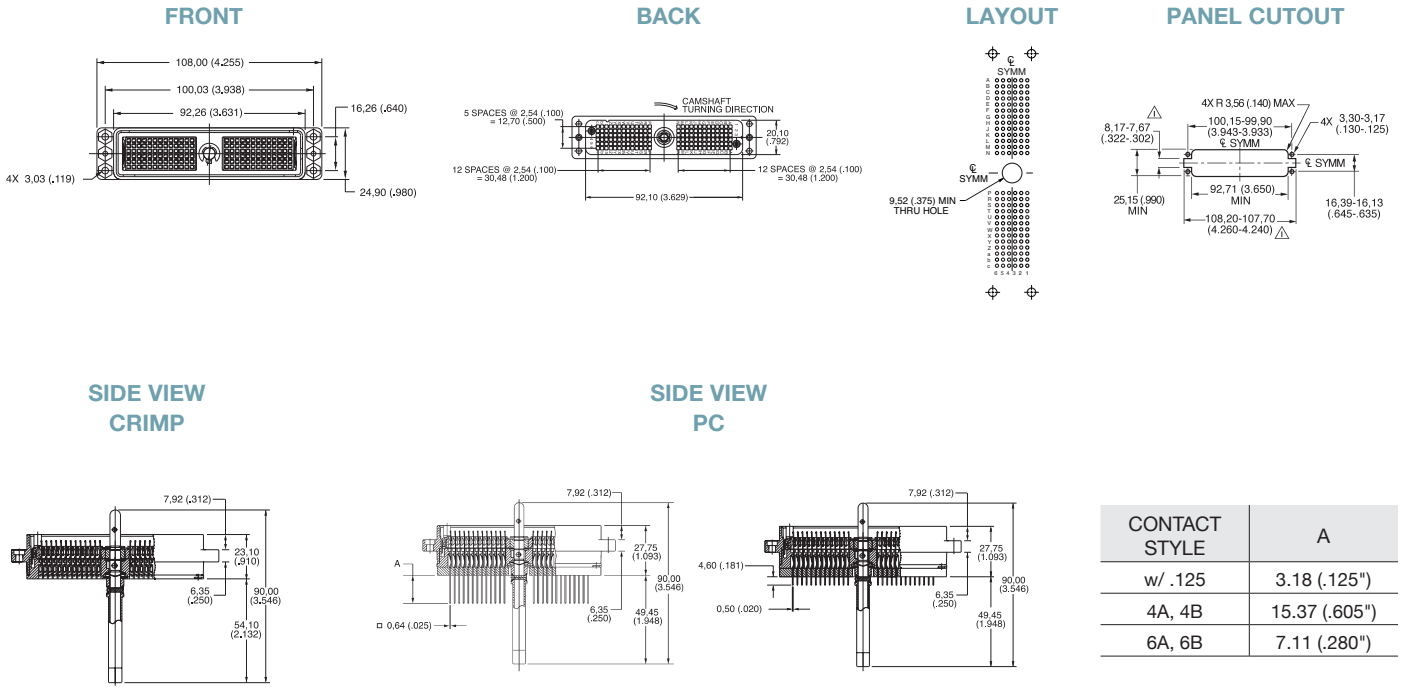

All dimensions in millimeters (inches in parentheses)

RECEPTACLES

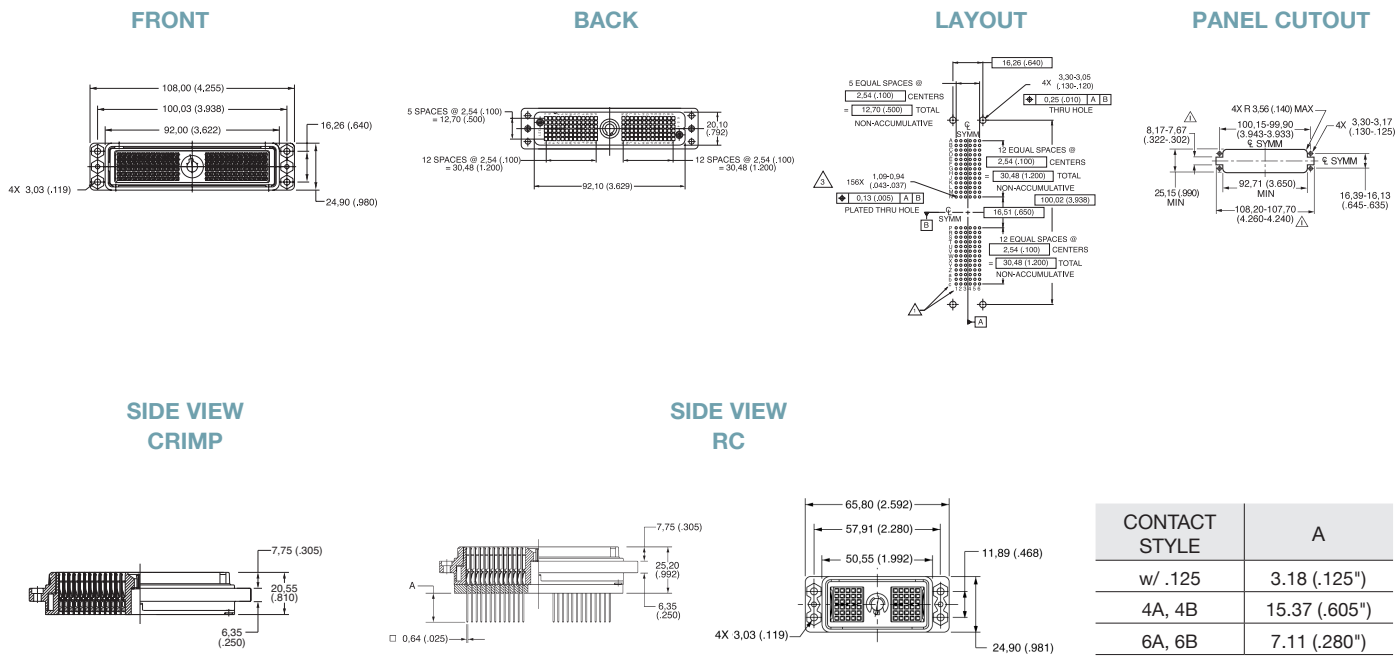

All dimensions in millimeters (inches in parentheses)

PLUGS

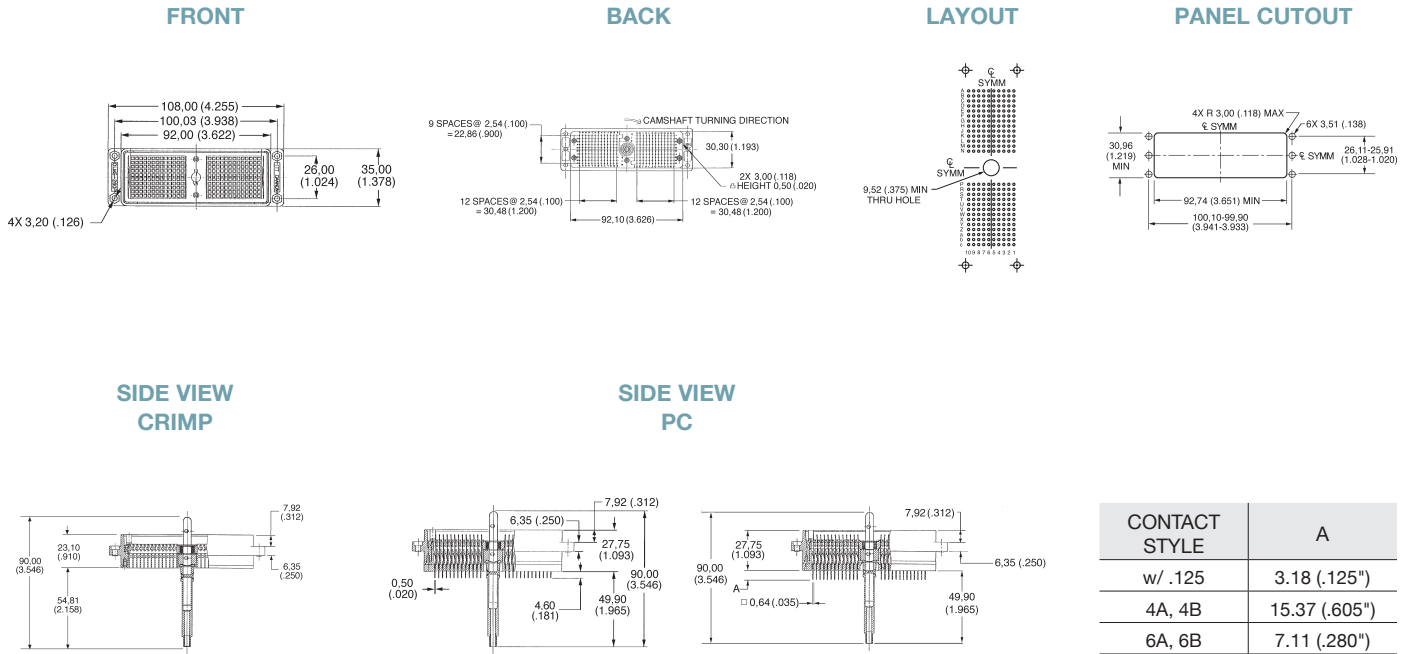

All dimensions in millimeters (inches in parentheses)

RECEPTACLES

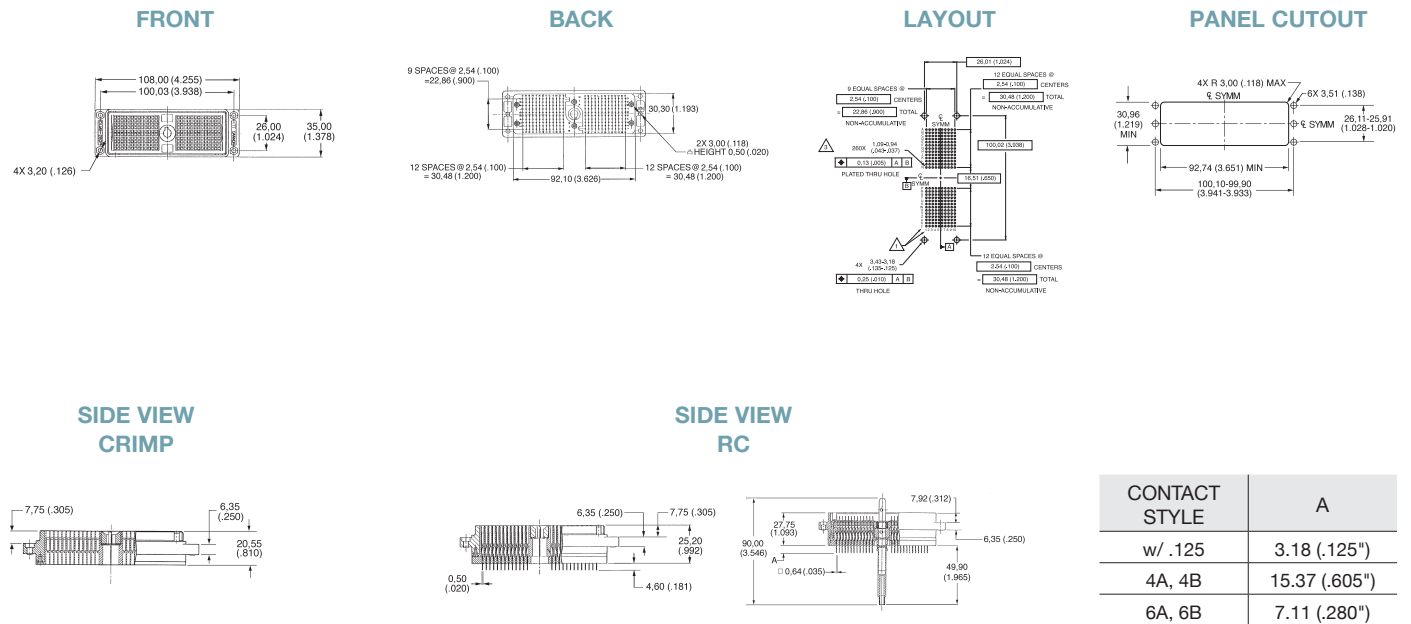

All dimensions in millimeters (inches in parentheses)

PLUGS

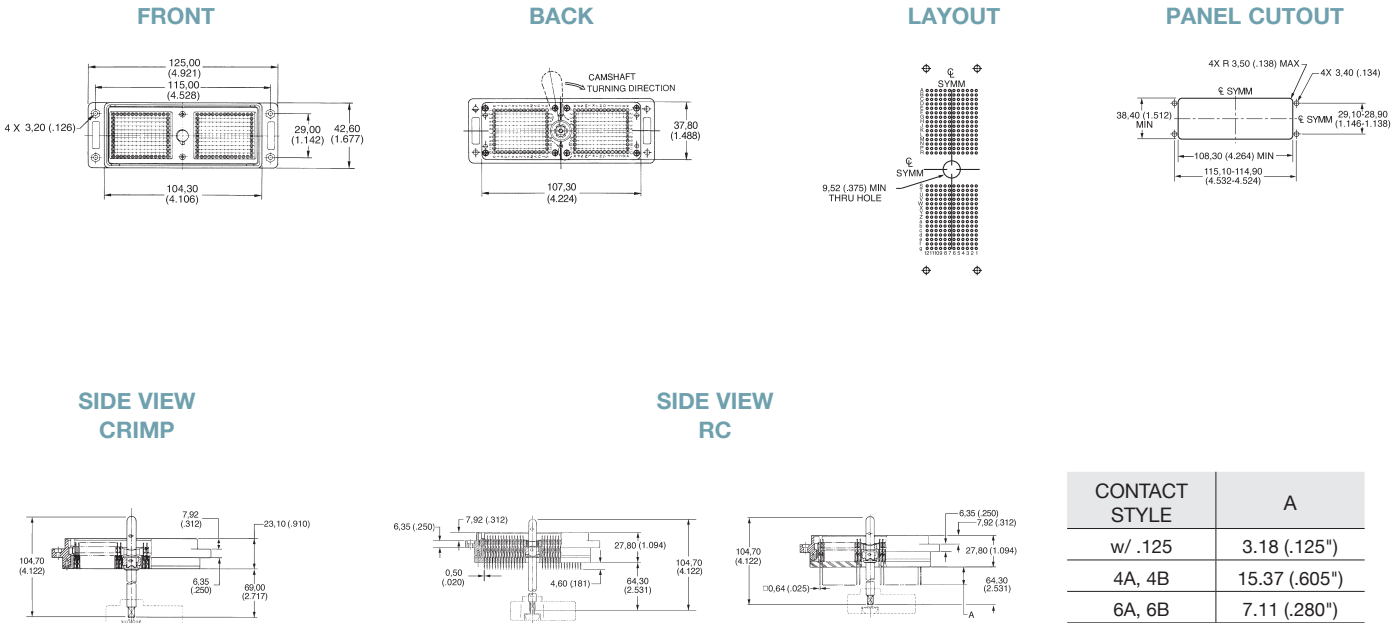

All dimensions in millimeters (inches in parentheses)

RECEPTACLES

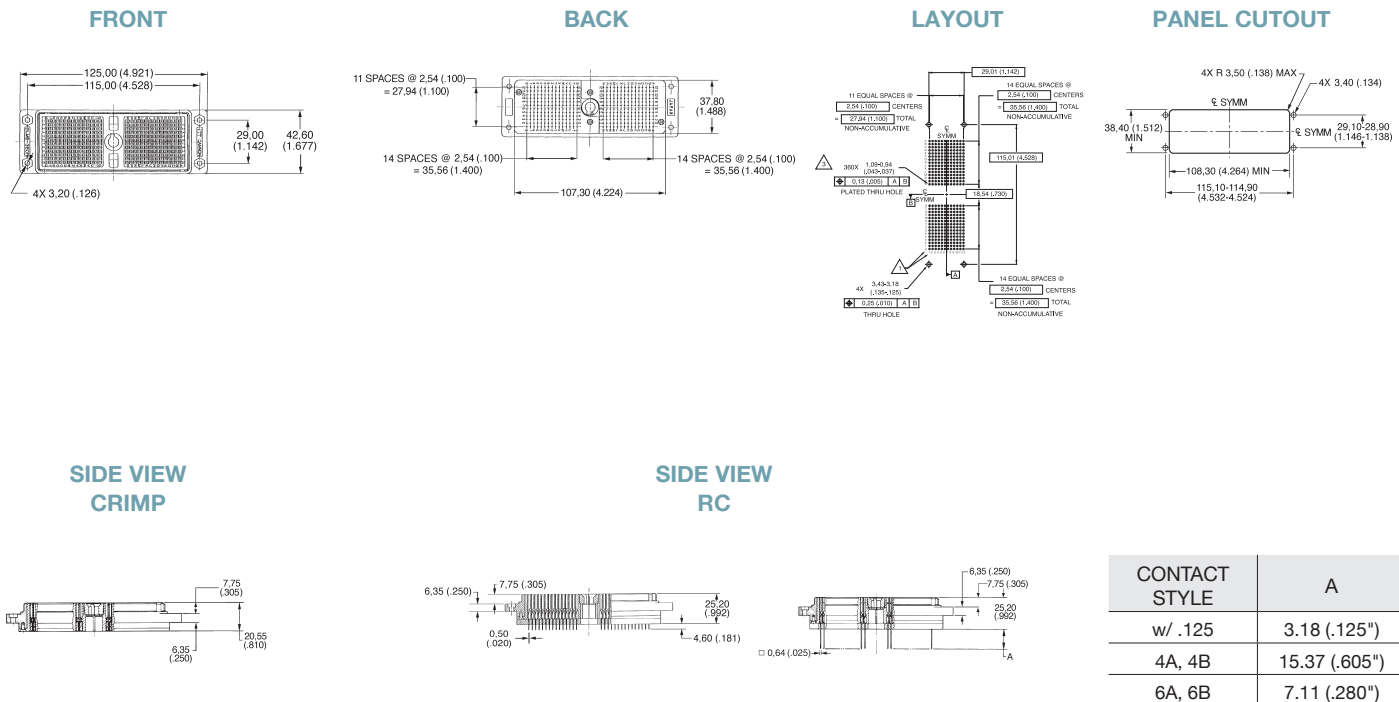

All dimensions in millimeters (inches in parentheses)

PLUGS

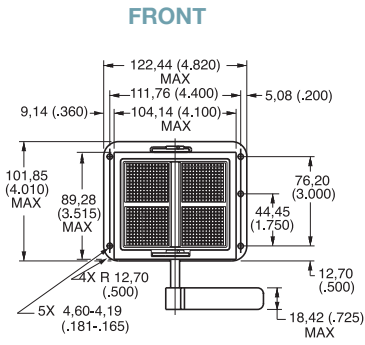

SIDE VIEWS

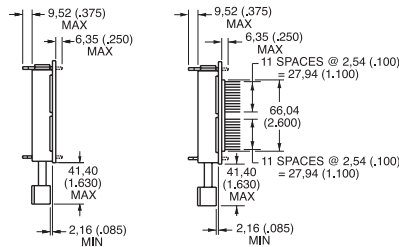

SIDE VIEWS CRIMP

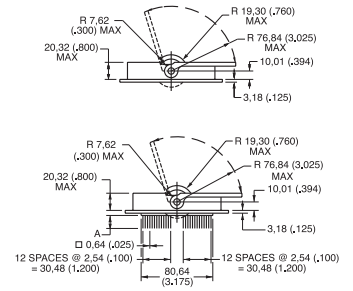

PANEL CUT OUT

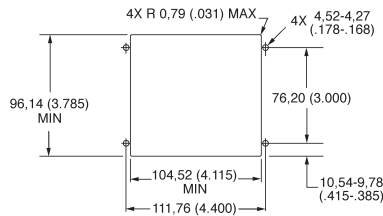

CONTACT STYLE	A
w/ .125	3.18 (.125")
4A, 4B	15.37 (.605")
6A, 6B	7.11 (.280")

All dimensions in millimeters (inches in parentheses)

PLUGS

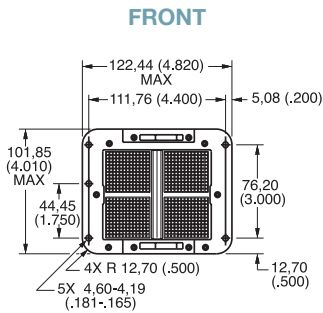

SIDE VIEWS

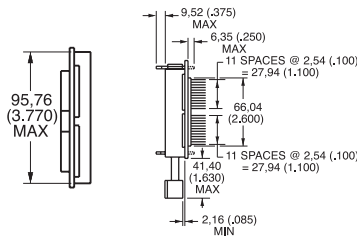

SIDE VIEWS CRIMP

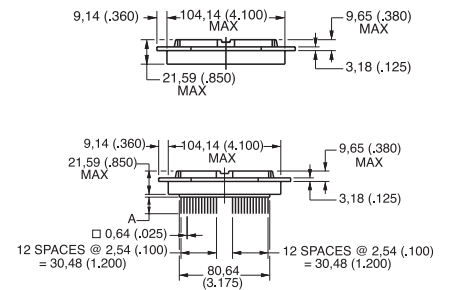

PANEL CUT OUT

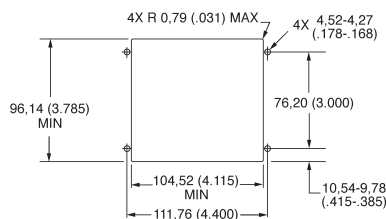

CONTACT STYLE	A
w/ .125	3.18 (.125")
4A, 4B	15.37 (.605")
6A, 6B	7.11 (.280")

All dimensions in millimeters (inches in parentheses)

CONNECTOR STYLE	PLASTIC	METAL
DL/DLM3-60		
DL/DLM2-96		
DL/DLM1-156		
DL/DLM5-260	-	
DL/DLM6-360	-	

All dimensions in millimeters (inches in parentheses)

ASSEMBLY INSTRUCTIONS FOR CRIMP CONTACTS

Contact Insertion: All crimp contacts are inserted by hand. No tooling is required for the plug or receptacle.

Caution: Do not force contacts into contact cavities. If contact encounters excessive resistance during installation, remove and re-insert using a slight up and down motion. This will assure positive cavity alignment. Do not install contact if plug is in the closed or actuated position.

Plug:

Step 1: Prior to inserting contacts, turn the shaft counter-clockwise to its maximum open position.

Step 2: With the retention lance positioned away from the shaft, insert contacts from the rear of the plug.

Receptacle:

Step 1: With the retention lance positioned toward the shaft hole, insert contacts from the rear of the receptacle.

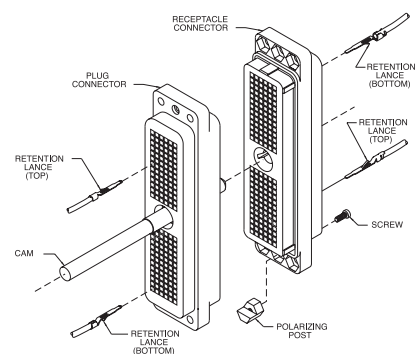

CONTACT REMOVAL FOR CRIMP CONTACTS

Tool: CET-DL10: Release retention lance by inserting tip of extraction tool into cavity until it bottoms on insulator shoulder. Gently pull wire in direction of arrow to remove contact from insulator. See illustration.

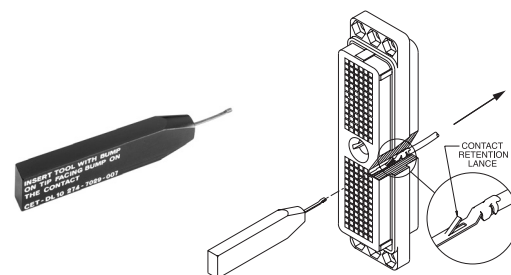

ASSEMBLY INSTRUCTIONS FOR BUSS CONTACTS

Contact Insertion: All buss contacts are inserted by hand. No tooling is required for the plug or receptacle.

Caution: Do not force contacts into contact cavities. If contact encounters excessive resistance during installation, remove and re-insert using a slight up and down motion. This will assure positive cavity alignment. Do not install contact if plug is in the closed or actuated position.

Plug:

Step 1: Prior to inserting contacts, turn the shaft counter-clockwise to its maximum open position.

Step 2: With the retention lance positioned away from the shaft, insert contacts from the rear of the plug.

Receptacle:

Step 1: With the retention lance positioned toward the shaft hole, insert contacts from the rear of the receptacle.

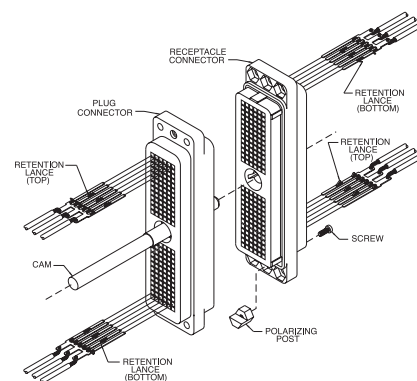

CONTACT REMOVAL FOR BUSS CONTACTS

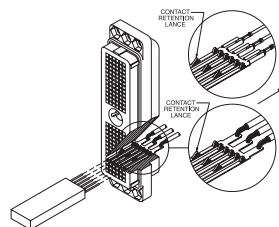

Tool: CET-DL3/4/5/6:

Release retention lance by inserting tip of extraction tool into cavity until it bottoms on insulator shoulder. Gently remove buss contact in direction of arrow to remove contact from insulator. See illustration.