

Specification

Part Number:	MCT039A12W480128LML		
Version:	26/02/2016		
Date:	1		
VERSION	DATE	REVISED PAGE NO.	Note
0 A	2015/09/18 2016/01/21		First issue Modify Static electricity test



Display Size	3.9"
Resolution	480 x 128
VGA Size	N/A
Orientation	Landscape
Appearance	RGB
Logic Voltage	3.3V
Interface	Parallel RGB
Brightness	500 cd/m ²
Touchscreen	N/A
Module Size W x H x D	105.50 x 40.64 x 2.95 mm
Operating Temperature	-20°C ~ +70°C
Pin Out	40 - Way



Contents

1.Module Classification Information

2.Summary

3.General Specification

4.Interface

5.Contour Drawing

6.Block Diagram

7.Absolute Maximum Ratings

8.Electrical Characteristics

9.Interface Timing Characteristics

10.Optical Characteristics

11.Reliability

12.Display start address setting

13.Other

MIDAS

Midas Active Matrix Display Part Number System

MC T 057 A 6 * W 320240 L M L * *
1 2 3 4 5 6 7 8 9 10 11 12 13

- 1 = **MC:** Midas Components
- 2 = **T:** TFTA: Active Matrix OLED
- 3 = **Size**
- 4 = **Series**
- 5 = **Viewing Angle:** 6: 6 O'clock 12: 12 O'clock O: All Round Viewing Angle
- 6 = **Blank:** No Touch T: Resistive Touchscreen C: Capacitive Touchscreen
- 7 = **Operating Temp Range:** S: 0+50Deg C B: -20+60Deg C
W: -20+70Deg C E: -30+85Deg C
X: -30+80Deg C
- 8 = **No of Pixels**
- 9 = **Orientation:** P: Portrait L: Landscape
- 10 = **Mode:** R: Reflective M: Transmissive T: Transflective
S: Sunlight Readable (Transmissive) W: White on Black (Monochrome)
- 11 = **Backlight:** Blank: None L: LED C: CCFL
- 12 = **Blank:** No Module/board C: Controller board module (E-Tech)
- 13 = **Blank:** None OB: Optically Bonded IPS: In-plane switching

2.Summary

This technical specification applies to 3.9' color TFT-LCD panel. The 3.9' color TFT-LCD panel is designed for camcorder, digital camera application and other electronic products which require high quality flat panel displays. This module follows RoHS.

MIDAS

3. General Specifications

- Size: 3.9 inch
- Dot Matrix: 480 x RGBx128(TFT) dots
- Module dimension: 105.5(W) x 40.64(H) x 2.95(D) mm
- Active area: 95.04 x 25.34 mm
- Dot pitch: 0.066(W)x 0.198(H) mm
- LCD type: TFT, Normally White, Transmissive
- View Direction: 12 o'clock
- Gray Scale Inversion Direction: 6 o'clock
- Backlight Type: LED, Normally White
- With /Without TP: Without TP
- Surface: Anti-Glare

*Color tone slight changed by temperature and driving voltage.

MIDAS

4.Interface

4.1. LCM PIN Definition

No.	Symbol	Description
1	VBL-	Backlight LED Cathode
2	VBL+	Backlight LED Anode.
3	GND	System Ground
4	VDD	Power supply for logic operation
5~12	R0~R7	Data bus
13~20	G0~G7	Data bus
21~28	B0~B7	Data bus
29	GND	System Ground
30	DCLK	Pixel clock signal
31	DISP	Display on/off control
32	HSYNC	Horizontal Sync signal
33	VSYNC	Vrtical Sync signal
34	DE	Data Enable
35	NC	No connection
36	GND	System Ground
37	NC	No connection
38	NC	No connection
39	NC	No connection
40	NC	No connection

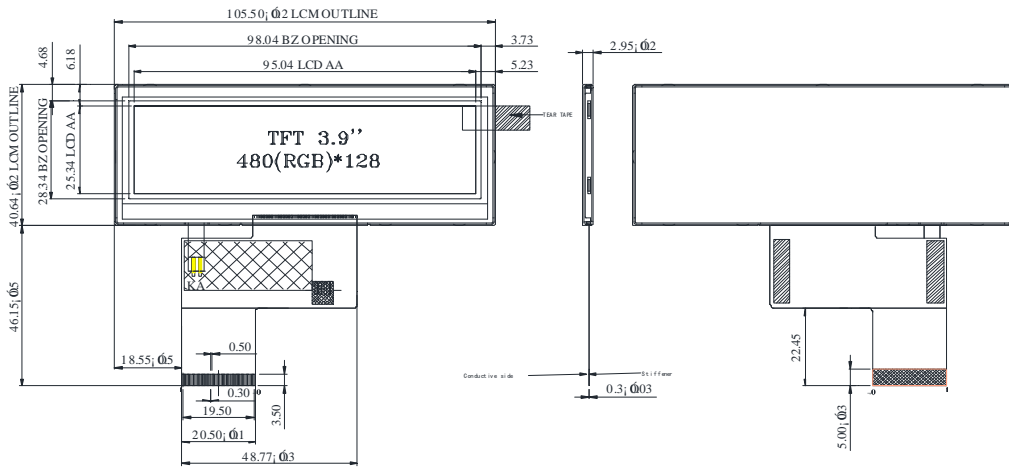

PIN NO.	S: MBOL	PIN NO.	SYMBOL
1	VBL-	21	B0
2	VBL+	22	B1
3	GND	23	B2
4	VDD	24	B3
5	R0	25	B4
6	R1	26	B5
7	R2	27	B6
8	R3	28	B7
9	R4	29	GND
10	R5	30	DCLK
11	R6	31	DISP
12	R7	32	HSYNC
13	G0	33	VSYNC
14	G1	34	DE
15	G2	35	NC
16	G3	36	GND
17	G4	37	NC
18	G5	38	NC
19	G6	39	NC
20	G7	40	NC

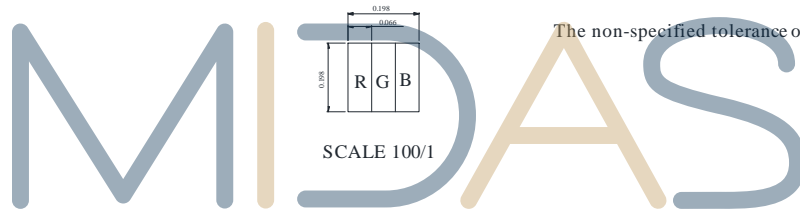

The non-specified tolerance of dimension is $\pm 0.3\text{mm}$.

6. Block Diagram

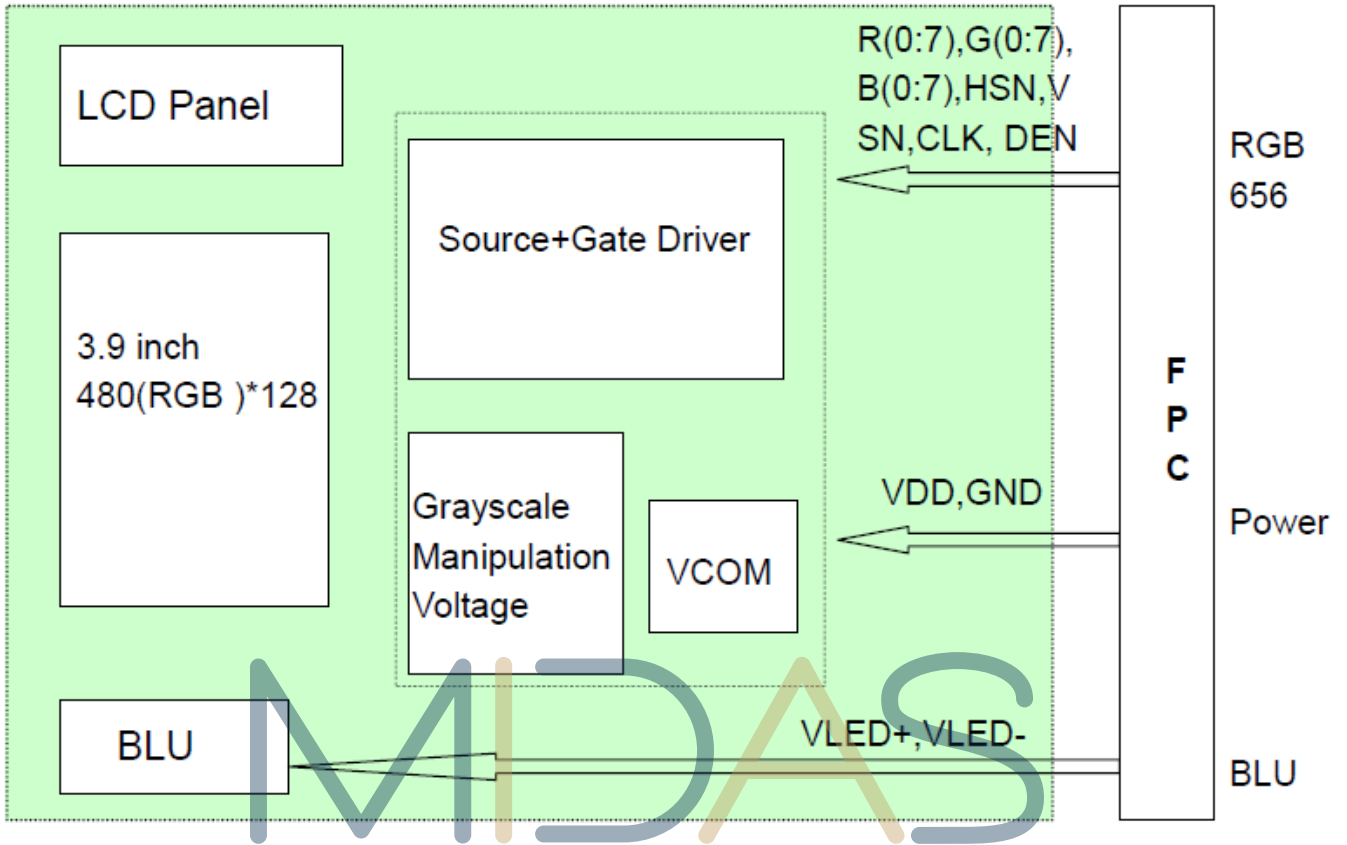

7. Absolute Maximum Ratings

Item	Symbol	Min	Typ	Max	Unit
Operating Temperature	TOP	-20	—	+70	□
Storage Temperature	TST	-30	—	+80	□

Note: Device is subject to be damaged permanently if stresses beyond those absolute maximum ratings listed above

- Temp. $\leq 60^{\circ}\text{C}$, 90% RH MAX. Temp. $> 60^{\circ}\text{C}$, Absolute humidity shall be less than 90% RH at 60°C

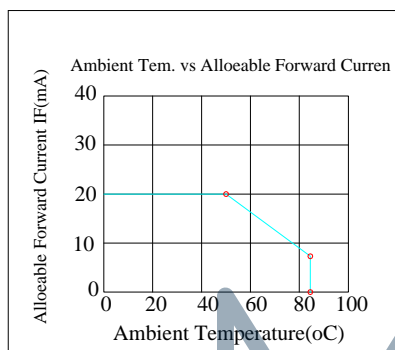

MIDAS

8. Electrical Characteristics

8.1. Operating conditions:

Item	Symbol	MIN	TYP	MAX	Unit	Remark
Supply Voltage	V_{DD}	3.0	3.3	3.6	V	
Input Signal Voltage	Low Level	V_{IL}	GND	-	$0.3 \times V_{DD}$	V
	High Level	V_{IH}	$0.7 \times V_{DD}$	-	VDD	V

8.2. LED driving conditions

Item	Symbol	MIN	TYP	MAX	Unit	Remark
Forward Current	I_F	36	40	50	mA	
Forward Voltage	V_F	15	16	17.5	V	
Backlight life time		-	25000	-	hr	

Note 1 : There are 1 Groups LED

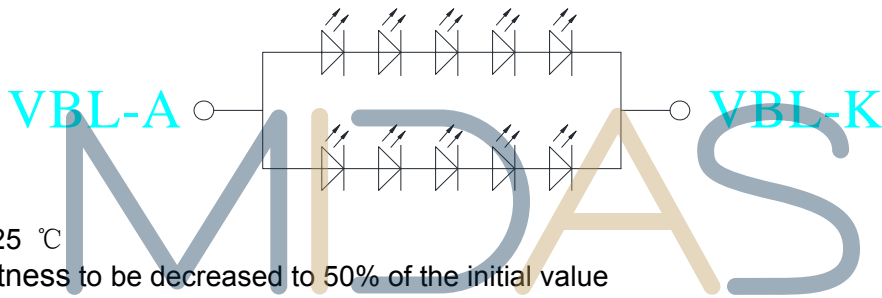

Note 2 : $T_a = 25 \text{ }^\circ\text{C}$

Note 3 : Brightness to be decreased to 50% of the initial value

Note 4 : The single LED lamp case

9. Interface Timing

9.1. Clock and Data input Waveforms

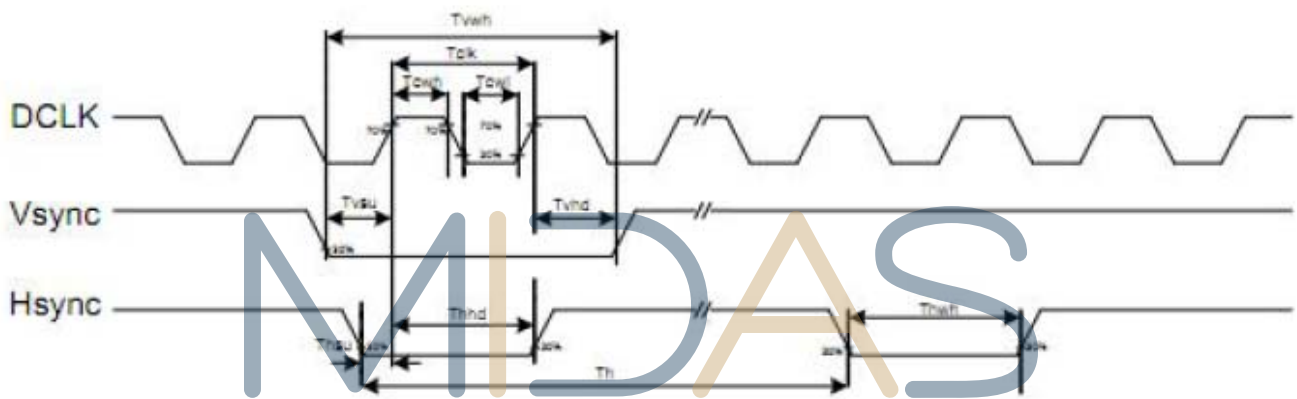
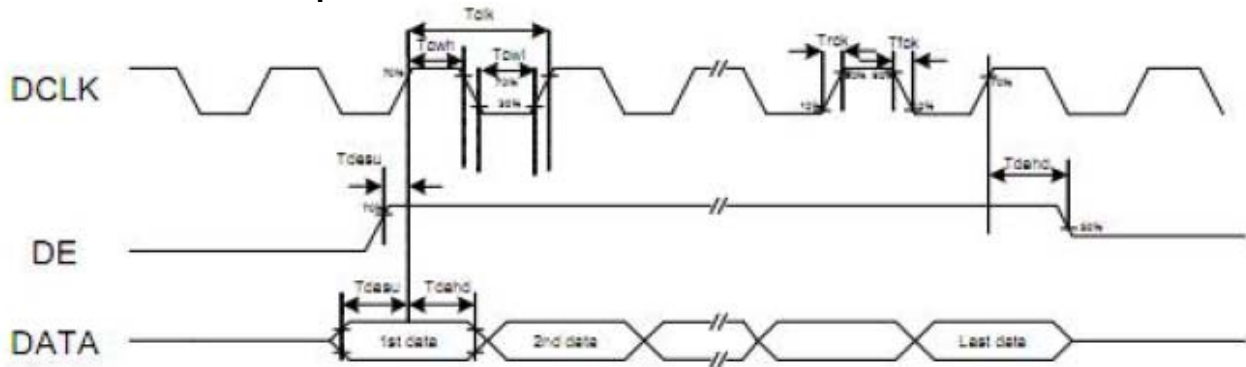

Data input Format

Vertical input timing

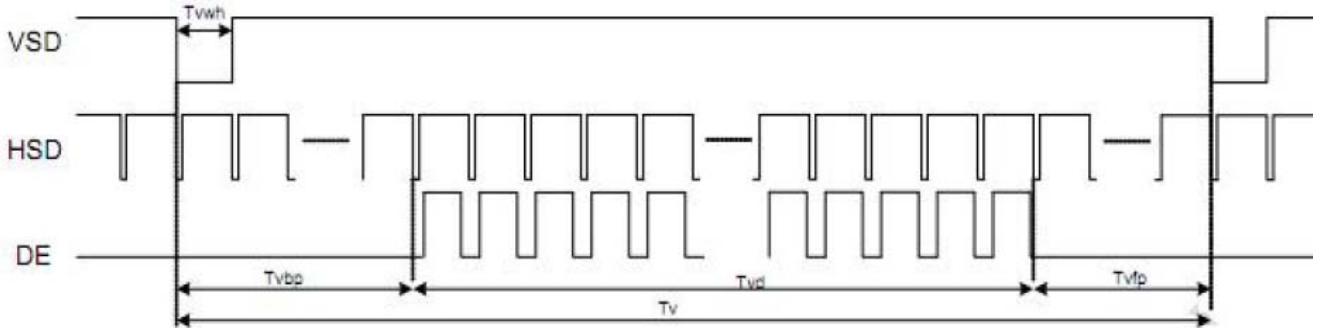

Serial 8-bit RGB Mode Data format

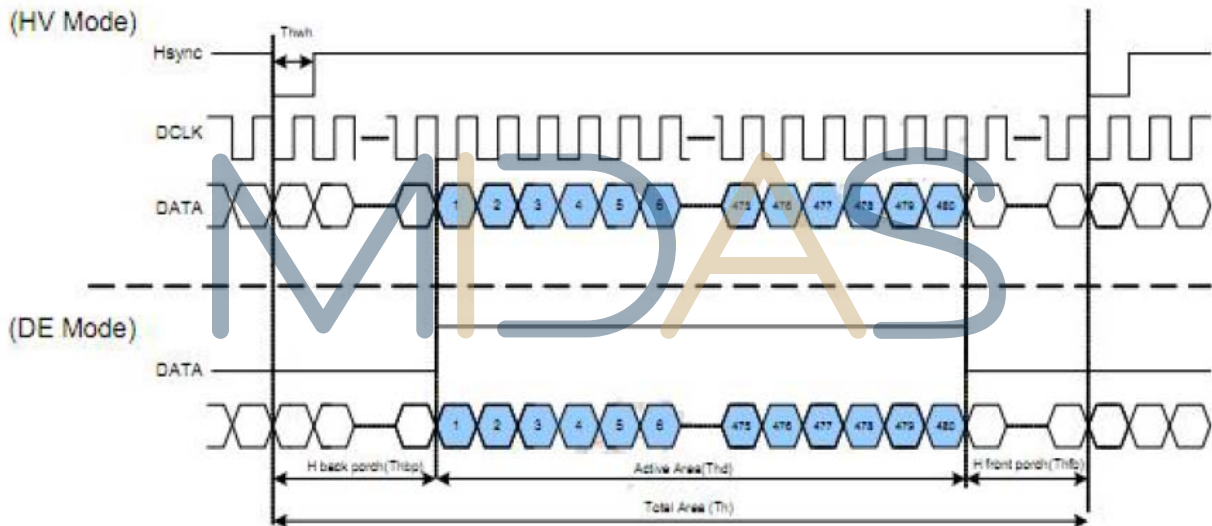

Parameter	Symbol	Min.	Typ.	Max.	Unit	Condition
OCLK frequency	Fclk	24	27	30	MHz	
OCLK cycle time	Tclk	83	110	200	ns	
OCLK pulse duty	Tcwh	40	50	60	%	
Time from HSD to source	Thso		13		CLK	
Time from HSD to gate output	Thgo	.	27	.	DCLK	
Time from HSO 10 gate output	Thgz		3		OCLK	
Time from HSO 10 VCOM	Thvc		12	.	OCLK	

Parallel RGB mode data format

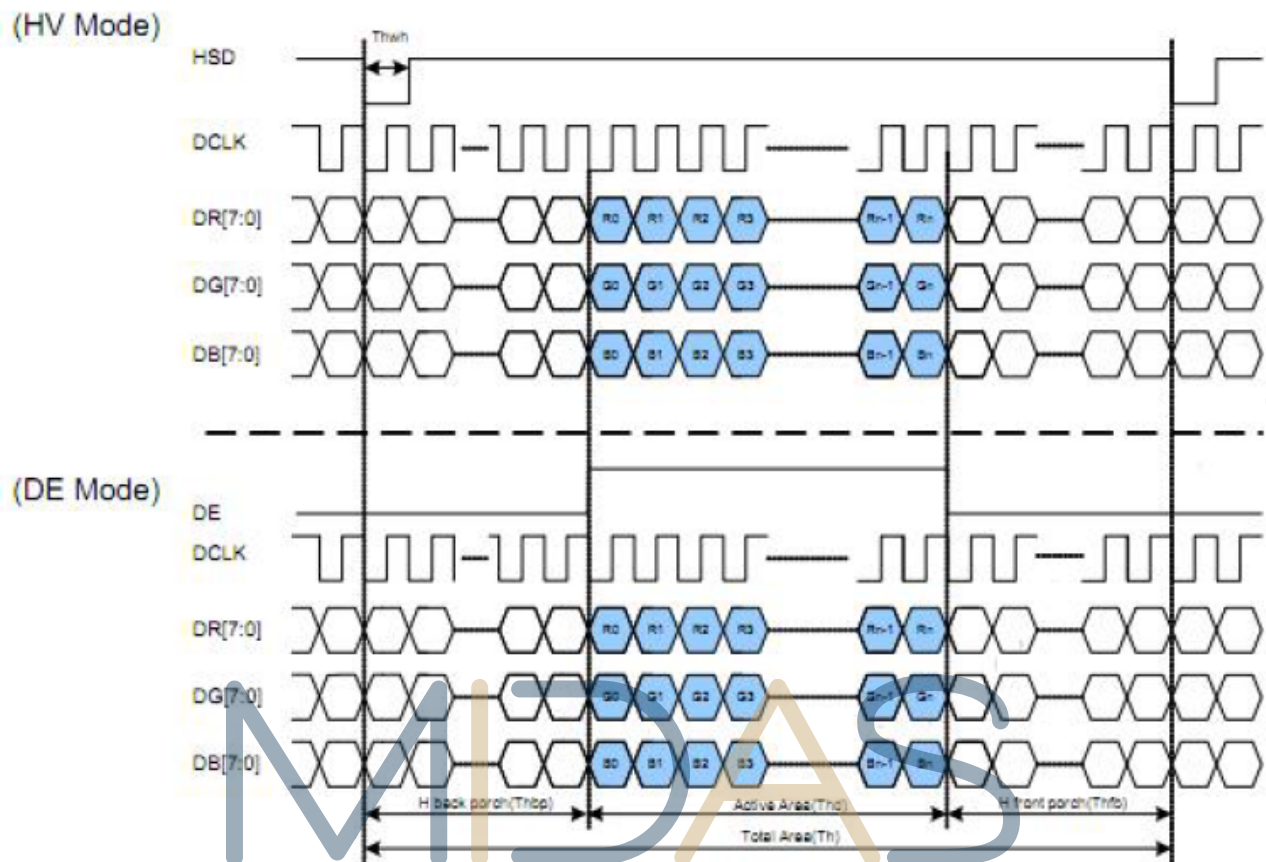

Parallel RGB input timing table

Parameters	Symbol	Valute			Unit
		Min.	Typ.	Max.	
DCLK frequency	fclk	5	9	12	MHz
VSD period time	T_v	277	288	400	H
VSD display area	T_{vd}	272			H
VSD back porch	T_{vb}	3	8	31	H
VSD front porch	T_{vfp}	2	8	97	H
HSD period time	T_h	520	525	800	DCLK
HSD display area	T_{hd}	480			DCLK
HSD back porch	T_{hbp}	36	40	255	DCLK
HSD front porch	T_{hfp}	4	5	65	DCLK

9.2. Output Timing Diagram

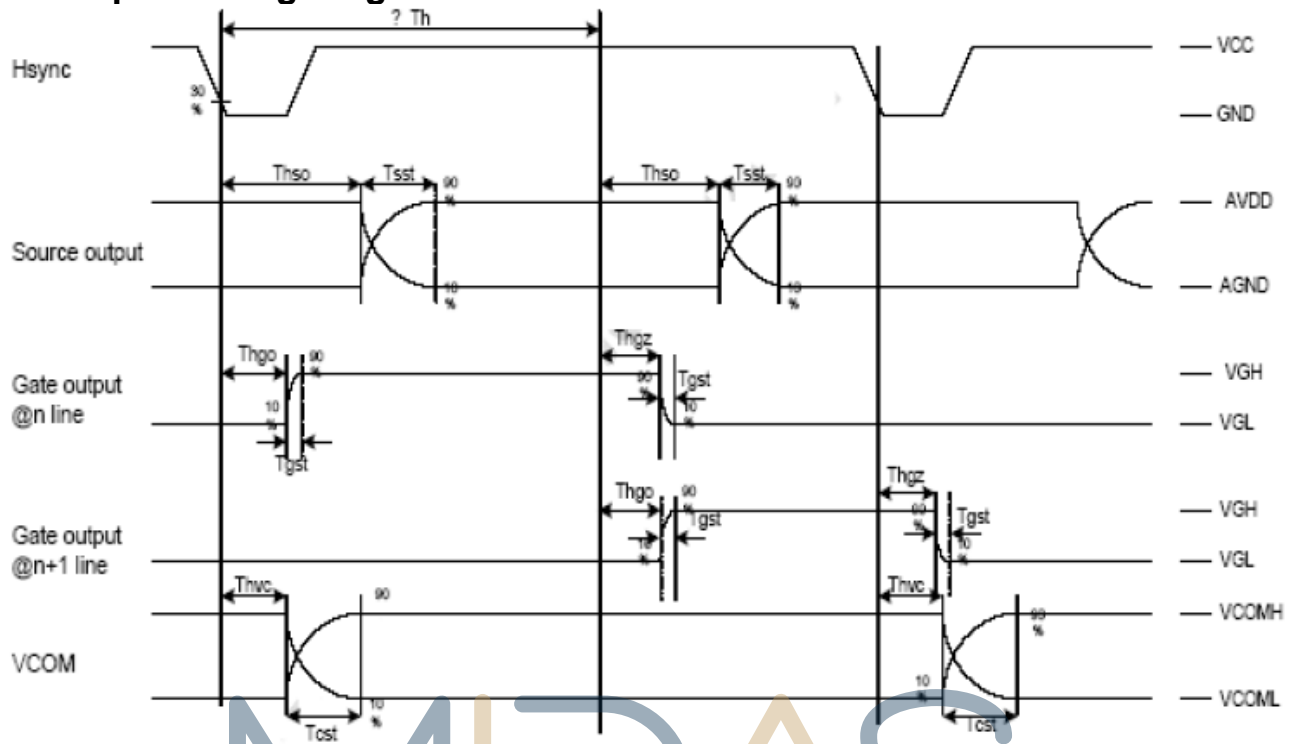

MIDAS

10. Optical Characteristics

Item	Symbol	Condition.	Min	Typ.	Max.	Unit	Remark	
Response time	T_r	$\theta=0^\circ$ 、 $\phi=0^\circ$	-	10	20	ms	Note 3	
	T_f		-	15	30			
Contrast ratio	CR	At optimized viewing angle	400	500	-	-	Note 4	
Color Chromaticity	White	$\theta=0^\circ$ 、 $\phi=0^\circ$	W_x	0.26	0.31	0.36	-	Note 2,5
			W_y	0.28	0.33	0.38	-	
Viewing angle (Gray Scale Inversion Direction)	Hor.	$CR \geq 10$	θ_R	60	70	-	Deg	Note 1
			θ_L	60	70	-		
	Ver.		ϕ_T	40	50	-		
			ϕ_B	60	70	-		
Brightness	-	-	400	500	-	cd/m ²	Center of display	

Ta=25±2°C,

Note 1: Definition of viewing angle range

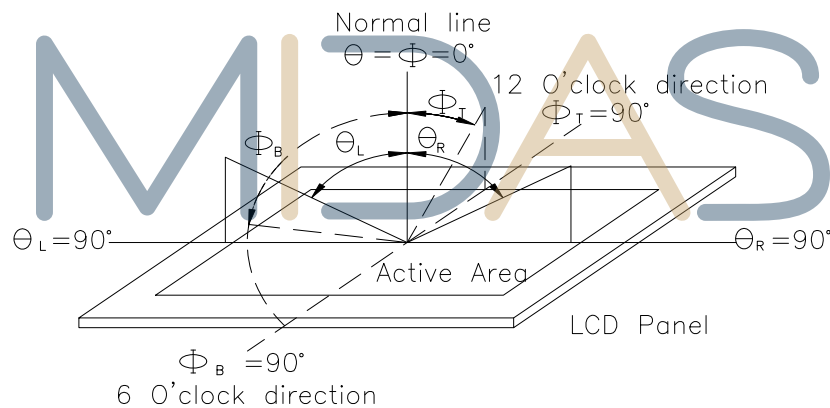

Fig. 10.1. Definition of viewing angle

Note 2: Test equipment setup:

After stabilizing and leaving the panel alone at a driven temperature for 10 minutes, the measurement should be executed. Measurement should be executed in a stable, windless, and dark room. Optical specifications are measured by Topcon BM-7 or BM-5 luminance meter 1.0° field of view at a distance of 50cm and normal direction.

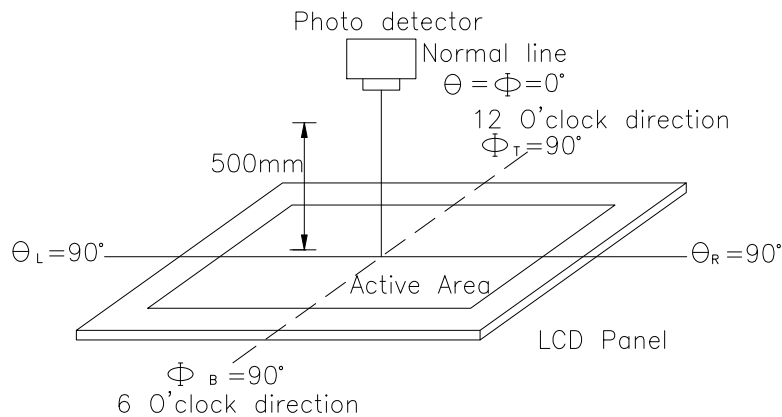
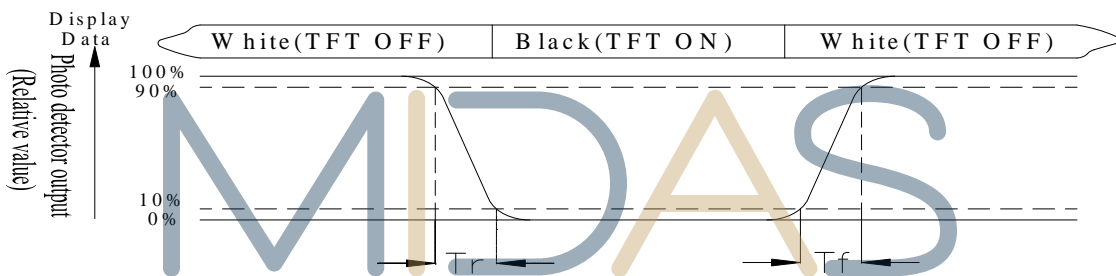

Fig. 10.2. Optical measurement system setup

Note 3: Definition of Response time:

The response time is defined as the LCD optical switching time interval between “White” state and “Black” state. Rise time, T_r , is the time between photo detector output intensity changed from 90% to 10%. And fall time, T_f , is the time between photo detector output intensity changed from 10% to 90%



Note 4: Definition of contrast ratio:

The contrast ratio is defined as the following expression.

$$\text{Contrast ratio (CR)} = \frac{\text{Luminance measured when LCD on the "White" state}}{\text{Luminance measured when LCD on the "Black" state}}$$

Note 5: White $V_i = V_{i50} \pm 1.5V$

Black $V_i = V_{i50} \pm 2.0V$

“±” means that the analog input signal swings in phase with VCOM signal.

“±” means that the analog input signal swings out of phase with VCOM signal.

The 100% transmission is defined as the transmission of LCD panel when all the input terminals of module are electrically opened.

Note 6: Definition of color chromaticity (CIE 1931)

Color coordinates measured at the center point of LCD

Note 7: Measured at the center area of the panel when all the input terminals of LCD panel are electrically opened.

11. Reliability

Content of Reliability Test (Wide temperature, -20°C~70°C)

Environmental Test			
Test Item	Content of Test	Test Condition	Note
High Temperature storage	Endurance test applying the high storage temperature for a long time.	80°C 200hrs	2
Low Temperature storage	Endurance test applying the low storage temperature for a long time.	-30°C 200hrs	1,2
High Temperature Operation	Endurance test applying the electric stress (Voltage & Current) and the thermal stress to the element for a long time.	70°C 200hrs	—
Low Temperature Operation	Endurance test applying the electric stress under low temperature for a long time.	-20°C 200hrs	1
High Temperature/ Humidity Operation	The module should be allowed to stand at 60°C,90%RH max	60°C,90%RH 96hrs	1,2
Thermal shock resistance	The sample should be allowed stand the following 10 cycles of operation <div style="text-align: center;"> <p style="text-align: center;">-20°C 25°C 70°C</p> <p style="text-align: center;">30min 5min 30min</p> <p style="text-align: center;">1 cycle</p> </div>	-20°C/70°C 10 cycles	—
Vibration test	Endurance test applying the vibration during transportation and using.	Total fixed amplitude : 3 15mm Vibration Frequency : 10~55Hz One cycle 60 seconds to 3 directions of X,Y,Z for Each 15 minutes	3
Static electricity test	Endurance test applying the electric stress to the terminal.	VS=±600V(contact) ,±800v(air), RS=330Ω CS=150pF 10 times	—

Note1: No dew condensation to be observed.

Note2: The function test shall be conducted after 4 hours storage at the normal Temperature and humidity after remove from the test chamber.

Note3: The packing have to including into the vibration testing.

12.Display start address setting

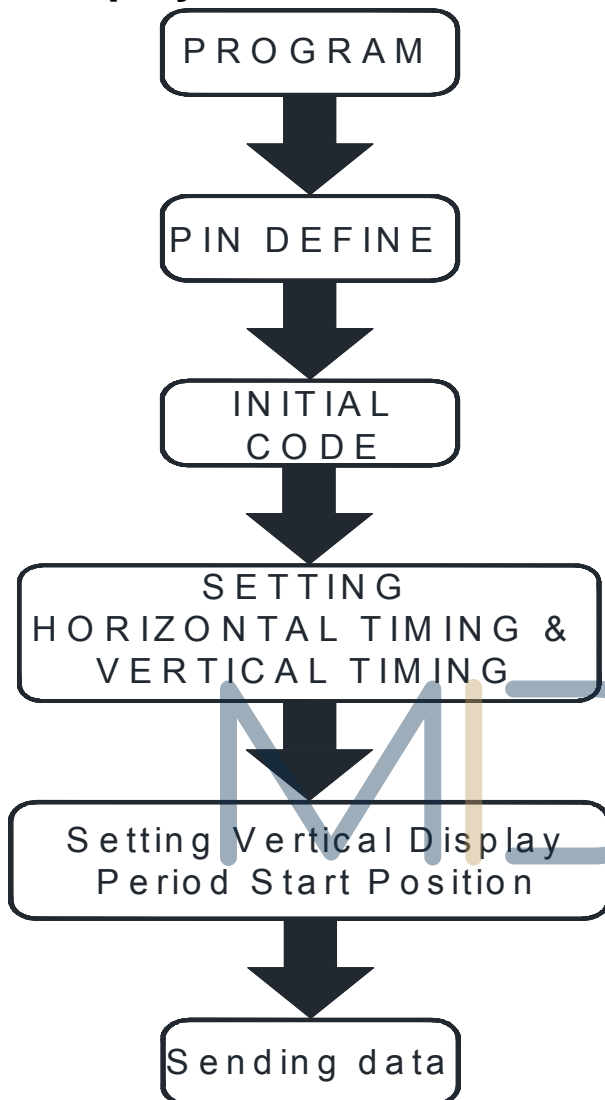

Ex.

One horizontal line=0x020d

VS period time=0x0120

HS Blanking=0x28

VS Blanking=0x08

HS Front Porch=0x05

VS Front Porch=0x08

Suggestion :
Vertical Display Period
Start Position=0x91

Note :

For different Controller ICs, the value of vertical display period start position need to be adjusted accordingly.