

ENERGIZER CR1216

Lithium Coin



Industry Standard Dimensions

mm (inches)



This Battery has Underwriters Laboratories component Recognition

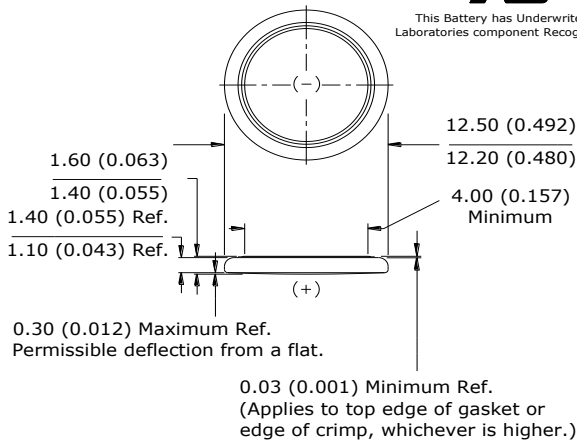

Simulated Application test

Typical Performance at 21°C (70°F)

Schedule:	Typical Drains: at 2.85V (mA)	Load (ohms)	Cutoff 2.0V (hours)
Continuous	0.046	62,000	739

Typical Discharge Characteristics

Load: 62,000 ohms - Continuous
Typical Drain @ 2.85V: 0.046 mA

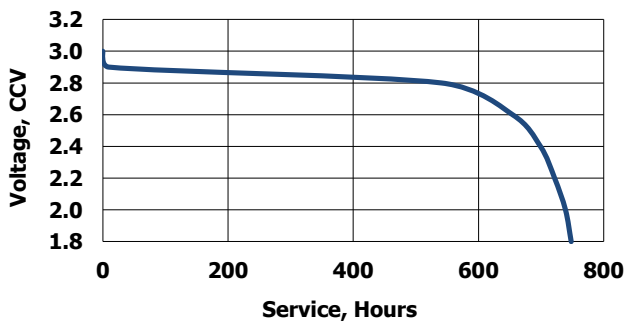

Specifications

Classification:	"Lithium Coin"
Chemical System:	Lithium / Manganese Dioxide (Li/MnO ₂)
Designation:	ANSI-5034LC, IEC-CR1216
Nominal Voltage:	3.0 Volts
Typical Capacity:	34 mAh (to 2.0 volts) (Rated at 62K ohms at 21°C)
Typical Weight:	0.6 grams (0.02 oz.)
Typical Volume:	0.2 cubic centimeters (0.01 cubic inch)
Max Rev Charge:	1 microampere
Energy Density:	118 milliwatt hr/g, 413 milliwatt hr/cc
Typical Li Content:	0.008 grams (0.0003 oz.)
UL Recognized:	MH29980
Operating Temp:	-30C to 70C
Self Discharge:	~1% / year

Safety:



(1) KEEP OUT OF REACH OF CHILDREN. Swallowing may lead to serious injury or death in as little as 2 hours due to chemical burns and potential perforation of the esophagus. **Immediately see doctor; have doctor phone (202) 625-3333.**

(2) Battery compartment design. To prevent children from removing batteries, battery compartments should be designed with one of the following methods: a) a tool such as screwdriver or coin is required to open battery compartment or b) the battery compartment door/cover requires the application of a minimum of two independent and simultaneous movements of the securing mechanism to open by hand. Screws should remain captive with the battery door or cover.

Internal Resistance Characteristics

Pulse Test at 21°C (70°F)

Bkgnd Drain: Continuous
62K ohms
0.046 mA @2.85V

Pulse Drain: 2 seconds X 12 times/day
1K ohms
2.8 mA @2.8V

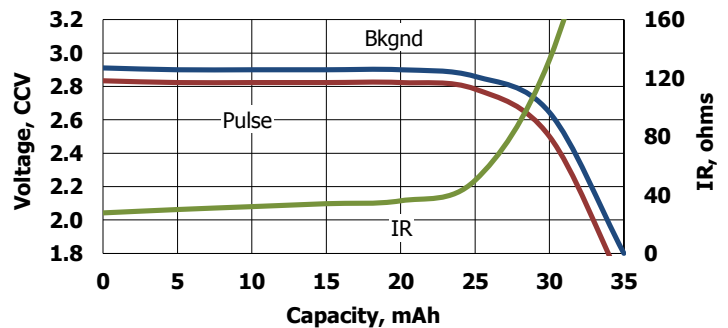

Pack Quantity : 1
Manufacturers Part Number : E300163400