

The supplier acknowledges that, with the acceptance of the drawings, he is in a position to manufacture the illustrated part in accordance with the drawings in reproducible form and series production. Through the selected manufacturing processes in compliance with the material and structure which could subsequently lead to an impairment of the components. Verbal agreements over and above that are not valid. Deviations from this rule must be written and must be signed by the purchaser.

Technische Daten/  
technical data : Akkupack/  
battery pack

Chemie/  
chemistry : Lithium Ion

Zellenzahl/  
no. of cells : 2 Zellen/ cells INR18650 LGC B4 ; 2S1P

Kapazität/  
capacity : nom. 2600mAh discharge at 0.2C  
min. 2500mAh discharge at 0.2C  
ta:20°C; EV(Discharge End Voltage): 2.75V per cell

Innenwiderstand/  
impedance : < 140mOhm (battery and safetyboard)

Nominalspannung/  
nominal voltage : 7.4V

Standard Ladespannung/  
standard charge voltage : 8.4V±1%

Standard Entladespannung/  
standard discharge voltage : 5.5V

Nominaler Ladestrom/  
nominal charge current : 0.5C

Maximaler Ladestrom/  
maximum charge current : 1C

Ladeendstrom/  
charge end current : 0.01C recommended

Maximaler Entladestrom/  
maximum discharge current : 5000mA (limited by safetyboard)

Anwendungstemperaturbereich/  
ambient temperature range : 0°C...+45°C charge  
-20°C...+60°C discharge  
-20°C...+30°C storage max. 1 year  
-20°C...+45°C storage max. 3months

Selbstentladung/  
self discharge : ≤ 5% / month at 20°C  
≤ 10% / month at 30°C  
≤ 20% / month at 40°C

Standards/  
 : UN 3480, Subsection 38.3  
All cells and battery packs type tested according to UN manual of test and criteria subsection 38.3

Technische Daten/  
technical data : Sicherheitsschaltung/  
safety board

Überladeschutzspannung/  
over charge voltage detection : 4.3V±25mV per cell

Wiedereinschaltspannung/  
over charge release voltage : 4.1V±50mV per cell

Entladeabschaltspannung/  
over discharge detection voltage : 2.4V±50mV per cell

Wiedereinschaltspannung/  
over discharge release voltage : 3V±100mV per cell

Nominaler Lade/Entladestrom/  
nominal operating current : 5A

Entlade Abschaltstrom/  
discharge cut off current : 13A± 3A

Kurzschlusschutz/  
short circuit protection : gegen äußeren Kurzschluss/  
against external short circuit

Temperaturumschalter/  
temperature switch : ---

MOSFET : in Masse  
in Gnd

Rückstellkriterium/  
release condition : Last trennen, Aktiv nach Anladen/  
cut load, release after charging up

Nettogewicht/  
net weight : ca./ approx. 100g

Leiterplattenmaterial/  
pcb material : FR4

Standards : CE

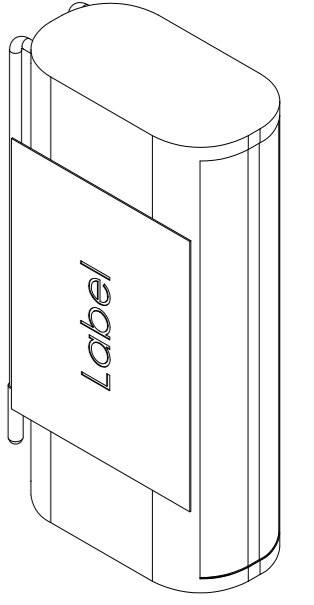
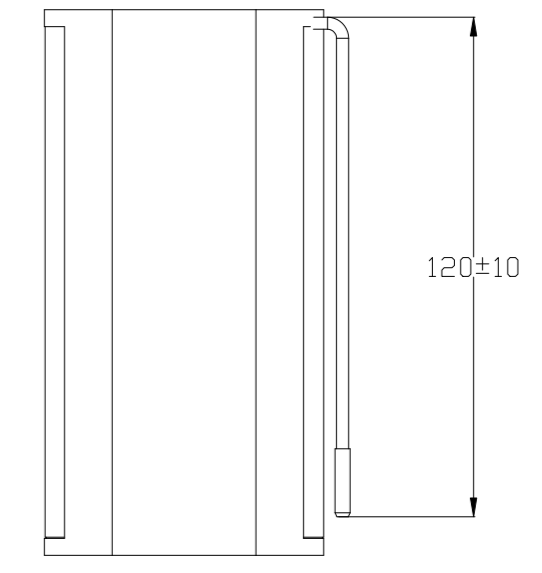
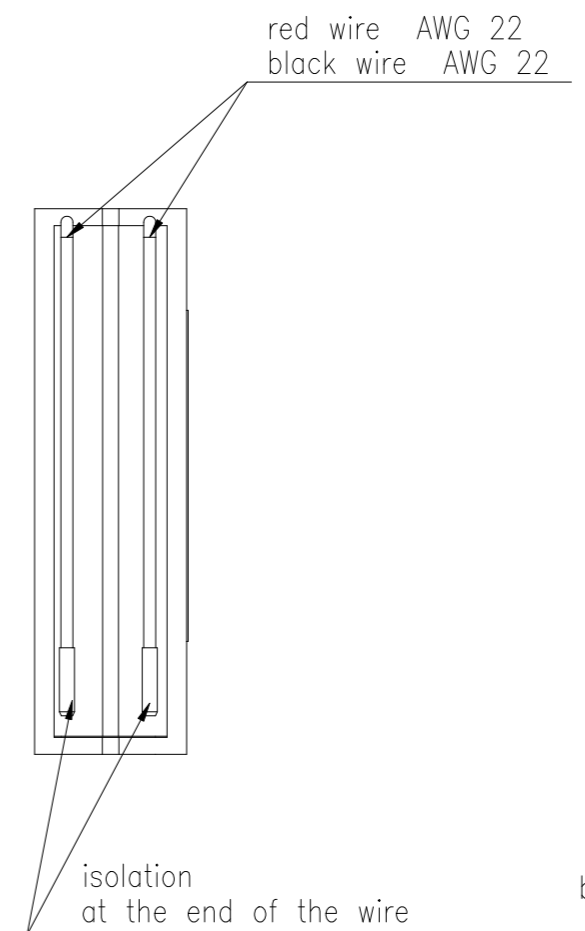
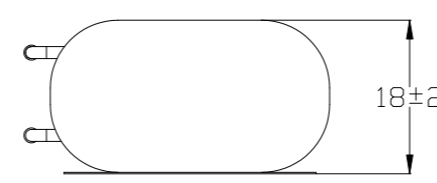
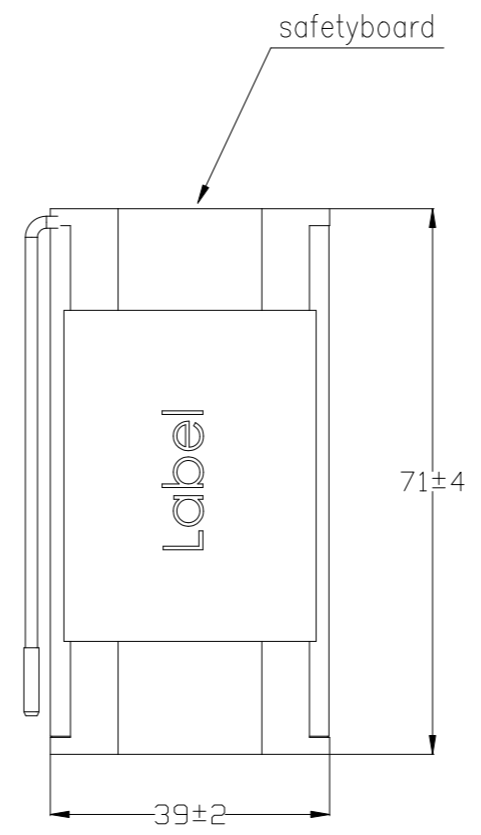
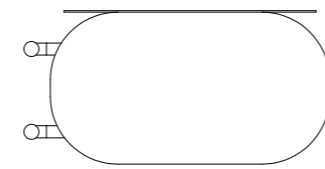

Verwendungsbereich/ Application range für Anfrage/for inquiry AN-IS-2013-00422		Zul. Abweichung/ Allowable deviation	Oberfläche/ Surface	Maßstab/Scale (DIN A2): 1:1	Gewicht/Weight
		Allgemeintoleranz DIN ISO 2768-m		Werkstoff/Work material, Modell-Nr.	
		2013	Datum/Date Name	Zeichnungsname/Drawing name	
		Erstellt/ Drawn by	23.10.	JE	Li-Ion Battery 7.4V 2600mAh with safetyboard
V2	changed cell description	18.12.17	DS	Zeichnungsnummer/Drawing number	
V1	change request: DE-15-0022	15.01.16	MSI	Artikelnummer/Part number	
VO	technical data corrected	24.06.15	JH	2447-3030-01	
Version	Änderung/Change	Datum/Date	Name	Ursprung/Origin Proj. IS-2013-00422	Ersatz für/Replaced by
				Ersatz durch/Replacement through:	

