

Active infrared (area reflective) human detection sensor MA MOTION SENSOR

Discontinued

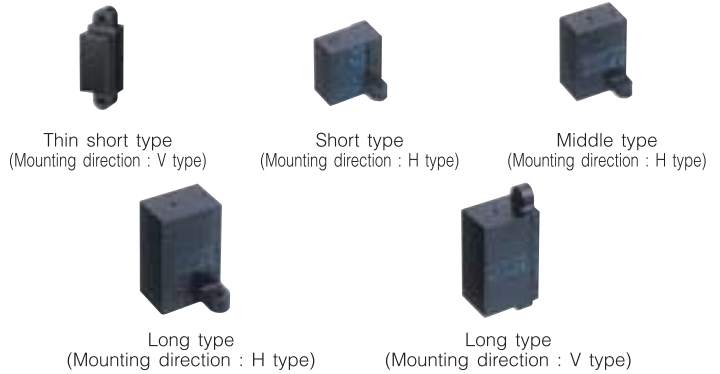

Features

- Reliable detection hardly influenced by reflectivity of targeted objects
- Ready-to-use with DC power source (built-in oscillation circuit type)
- Capability to adjoin sensors (External triggering type)
- RoHS compliant

Typical applications

- Equipment around water: automatic lighting of wash-units, toilets, automatic flush
- Stores and financial markets: automatic doors, lighting, ATM, visitor sensors
- Amusement equipment: seating detection for pachinko machines, game displays
- Medical equipment markets: noncontact switches

Ordering information

AM

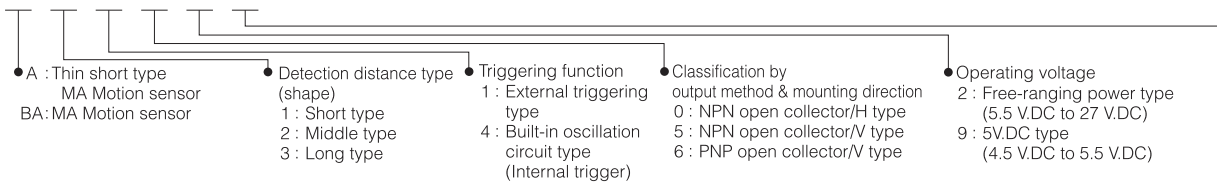

● Rated detection distance

Unit : cm inch

Part No. Type	02	03	04	05	06	07	08 (Middle type does not need 08)	09	10 (Short type does not need 10)	11	12	13	14	15	16	17	18	19	20 (Long type does not need 20)
Thin short type	-	-	-	5 1.969	-	-	-	-	10 3.937	-	-	-	-	15 5.906	-	-	-	-	-
Short type	-	-	-	5 1.969	6 2.362	7 2.756	8 3.150	9 3.543	10 3.937	-	-	-	-	-	-	-	-	-	-
Middle type	20 7.874	30 11.811	40 15.748	50 19.685	60 23.622	70 27.559	80 31.496	-	-	-	-	-	-	-	-	-	-	-	-
Long type	-	30 11.811	40 15.748	50 19.685	60 23.622	70 27.559	80 31.496	90 35.443	100 39.37	110 43.307	120 47.244	130 51.181	140 55.118	150 59.055	160 62.992	170 66.929	180 70.866	190 74.803	200 78.74

Product types

- Detection distance type (distance limited)
 - 1) Thin short type (V type)

Standard packing: Carton: 20 pcs.; Case: 200 pcs.

Operating voltage	Output method	Rated detection distance	Built-in oscillation circuit type	External triggering type
			Part No.	Part No.
4.5 V.DC to 5.5 V.DC	NPN open collector output	5 cm 1.969 inch	AMA145905	AMA115905
		10 cm 3.937 inch	AMA1459	AMA1159
		15 cm 5.906 inch	AMA145915	AMA115915
	PNP open collector output	5 cm 1.969 inch	AMA146905	AMA116905
		10 cm 3.937 inch	AMA1469	AMA1169
		15 cm 5.906 inch	AMA146915	AMA116915

Note: If using multiple sensors adjacently or reducing power consumption, contact us for the optimal external trigger type.

- 2) Short type (H type)

Standard packing: Carton: 20 pcs.; Case: 200 pcs.

Rated operating voltage	Rated detection distance	Mounting direction : H type	
		Short type	
		Built-in oscillation circuit type	External triggering type
		Part No.	Part No.
4.5 V.DC to 5.5 V.DC	5 cm 1.969 inch	AMBA140905	AMBA110905
	6 cm 2.362 inch	AMBA140906	AMBA110906
	7 cm 2.756 inch	AMBA140907	AMBA110907
	8 cm 3.150 inch	AMBA140908	AMBA110908
	9 cm 3.543 inch	AMBA140909	AMBA110909
	10 cm 3.937 inch	AMBA1409	AMBA1109
5.5 V.DC to 27 V.DC	5 cm 1.969 inch	AMBA140205	AMBA110205
	6 cm 2.362 inch	AMBA140206	AMBA110206
	7 cm 2.756 inch	AMBA140207	AMBA110207
	8 cm 3.150 inch	AMBA140208	AMBA110208
	9 cm 3.543 inch	AMBA140209	AMBA110209
	10 cm 3.937 inch	AMBA1402	AMBA1102

Note: If using multiple sensors adjacently or reducing power consumption, contact us for the optimal external trigger type.

- 3) Middle type (H type)

Standard packing: Carton: 20 pcs.; Case: 200 pcs.

Rated operating voltage	Rated detection distance	Mounting direction : H type	
		Middle type	
		Built-in oscillation circuit type	External triggering type
		Part No.	Part No.
4.5 V.DC to 5.5 V.DC	20 cm 7.874 inch	AMBA240902	AMBA210902
	30 cm 11.811 inch	AMBA240903	AMBA210903
	40 cm 15.748 inch	AMBA240904	AMBA210904
	50 cm 19.685 inch	AMBA240905	AMBA210905
	60 cm 23.622 inch	AMBA240906	AMBA210906
	70 cm 27.559 inch	AMBA240907	AMBA210907
	80 cm 31.496 inch	AMBA2409	AMBA2109
5.5 V.DC to 27 V.DC	20 cm 7.874 inch	AMBA240202	AMBA210202
	30 cm 11.811 inch	AMBA240203	AMBA210203
	40 cm 15.748 inch	AMBA240204	AMBA210204
	50 cm 19.685 inch	AMBA240205	AMBA210205
	60 cm 23.622 inch	AMBA240206	AMBA210206
	70 cm 27.559 inch	AMBA240207	AMBA210207
	80 cm 31.496 inch	AMBA2402	AMBA2102

Note: If using multiple sensors adjacently or reducing power consumption, contact us for the optimal external trigger type.

4) Long type

Standard packing: Carton: 20 pcs.; Case: 200 pcs.

Rated operating voltage	Rated detection distance	Mounting direction : H type		Mounting direction: V type	
		Long type			
		Built-in oscillation circuit type	External triggering type	Built-in oscillation circuit type	External triggering type
		Part No.	Part No.	Part No.	Part No.
4.5 V.DC to 5.5 V.DC	30 cm 11.811 inch	AMBA340903	AMBA310903	AMBA345903	AMBA315903
	40 cm 15.748 inch	AMBA340904	AMBA310904	AMBA345904	AMBA315904
	50 cm 19.685 inch	AMBA340905	AMBA310905	AMBA345905	AMBA315905
	60 cm 23.622 inch	AMBA340906	AMBA310906	AMBA345906	AMBA315906
	70 cm 27.559 inch	AMBA340907	AMBA310907	AMBA345907	AMBA315907
	80 cm 31.496 inch	AMBA340908	AMBA310908	AMBA345908	AMBA315908
	90 cm 35.433 inch	AMBA340909	AMBA310909	AMBA345909	AMBA315909
	100 cm 39.370 inch	AMBA340910	AMBA310910	AMBA345910	AMBA315910
	110 cm 43.307 inch	AMBA340911	AMBA310911	AMBA345911	AMBA315911
	120 cm 47.244 inch	AMBA340912	AMBA310912	AMBA345912	AMBA315912
	130 cm 51.181 inch	AMBA340913	AMBA310913	AMBA345913	AMBA315913
	140 cm 55.118 inch	AMBA340914	AMBA310914	AMBA345914	AMBA315914
	150 cm 59.055 inch	AMBA340915	AMBA310915	AMBA345915	AMBA315915
	160 cm 62.992 inch	AMBA340916	AMBA310916	AMBA345916	AMBA315916
	170 cm 66.929 inch	AMBA340917	AMBA310917	AMBA345917	AMBA315917
	180 cm 70.866 inch	AMBA340918	AMBA310918	AMBA345918	AMBA315918
190 cm 74.803 inch	AMBA340919	AMBA310919	AMBA345919	AMBA315919	
200 cm 78.740 inch	AMBA3409	AMBA3109	AMBA3459	AMBA3159	
5.5 V.DC to 27 V.DC	30 cm 11.811 inch	AMBA340203	AMBA310203	AMBA345203	AMBA315203
	40 cm 15.748 inch	AMBA340204	AMBA310204	AMBA345204	AMBA315204
	50 cm 19.685 inch	AMBA340205	AMBA310205	AMBA345205	AMBA315205
	60 cm 23.622 inch	AMBA340206	AMBA310206	AMBA345206	AMBA315206
	70 cm 27.559 inch	AMBA340207	AMBA310207	AMBA345207	AMBA315207
	80 cm 31.496 inch	AMBA340208	AMBA310208	AMBA345208	AMBA315208
	90 cm 35.433 inch	AMBA340209	AMBA310209	AMBA345209	AMBA315209
	100 cm 39.370 inch	AMBA340210	AMBA310210	AMBA345210	AMBA315210
	110 cm 43.307 inch	AMBA340211	AMBA310211	AMBA345211	AMBA315211
	120 cm 47.244 inch	AMBA340212	AMBA310212	AMBA345212	AMBA315212
	130 cm 51.181 inch	AMBA340213	AMBA310213	AMBA345213	AMBA315213
	140 cm 55.118 inch	AMBA340214	AMBA310214	AMBA345214	AMBA315214
	150 cm 59.055 inch	AMBA340215	AMBA310215	AMBA345215	AMBA315215
	160 cm 62.992 inch	AMBA340216	AMBA310216	AMBA345216	AMBA315216
	170 cm 66.929 inch	AMBA340217	AMBA310217	AMBA345217	AMBA315217
	180 cm 70.866 inch	AMBA340218	AMBA310218	AMBA345218	AMBA315218
190 cm 74.803 inch	AMBA340219	AMBA310219	AMBA345219	AMBA315219	
200 cm 78.740 inch	AMBA3402	AMBA3102	AMBA3452	AMBA3152	

Note: If using multiple sensors adjacently or reducing power consumption, contact us for the optimal external trigger type.

Rating

● Detection performance

1) Thin short type (Measuring conditions: ambient temp. : 25 °C 77 °F; operating voltage : 5 V.DC)

Items		Unit	Thin short type			Measured conditions	
			cm	inch	mm		
Rated detection distance	Minimum	mm inch	45	1.772	90	3.543	with a standard reflection board *1
	Typical		100	3.937	150	5.906	
	Maximum		110	4.331	165	6.496	
Measuring tolerance	Typical	%	10		25	35	Reflection rate: 90 % to 18 %
Usable ambient brightness (Resistance to ambient light) *2	Brightness of sensor surface	lx	30,000			See the drawing (Fig. 1) on the Brightness next page.	
	Brightness of reflection surface		24,000				

Notes : *1. Ambient brightness: 500 lx

*2. Prevent direct light (within 30 ° against the optical axis of the sensor) from entering into the sensor.

2) Short type (Measuring conditions : ambient temp.: 25 °C 77 °F; operating voltage: 5 V.DC type 5 V.DC, Free-ranging power type 24 V.DC)

Items		Unit		Short type *1					Measured conditions	
		cm	inch	5	6	7	8	9		10
Rated detection distance	Minimum	mm	inch	45	54	63	72	81	90	with a standard reflection board
	Typical			1.772	2.126	2.480	2.835	3.189	3.543	
	Maximum			50	60	70	80	90	100	
Measuring tolerance		Typical	%	10		15	20		25	Reflection rate: 90 % to 18 %
Usable ambient brightness (Resistance to ambient light) *2	Brightness of sensor surface	Maximum	lx	30,000					See the drawing (Fig. 1) on the next page.	
	Brightness of reflection surface	Maximum		24,000						

Notes : *1. After the order receipt, the average rated detecting distance can be increased to max 15 cm 5.906 inch. Please consult us.

*2. Prevent direct light (within 30 ° against the optical axis of the sensor) from entering into the sensor.

3) Middle type (Measuring conditions: ambient temp.: 25 °C 77 °F; operating voltage: 5 V.DC type 5 V.DC, Free-ranging power type 24 V.DC)

Items		Unit		Middle type *1					Measured conditions		
		cm	inch	20	30	40	50	60		70	80
Rated detection distance	Minimum	mm	inch	190	285	380	475	570	665	760	with a standard reflection board
	Typical			7.480	11.220	14.961	18.701	22.441	26.181	29.921	
	Maximum			200	300	400	500	600	700	800	
Measuring tolerance		Typical	%	3		5		10		Reflection rate: 90 % to 18 %	
Usable ambient brightness (Resistance to ambient light) *2	Brightness of sensor surface	Maximum	lx	30,000					See the drawing (Fig. 1) on the next page.		
	Brightness of reflection surface	Maximum		24,000							

Notes : *1. After the order receipt, the average rated detecting distance can be increased to max 110 cm 43.307 inch. Please consult us.

*2. Prevent direct light (within 30 ° against the optical axis of the sensor) from entering into the sensor.

4) Long type (Measuring conditions: ambient temp.: 25 °C 77 °F; operating voltage: 5 V.DC type 5 V.DC, Free-ranging power type 24 V.DC)

Items		Unit		Long type							Measured conditions		
		cm	inch	30	40	50	60	70	80	90		100	110
Rated detection distance	Minimum	mm	inch	285	380	475	570	665	760	855	950	1045	with a standard reflection board
	Typical			11.220	14.961	18.701	22.441	26.181	29.921	33.661	37.402	41.142	
	Maximum			300	400	500	600	700	800	900	1000	1100	
Measuring tolerance		Typical	%	3				5			Reflection rate: 90 % to 18 %		
Usable ambient brightness (Resistance to ambient light) *	Brightness of sensor surface	Maximum	lx	30,000							See the drawing (Fig. 1) on the next page.		
	Brightness of reflection surface	Maximum		24,000									

Items		Unit		Long type							Measured conditions		
		cm	inch	120	130	140	150	160	170	180		190	200
Rated detection distance	Minimum	mm	inch	1140	1235	1330	1425	1520	1615	1710	1805	1900	with a standard reflection board
	Typical			44.882	48.622	52.362	56.102	59.842	63.583	67.323	71.063	74.803	
	Maximum			1200	1300	1400	1500	1600	1700	1800	1900	2000	
Measuring tolerance		Typical	%	5	10			15				Reflection rate: 90 % to 18 %	
Usable ambient brightness (Resistance to ambient light) *	Brightness of sensor surface	Maximum	lx	30,000							See the drawing (Fig. 1) on the next page.		
	Brightness of reflection surface	Maximum		24,000									

Notes : * Prevent direct light (within 30 ° against the optical axis of the sensor) from entering into the sensor.

- For thin short type:
Standard reflection board : 150 mm 5.906 inch square area, 90% reflection rate.
- For short type:
Standard reflection board: 100 mm 3.937 inch square area, 90% reflection rate.
- For middle type:
Standard reflection board: 200 mm 7.874 inch square area, 90% reflection rate.
- For long type:
Standard reflection board: 500 mm 19.685 inch square area, 90% reflection rate.

Notes : 1. Detecting an object within the maximum preset detection distance.

$$2. \text{Distance deviation} = \frac{a-b}{a} \times 100 (\%)$$

(a: detection distance of detection target with reflectance of 90 %.
b: detection distance of standard detection target with reflectance of 18 %.)

<Fig. 1>
[Brightness of sensor surface]

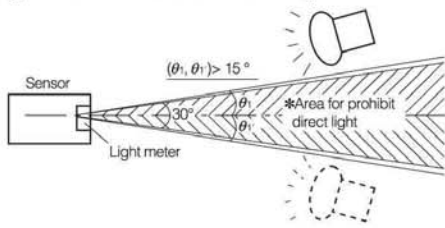

Notes : If sunlight or strobe/inverter light (including the regular reflection light from glasses and mirrors) directly enters from the inhibition area, those lights may cause malfunction of the sensor.

[Brightness of reflection surface]

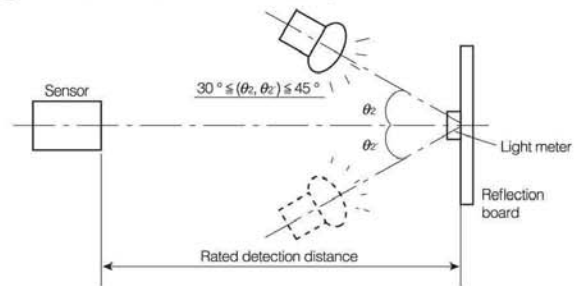

Absolute maximum rating

● Measuring condition: ambient temp.: 25 °C 77 °F

Items	Absolute maximum rating			
	Built-in oscillation circuit type		External triggering type	
	5 V.DC type	Free-ranging power type	5 V.DC type	Free-ranging power type
Power supply voltage	-0.3 V.DC to 6.0 V.DC	-0.3 V.DC to 30 V.DC	-0.3 V.DC to 6.0 V.DC	-0.3 V.DC to 30 V.DC
Output dielectric strength	30 V.DC		30 V.DC	
Output flow current	100 mA		10 mA*	
Usable ambient temperature	-25 °C to +75 °C +5 °F to +131 °F (No freezing)		-25 °C to +75 °C +5 °F to +131 °F (No freezing)	
Storage temperature	-30 °C to +85 °C -4 °F to +176 °F		-30 °C to +85 °C -4 °F to +176 °F	

Notes : * Thin short type is only: 100 mA

Electrical characteristics

● Measuring conditions : ambient temp.: 25 °C 77 °F, operating voltage: 5 V.DC type, free-ranging power type 24 V.DC

1) Built-in oscillation circuit type

Items	Symbol	Thin short type*		Short type	Middle type	Long type	Measured conditions
		NPN output type	PNP output type				
Rated operating voltage	Minimum	5.0 V.DC type : 4.5V.DC / Free-ranging power type : 5.5 V.DC					
	Typical	-					
	Maximum	5.0 V.DC type : 5.5 V.DC /Free-ranging power type : 27 V.DC					
Average current consumption (I _{out} =0 mA)	No detection	I _t	-		5.0 V.DC type : 4.5 mA Free-ranging power type : 5.6 mA		
			Typical	4.5 mA			
			Maximum	6.2 mA			
	Detection	I _t	-		5.0 V.DC type : 7.0 mA Free-ranging power type : 9.1 mA		
			Typical	7.0 mA			11.0 mA
			Maximum	11.2 mA			15.2 mA
Measuring cycle	Typical	T	8 ms/cycle				
Output characteristics	Remain voltage	Maximum	V _r	1.0 V.DC	1.2 V.DC	1.0 V.DC	I _t =100 mA
	Leakage current	Maximum	I _l	5 μA		3 μA	V=30 V.DC

Notes : * The thin short type is only available for 5 V.DC.

2) External triggering type (trigger conditions: trigger pulse width = 20 μs and trigger synchronization = 5 ms)

Items		Symbol	Thin short type*1		Short type	Middle type	Long type	Measured conditions	
			NPN output type	PNP output type					
Rated operating voltage		Minimum	5.0 V.DC type : 4.5 V.DC / Free-ranging type : 5.5 V.DC						
		Typical	-						
		Maximum	5.0 V.DC type : 5.5 V.DC / Free-ranging type : 27 V.DC						
Average current consumption	Without trigger input	Output OFF	Minimum	-					*2 ♣b
			Typical	Ib		5.0 V.DC type: 0.1 mA/Free-ranging type: 1.0 mA			
			Maximum	Ib		5.0 V.DC type: 0.3 mA/Free-ranging type: 1.8 mA			
		Output ON	Minimum	-					
			Typical	Id		5.0 V.DC type: 0.5 mA/Free-ranging type: 1.4 mA			
			Maximum	Id		5.0 V.DC type: 3.4 mA/Free-ranging type: 4.5 mA			
	With trigger input	Output OFF	Minimum	-					*2 ♣a
			Typical	Ia		5.0 V.DC type: 2.2 mA/Free-ranging type: 3.1 mA			
			Maximum	Ia		5.0 V.DC type: 6.2 mA/Free-ranging type: 7.2 mA			
		Output ON	Minimum	-					
			Typical	Ic		5.0 V.DC type: 2.4 mA/Free-ranging type: 3.3 mA			
			Maximum	Ic		5.0 V.DC type: 8.2 mA/Free-ranging type: 9.3 mA			
Measuring cycle (Trigger interval)		Typical	Tt	5 ms/cycle					
External trigger	Pulse width	Minimum	20 μs					Half off the distance period	
		Maximum	Tw		1/2 Tt				
	Level	Minimum	V _{TL}	0.8 V					
		Maximum	V _{TH}	3 V				*3	
Response performance: time from trigger pulse fall to detection output		Typical	Tr	5 ms					
Output characteristics	Remain voltage	Minimum	Vr	1.0 V.DC	1.2 V.DC	1.0 V.DC		It=10 mA	
	Leakage current	Maximum	Ii	5 μA		3 μA		V=30 V.DC	

Notes : *1. The thin short type is only available for 5.0 V.DC.

*2. The ratio between the 4 operating modes (♣a to ♣d) depends on the external trigger period and detector time, and the current consumption corresponds with this varying ratio.

*4. The output transistor is open collector.

The output transistor is turned ON by the sensor detection status and turned OFF by its non-detection status.

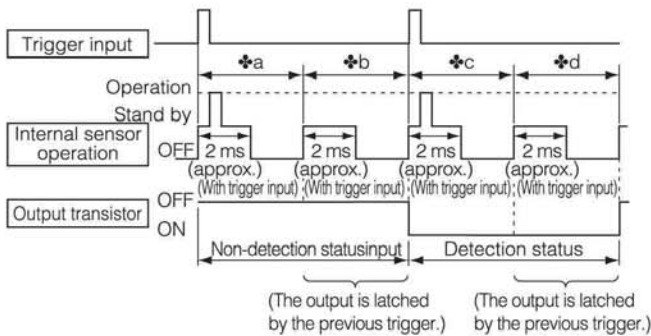

*3. A high level is established in the open state due to pull-up by the internal circuit. (Refer to the connector wiring diagram.)

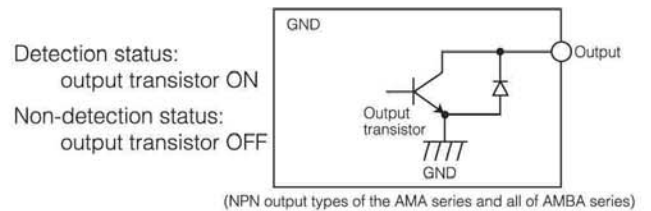

(NPN output types of the AMA series and all of AMBA series)

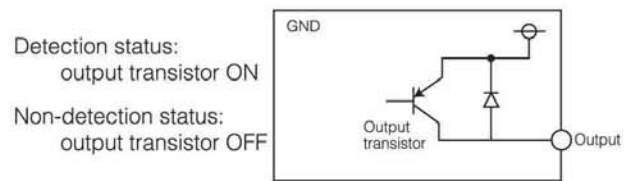

(PNP output types of the AMA series)

Timing chart

● Built-in oscillation circuit type

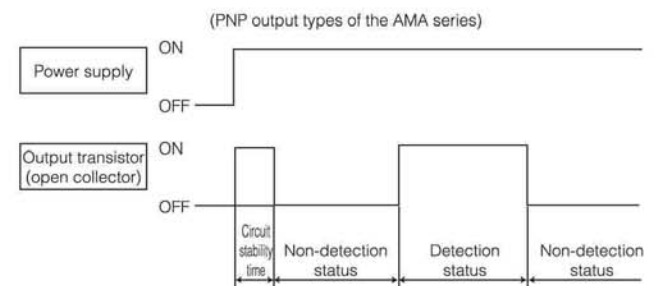
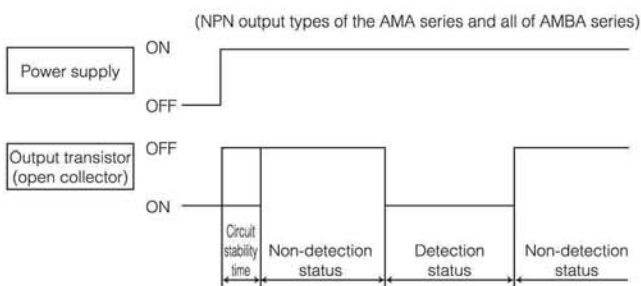

Notes : *1. Circuit stability time : Max. 12 ms

*2. During the time taken for the circuit to stabilize after the power is turned on, the ON/OFF status of the output transistor is not determined by whether the sensor is in the detection status or non-detection status.

External triggering type

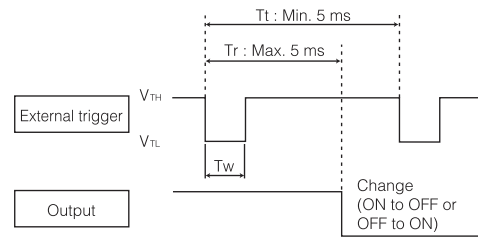
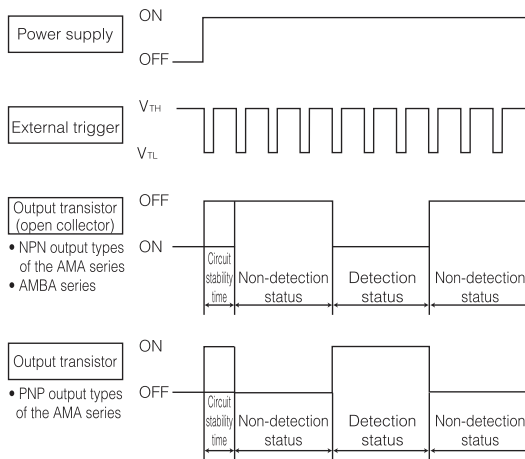

Notes : The sensor recognizes at the $V_{TH} \rightarrow V_{TL}$ edge of an external trigger that the external trigger has been input.

- Notes :
- *1. Circuit stability time: Max. 12 ms
 - *2. During the time taken for the circuit to stabilize after the power is turned on, the ON/OFF status of the output transistor is not determined by whether the sensor is in the detection status or non-detection status.

How to use

Wiring diagram of connector

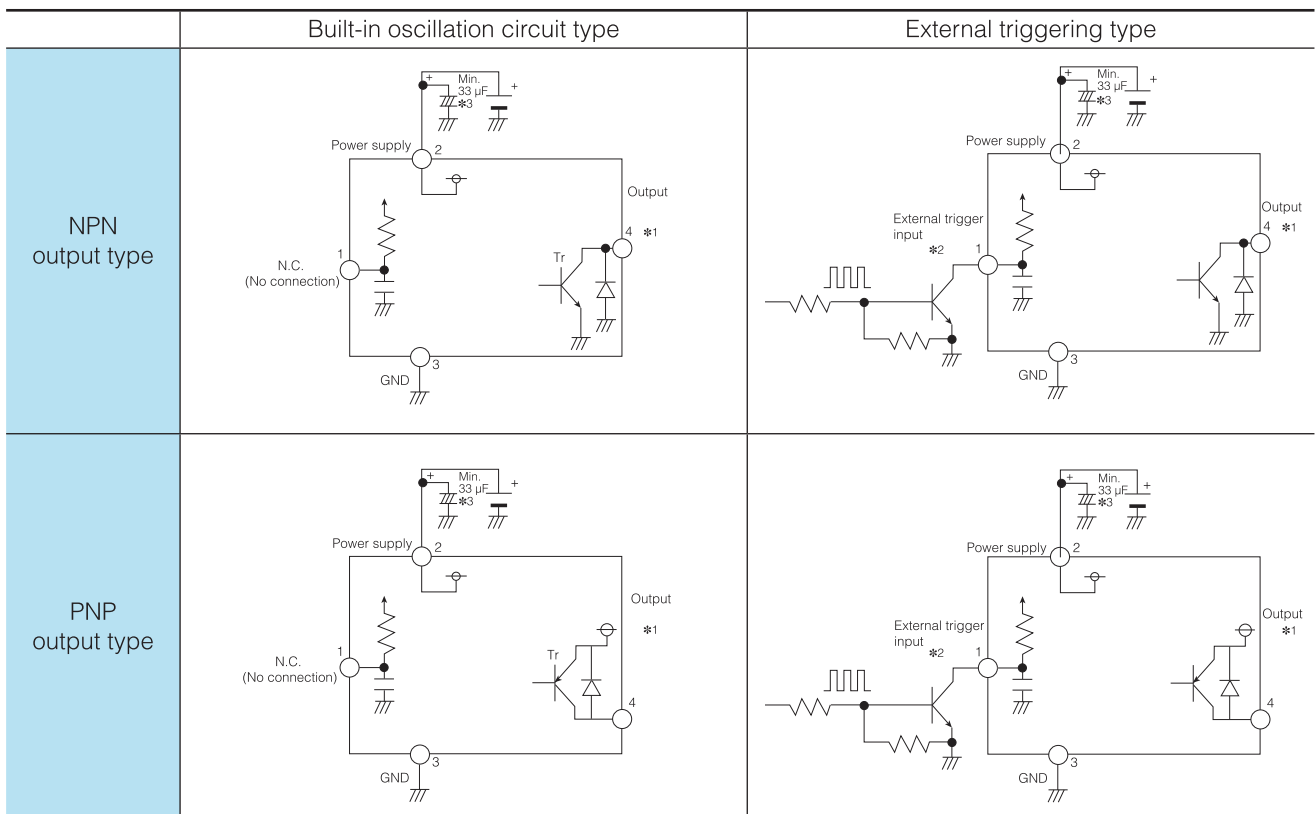

- Notes :
- *1. The output transistor has an open collector structure.
 - Detection status: Output transistor ON (connected to GND)
 - Non-detection status: Output transistor OFF (open state)
 - *2. The status of the external trigger input is as follows:
 - Open at the high level
 - GND (less than 0.8 V) at the low level
 - Do not apply a high voltage.
 - *3. Install capacitor (of 33 μ F or over) on the power input terminal of the sensor in order to secure power superimposed noise resistance and stabilize the power supply voltage.

Reference data

Operating region characteristics

How to interpret the graph

Example: Operating area of the Short Type with rated detection distance of 8 cm 3.150 inch.

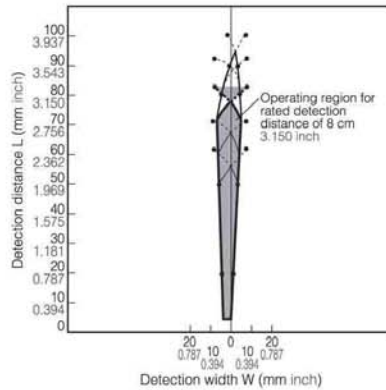

Operating area within the dotted lines

Objects that enter the entire area are detected.

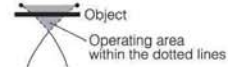

Note: If only part of the object is in the detection area, it is not detected.

Operating area within the solid lines

Objects that even partially enter the area are detected.

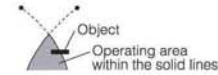

1.-(1) Thin short type (AMA1□□□□□) Short type (AMBA1□□□□□)

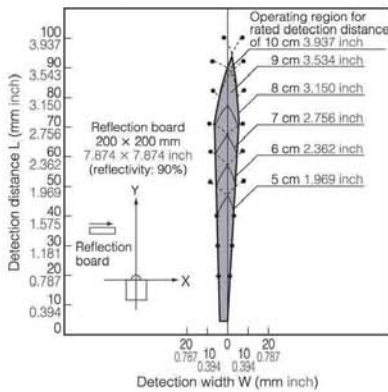

1.-(2) Middle type (AMBA2□□□□□)

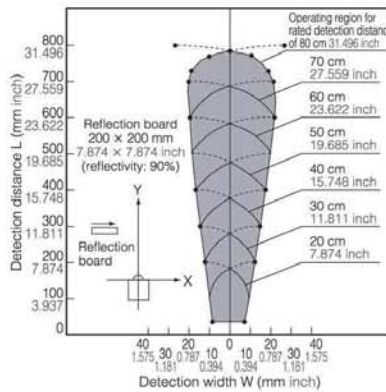

1.-(3) Long type (AMBA3□□□□□)

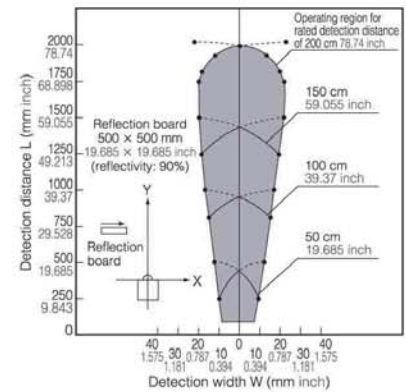

Dimensions

The CAD data of the products with a **CAD Data** mark can be downloaded from: <http://industrial.panasonic.com/>

(Common to the Built-in oscillation circuit type and External triggering type)

Thin short type (V type)

CAD Data

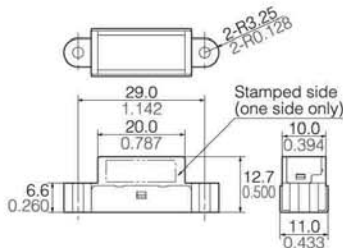

* Rear side connector protrusion: Max. 0.4mm

Short type (H type)

CAD Data

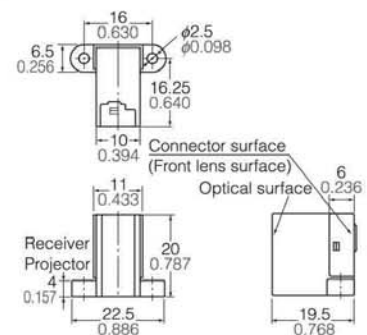

Middle type (H type)

CAD Data

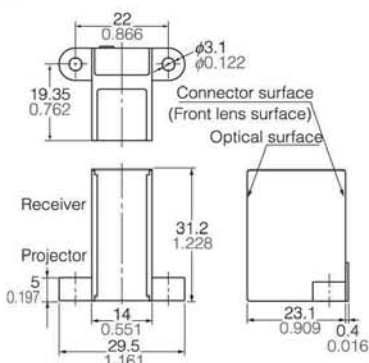

unit : mm inch

(Common to the Built-in oscillation circuit type and External triggering type)

● Long type (H type)

CAD Data

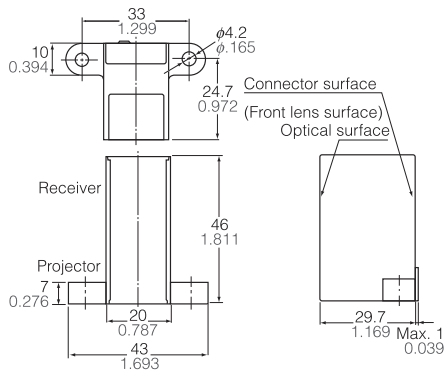

● Long type (V type)

CAD Data

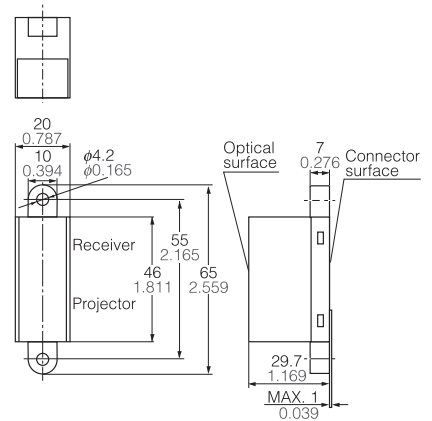

unit : mm inch

Wiring diagram (Connector surface view)

● Thin short type (V type)

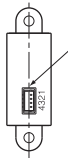

BM04B-SRSS
(J.S.T. Mfg. Co., Ltd.)
1: Output
2: GND
3: Power source
4: Built-in oscillation circuit type: N.C.
External triggering type:
external trigger input

● Short type (H type)

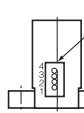

DF13-4P-1.25DS(20)
(HIROSE ELECTRIC CO., LTD.)
4: Output
3: GND
2: Power source
1: Built-in oscillation circuit type: N.C.
External triggering type:
external trigger input

● Middle type (H type)

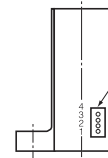

DF13-4P-1.25DSA
(HIROSE ELECTRIC CO., LTD.)
4: Output
3: GND
2: Power source
1: Built-in oscillation circuit type: N.C.
External triggering type:
external trigger input

● Long type (H type)

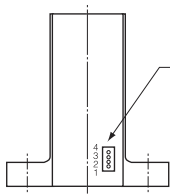

DF13-4P-1.25DSA
(HIROSE ELECTRIC CO., LTD.)
4: Output
3: GND
2: Power source
1: Built-in oscillation circuit type: N.C.
External triggering type:
external trigger input

● Long type (V type)

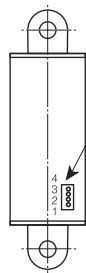

DF13-4P-1.25DSA
(HIROSE ELECTRIC CO., LTD.)
4: Output
3: GND
2: Power source
1: Built-in oscillation circuit type: N.C.
External triggering type:
external trigger input

Options

● Connector with cable (for Short, Middle and Long type)
AMV9003

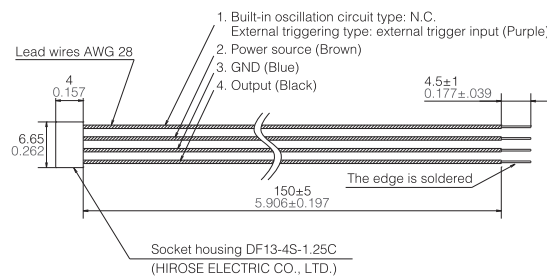

unit : mm inch

● Connector with cable (for Thin short type)
AMV9002

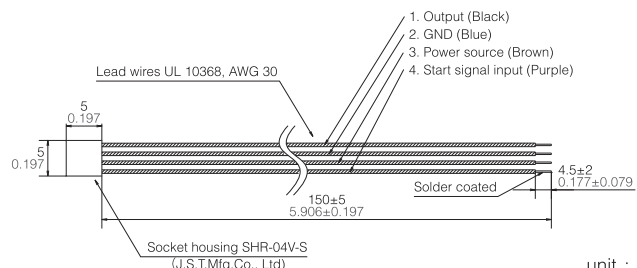

unit : mm inch

Safety and Legal Matters to Be Observed

Product specifications and applications

- Please be advised that this product and product specifications are subject to change without notice for improvement purposes. Therefore, please request and confirm the latest delivery specifications that explain the specifications in detail before the final design, or purchase or use of the product, regardless of the application. In addition, do not use this product in any way that deviates from the contents of the company's delivery specifications.
- Unless otherwise specified in this catalog or the product specifications, this product is intended for use in general electronic equipment (AV products, home appliances, commercial equipment, office equipment, information and communication equipment, etc.).
When this product is used for the following special cases, the specification document suited to each application shall be signed/sealed (with Panasonic Industry and the user) in advance..These include applications requiring special quality and reliability, wherein their failures or malfunctions may directly threaten human life or cause harm to the human body (e.g.: space/aircraft equipment, transportation/traffic equipment, combustion equipment, medical equipment, disaster prevention/crime prevention equipment, safety equipment, etc.).

Safety design and product evaluation

- Please ensure safety through protection circuits, redundant circuits, etc., in the customer's system design so that a defect in our company's product will not endanger human life or cause other serious damage.
- This catalog shows the quality and performance of individual parts. The durability of parts varies depending on the usage environment and conditions. Therefore, please ensure to evaluate and confirm the state of each part after it has been mounted in your product in the actual operating environment before use.
If you have any doubts about the safety of this product, then please notify us immediately, and be sure to conduct a technical review including the above protection circuits and redundant circuits at your company.

Laws / Regulations / Intellectual property

- The transportation of dangerous goods as designated by UN numbers, UN classifications, etc., does not apply to this product. In addition, when exporting products, product specifications, and technical information described in this catalog, please comply with the laws and regulations of the countries to which the products are exported, especially those concerning security export control.
- Each model of this product complies with the RoHS Directive (Restriction of the use of hazardous substances in electrical and electronic equipment) (2011/65/EU and (EU) 2015/863). The date of compliance with the RoHS Directive and REACH Regulation varies depending on the product model.
Further, if you are using product models in stock and are not sure whether or not they comply with the RoHS Directive or REACH Regulation, please contact us by selecting "Sales Inquiry" from the inquiry form.
- During the manufacturing process of this product and any of its components and materials to be used, Panasonic Industry does not intentionally use ozone-depleting substances stipulated in the Montreal Protocol and specific bromine-based flame retardants such as PBBs (Poly-Brominated Biphenyls) / PBDEs (Poly-Brominated Diphenyl Ethers). In addition, the materials used in this product are all listed as existing chemical substances based on the Act on the Regulation of Manufacture and Evaluation of Chemical Substances.
- With regard to the disposal of this product, please confirm the disposal method in each country and region where it is incorporated into your company's product and used.
- The technical information contained in this catalog is intended to show only typical operation and application circuit examples of this product. This catalog does not guarantee that such information does not infringe upon the intellectual property rights of Panasonic Industry or any third party, nor imply that the license of such rights has been granted.
- Design, materials, or process related to technical owned by Panasonic Industry are subject to change without notice.

Panasonic Industry will assume no liability whatsoever if the use of our company's products deviates from the contents of this catalog or does not comply with the precautions. Please be advised of these restrictions.

Notes

■ Use environment

- 1) Avoid use in the steamy or dusty environment, the corrosive gas, an environment where organic solvent can be adhered.
- 2) When using in a high-noise environment, perform countermeasures such as installing capacitor (of 33 μ F or over) on the power input terminal of the sensor. Before use, check the performance under actual use conditions.

■ Wire connection

- 1) Before the power is supplied, recheck wiring as misconnection may damage the internal circuit. (ensure to avoid reverse connection)
- 2) Use wires shorter than 3 m 9.842 ft to protect the internal circuit. Before use, check under actual use conditions if there is no influence by surrounding environments.
- 3) Do not repeatedly attach/detach the connector.

■ Detecting part

- 1) Keep the detecting surface clean. The detecting surface is resistant to trash/ dust, however, if an excessive amount of trash/dust adhere to the surface, it may reduce the margin of detecting distance.
- 2) Dew condensation on the detecting surface may cause malfunction.
- 3) The sensor aims to detect human bodies. If the targeted object has extremely low reflectivity (e.g., objects frosted by black rubbers) or extremely high reflectivity (e.g., objects which regularly reflect: mirrors, glasses or glossy papers), the sensor may not be able to detect or the detecting distance may become unstable.
- 4) The front face of the lense and the case are polycarbonate-based. Generally they are stable against water, alcohol, oil, salt and weak acids. However, avoid alkalis, aromatic hydrocarbons and halogenated hydrocarbons as those substances may expand or melt the lense and the case.
- 5) If placing filters (covers) in front of the sensor and perform detection through the filters, following may occur: detection of the filters (covers), changes of the detecting distance or unstable operations.
- 6) If sensors are in facing positions, light from the opposing sensor may cause mutual interferences and malfunction. Before use, check the installation conditions.
- 7) When arranging multiple sensors in parallel, keep the interval of neighboring sensors as below or over. Before use, ensure that there is no mutual interference.

Part No.	Sensor interval
AMBA1 series	5 cm 1.969 inch
AMA1 series	8 cm 3.150 inch
AMBA2 series	10 cm 3.937 inch
AMBA3 series	20 cm 7.874 inch

■ Recommended mounting direction

As below, install the sensor for the X and Z advancing directions of the targeted object.

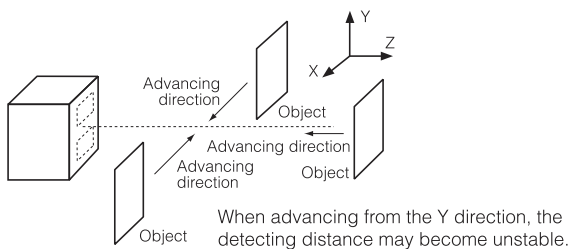

For general precautions, see "General precautions for motion sensors" in the next page.

■ Ambient operating conditions

- 1) Temperature: Refer to the absolute maximum ratings for the temperature of each individual sensor.
- 2) Humidity : 15 % to 85 % RH (No freezing nor condensation at low temperature)
- 3) Atmospheric pressure: 86 to 106 kPa
- 4) Because the humidity range differs depending on the ambient temperature, the humidity range indicated below should be used. Continuous operation of the switch is possible within this range, but continuous use near the limit of the range should be avoided. This humidity range does not guarantee permanent performance.

<MA Motion Sensor>

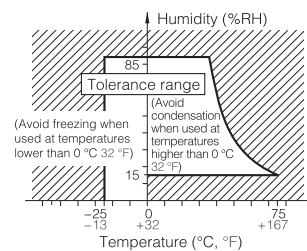

In general, degradation of electronic devices accelerates when they are operated under conditions of high temperature or high humidity. Before use, confirm the reliability of the sensors under the expected operating conditions.

- 5) The sensors do not have a water-proof or dust-proof construction. Depending on the ambient operating conditions, some means of providing protection from water and dust and preventing the formation of ice and condensation must be provided prior to using the sensors. If a sensor is used with a cover installed, the initial detection performance specifications may not be able to be met. Confirm the operation under the actual operating conditions.
- 6) Take care to avoid exposing the sensors to heat, vibration or impact since malfunctioning may result.

■ Concerning external surge voltages

Since the internal circuitry may be destroyed if an external surge voltages is supplied, provide an element which will absorb the surges.

■ Concerning power supplysuperimposed noise

- 1) Use a regulated power supply as the power supply. Otherwise, power supplysuperimposed noise may cause the sensors to malfunction.
- 2) To maintain the power supply noise performance, be certain to connect a capacitor (33 μ F or more) to the sensor power supply input terminal in order to stabilize the power supply voltage.

■ Drop damage

If the sensor is dropped, damage can occur resulting in incorrect operation. If dropped, be sure to do a visual check of the exterior for noticeable damage and check the operation characteristics for faulty operation.

■ Concerning the circuit sides

Since the circuit sides given in this catalog are not protected in terms of circuit design, check out the performance and reliability of the circuits prior to using the sensors.

Safety precautions

Head the following precautions to prevent injury or accidents.

- Do not use these sensors under any circumstances in which the range of their ratings, environment conditions or other specifications are exceeded. Using the sensors in any way which causes their specifications to be exceeded may generate abnormally high levels of heat, emit smoke, etc., resulting in damage to the circuitry and possibly causing an accident.
- Before connecting a connector, check the pin layout by referring to the connector wiring diagram, specifications diagram, etc., and make sure that the connector is connected properly. Take note that mistakes made in connection may cause unforeseen problems in operation, generate abnormally high levels of heat, emit smoke, etc., resulting in damage to the circuitry.
- Do not use any motion sensor which has been disassembled or remodeled.
- Protection circuit recommended The possible failure mode is either open or short of the output transistor. An excess heat is the cause for short mode failure. For any important and serious application in terms of safety, add protection circuit or any other protection method.