

RWC5050AK060-500

PHYSICAL DIMENSIONS:

A	50.00	±	0.50
B	44.00	±	1.50
C	20.50	±	0.50
D	17.00		MIN
E	10.00		REF
F	5.00	±	2.00
G	1.00	±	0.10
H	3.00		MAX
J	1.20		REF

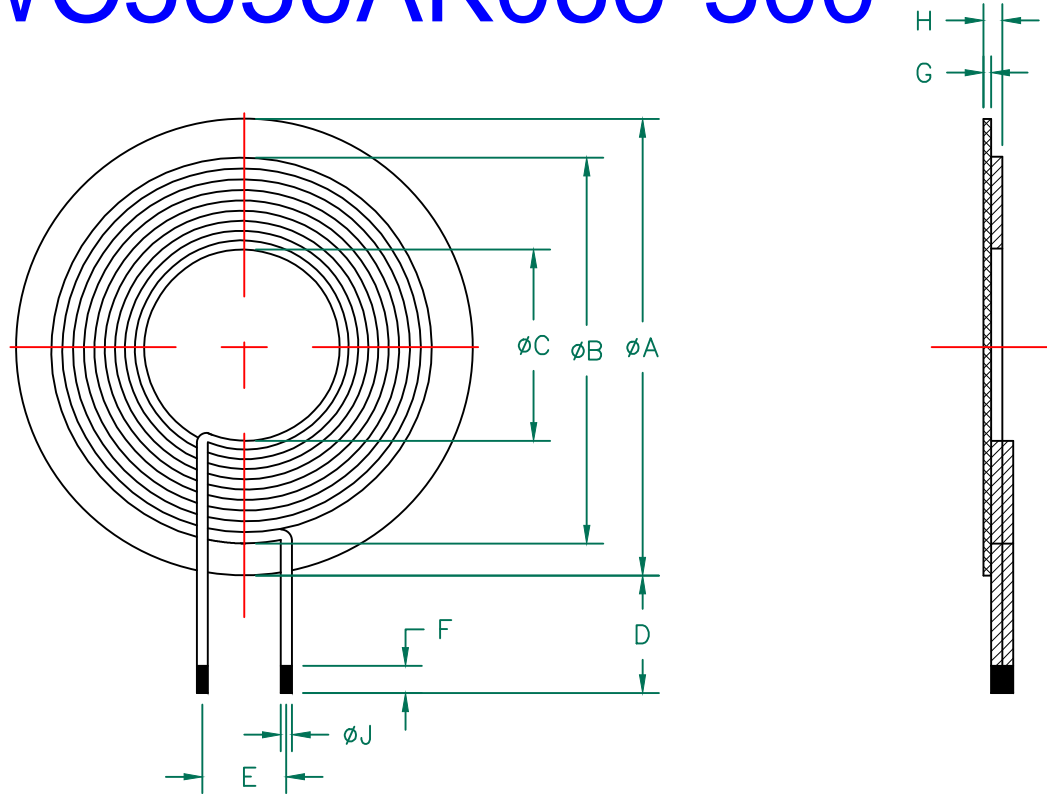

ELECTRICAL SPECIFICATION @ 25°C

	Min	Nom	Max
INDUCTANCE (uH)			
L @ 100KHz/1V ±10%	5.85	6.50	7.15
DCR (mΩ)			50
Q @ 100KHz/1V	70		

NOTES: UNLESS OTHERWISE SPECIFIED

1. OPERATING TEMPERATURE RANGE:
-40°C TO +125°C (INCLUDING SELF-HEATING).
2. STORAGE TEMPERATURE RANGE (PACKAGING CONDITIONS) :
-10°C TO +40°C AND RH 70% (MAX.)
3. FERRITE MATERIAL: LAIRD 28MAT.
4. COIL: ENAMELLED ROUND COPPER WIRES WITH SILK COVERING,
LITZ 0.08X105 STRANDS, 2UEW, 155°C 10Ts.
5. COIL AND FERRITE ARE GLUED BY EPOXY.



**UNCONTROLLED
DOCUMENT**

DIMENSIONS ARE IN mm.				This print is the property of Laird Tech. and is loaned in confidence subject to return upon request and with the understanding that no copies shall be made without the written consent of Laird Tech. All rights to design or invention are reserved.		Laird	
				PROJECT/PART NUMBER:	REV	PART TYPE:	DRAWN BY:
				RWC5050AK060-500	A		QIU
				DATE:	SCALE:	SHEET:	
				11/20/13	NTS	1 of 1	
A	ORIGINAL DRAFT	11/20/13	QIU	CAD #	TOOL #		
REV	DESCRIPTION	DATE	INT	RWC5050AK060-500-A	-		