



TCXO/VC-TCXO ULTRA MINIATURE SIZE LOW PROFILE HIGH STABILITY TG-5006CJ

NEWProduct Number (Please contact us)
X1G004131xxxx00

- Frequency range : 13 MHz to 52 MHz
- Supply voltage : 1.8 V / 2.8 V
- Frequency / temperature characteristics : $\pm 0.5 \times 10^{-6}$ Max. or $\pm 2.0 \times 10^{-6}$ Max.
- External dimensions: 2.0 x 1.6 x 0.73 mm
- Applications : GPS,
Wireless communication devices
(CDMA, WCDMA, LTE, WiMAX, other)
- Features : High stability
Low supply voltage (1.8 V)



Actual size

**Specifications (characteristics)**

Item	Symbol	Specifications		Conditions / Remarks
		VC-TCXO	TCXO	
Output frequency range	f _o	13.000 MHz to 52.000 MHz 16.367667 MHz, 16.368 MHz, 16.369 MHz, 19.2 MHz, 26 MHz and 38.4 MHz		Standard frequency
Supply voltage	V _{cc}	1.8 V \pm 0.1 V / 2.8 V \pm 0.14 V (Range :1.7 V to 3.3 V)		
Storage temperature	T _{stg}	-40 °C to +90 °C		Storage as single product.
Operating temperature	T _{use}	-30 °C to +85 °C		
Frequency tolerance	f _{tol}	$\pm 2.0 \times 10^{-6}$ Max.		After reflow, +25 °C
Frequency/temperature characteristics	fo-Tc	$\pm 0.5 \times 10^{-6}$ Max. / -30 °C to +85 °C		High stability version for GPS
		$\pm 2.0 \times 10^{-6}$ Max. / -30 °C to +85 °C		Standard stability version
		$\pm 2.0 \times 10^{-6}$ Max. / -40 °C to +85 °C (Option)		Customized product
Frequency/load coefficient	fo-Load	$\pm 0.2 \times 10^{-6}$ Max.		10 k Ω // 10 pF \pm 10 %
Frequency/voltage coefficient	fo-V _{cc}	$\pm 0.2 \times 10^{-6}$ Max.		V _{cc} =1.8 V \pm 0.1 V or 2.8 V \pm 0.14 V
Frequency aging	f _{age}	$\pm 1.0 \times 10^{-6}$ Max.		+25 °C, First year, 13 MHz \leq f _o \leq 40 MHz
		$\pm 1.5 \times 10^{-6}$ Max.		+25 °C, First year, 40 MHz < f _o \leq 52 MHz
Current consumption	I _{cc}	1.5 mA Max.		13 MHz \leq f _o \leq 26 MHz
		2.0 mA Max.		26 MHz < f _o \leq 52 MHz
Input resistance	R _{in}	500 k Ω Min.	—	V _c - GND (DC)
Frequency control range	f _{cont}	$\pm 8.0 \times 10^{-6}$ to $\pm 15.0 \times 10^{-6}$	—	V _c =0.9 V \pm 0.6 V (V _{cc} =1.8 V) or V _c =1.4 V \pm 1.0 V (V _{cc} =2.8 V)
Frequency change polarity	—	Positive polarity	—	
Symmetry	SYM	40 % to 60 %		GND level (DC cut)
Output voltage	V _{pp}	0.8 V Min.		Peak to Peak
Output load condition	Load _R	10 k Ω		DC cut capacitor = 0.01 μ F
	Load _C	10 pF		

* Note : Please contact us for requirements not listed in this specification.

External dimensions

(Unit:mm)

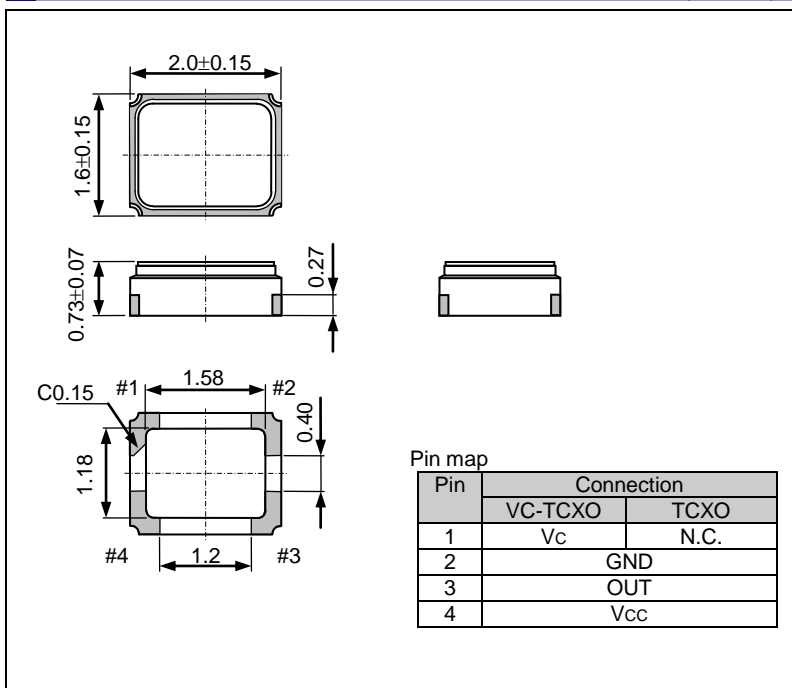
**Footprint (Recommended)**

(Unit:mm)

