

MCOT160128BY-RGBM	160 x 128	OLED Module
<b>Specification</b>		
Version: 1	Date: 10/12/2012	
<b>Revision</b>		
1	07/12/2012	First Issue

Display Features			Box Quantity	Weight / Display
Resolution	160 x 128			
Appearance	RGB on Black			
Logic Voltage	2.8V			
Interface	Multi			
Module Size	39.90 x 34.00 x 1.60mm			
Operating Temperature	-40°C ~ +80°C			
Construction	COT			

\* - For full design functionality, please use this specification in conjunction with the MDS535 specification. (Provided Separately)

Display Accessories	
Part Number	Description

Optional Variants	
Appearance	Voltage



# 1. Basic Specifications

## Display Specifications

- 1) Display Mode: Passive Matrix
- 2) Display Color: 262,144 Colors (Maximum)
- 3) Drive Duty: 1/128 Duty

## Mechanical Specifications

- 1) Outline Drawing: According to the annexed outline drawing
- 2) Number of Pixels: 160 (RGB) × 128
- 3) Panel Size: 39.90 × 34.00 × 1.60 (mm)
- 4) Active Area: 33.575 × 26.864 (mm)
- 5) Pixel Pitch: 0.07 × 0.21 (mm)
- 6) Pixel Size: 0.045 × 0.194 (mm)
- 7) Weight: 4.55 (g)

## Active Area / Memory Mapping & Pixel Construction

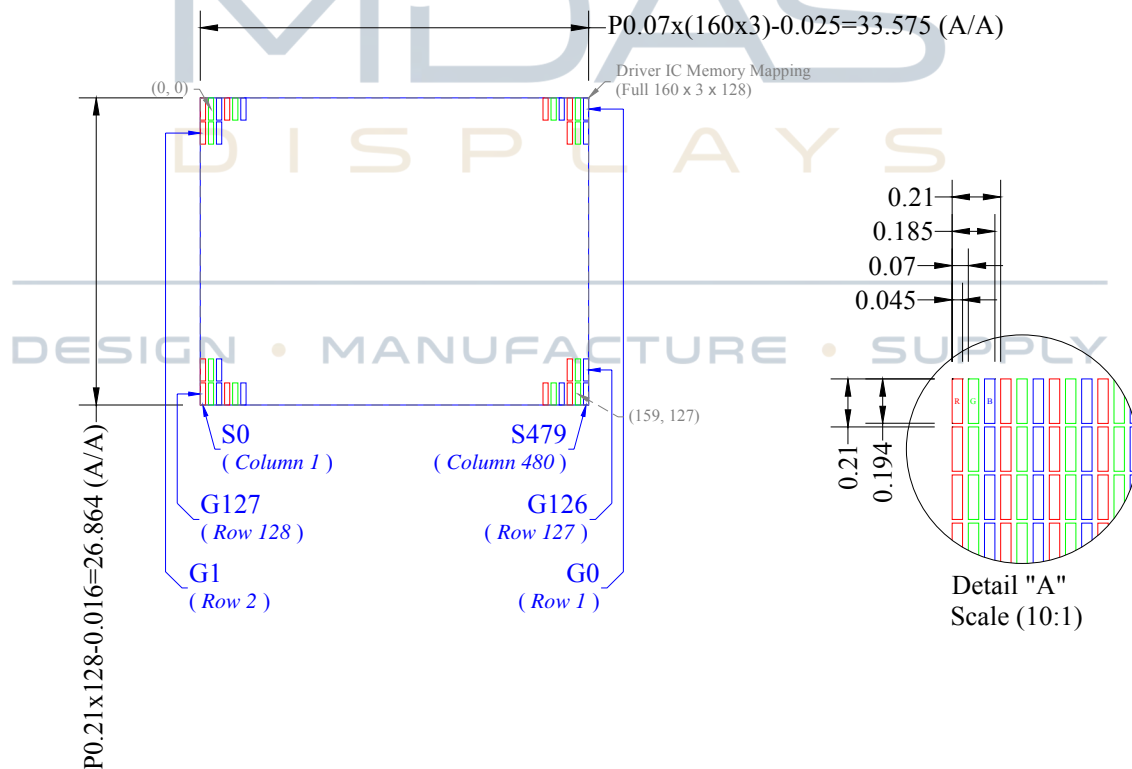

# Mechanical Drawing

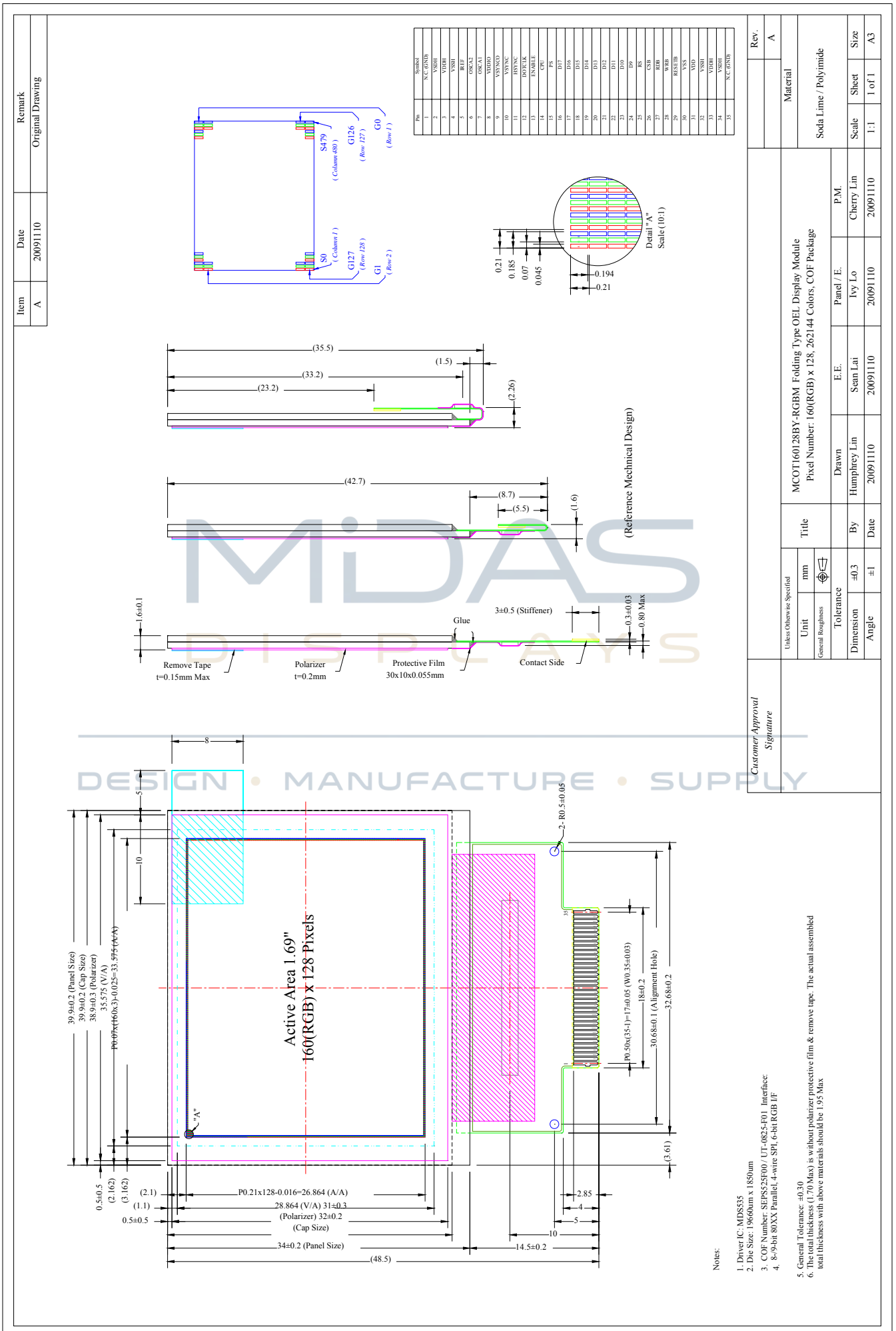

Item	A	Date	20091110	Remark	Original Drawing
Customer Approval Signature					
Unless Otherwise Specified		mm			
General Roughness		☉			
Tolerance		Panel / E.			
Dimension	±0.3	By	Humphrey Lin	Drawn	Senn Lai
Angle	±1	Date	20091110	E.E.	20091110
Title		MCO160128BY-RGBM Folding Type OLED Display Module Pixel Number: 160(RGB) x 128, 262144 Colors, COF Package			
Material		Soda Lime / Polyimide			
Scale	1:1	Sheet	1 of 1	Size	A3

- Notes:
- Driver IC: MDS535
  - Die Size: 1960um x 1850um
  - COF Number: SEPS25F00 / UT-0825-F01 Interface:
  - 8-9-bit 80XX Parallel, 4-wire SPI, 6-bit RGB IF
  - General Tolerance: ±0.30
  - The total thickness (1.70 Max) is without polarizer protective film & remove tape. The actual assembled total thickness with above materials should be 1.95 Max

## Pin Definition

Pin Number	Symbol	Type	Function
<b>Power Supply</b>			
31	VDD.	P	<b>Power Supply for Logic Circuit</b> This is a voltage supply pin. It must be connected to external source.
8	VDDIO	P	<b>Power Supply for Interface Logic Level</b> This is a voltage supply pin. It should be match with MCU interface voltage level. It must always be equal or lower than VDD.
30	VSS	P	<b>Ground of Logic Circuit</b> A reference for the logic pins. It must be connected to external ground.
3, 33	VDDH	P	<b>Power Supply for OEL Panel</b> This is the most positive voltage supply pin of the chip. It must be connected to external source.
2, 34 4, 32	VSDH VSSH	P	<b>Ground of OEL Panel</b> These are the ground pins for analog circuits. It must be connected to external ground. VSDH: Segment (Data Driver) VSSH: Common (Scan Driver)
<b>Driver</b>			
5	IREF	I/O	<b>Current Reference for Brightness Adjustment</b> This pin is segment (data) current reference pin. A 68kΩ resistor should be connected between this pin and VSS.
7 6	OSCA1 OSCA2	I O	<b>Fine Adjustment for Oscillation</b> The frequency is controlled by external 5.1kΩ resistor between OSCA1 and OSCA2. The oscillator signal is used for system clock generation. When the external clock mode is selected, OSCA1 is used external clock input.
<b>RGB Interface</b>			
9	VSYNCO	O	<b>Vertical Synchronization Triggering Signal</b>
10	VSYNC	I	<b>Vertical Synchronization Input Horizontal</b>
11	HSYNC	I	<b>Synchronization Input</b>
12	DOTCLK	I	<b>Dot Clock Input</b>
13	ENABLE	I	<b>Video Enable Input</b>
<b>MCU Interface</b>			
14	CPU	I	<b>Select the CPU Type</b> Low: 80XX-Series MCU High: 68XX-Series MCU.
15	PS	I	<b>Select Parallel/Serial Interface Type</b> Low: Serial Interface High: Parallel Interface
29	RESETB	I	<b>Power Reset for Controller and Driver</b> This pin is reset signal input. When the pin is low, initialization of the chip is executed.



## Pin Definition (Continued)

Pin Number	Symbol	Type	Function						
<i>MCU Interface (Continued)</i>									
26	CSB	I	<i>Chip Select</i> Low: MDS535 is selected and can be accessed. High: MDS535 is not selected and cannot be accessed.						
25	RS	I	<i>Data/Command Control</i> Low: Command High: Parameter/Data						
27	RDB	I	<i>Read or Read/Write Enable</i> 68XX Parallel Interface: Bus Enabled Strobe (Active High) 80XX Parallel Interface: Read Strobe Signal (Active Low) While using SPI, it must be connected to VDD or VSS.						
28	WRB	I	<i>Write or Read/Write Select</i> 68XX Parallel Interface: Read (Low)/Write (High) Select 80XX Parallel Interface: Write Strobe Signal (Active Low) While using SPI, it must be connected to VDD or VSS.						
16~24	D17~D9	I/O	<i>Host Data Input/Output Bus</i> These pins are 9-bit bi-directional data bus to be connected to the microprocessor's data bus.						
			<table border="1"> <thead> <tr> <th>PS</th> <th>Description</th> </tr> </thead> <tbody> <tr> <td>0</td> <td>D[17]/SCL: Synchronous Clock Input D[16]/SDI: Serial Data Input D[15]/SDO: Serial Data Output</td> </tr> <tr> <td>1</td> <td>9-bit Bus: D[17:9] 8-bit Bus: D[17:10]</td> </tr> </tbody> </table>	PS	Description	0	D[17]/SCL: Synchronous Clock Input D[16]/SDI: Serial Data Input D[15]/SDO: Serial Data Output	1	9-bit Bus: D[17:9] 8-bit Bus: D[17:10]
			PS	Description					
0	D[17]/SCL: Synchronous Clock Input D[16]/SDI: Serial Data Input D[15]/SDO: Serial Data Output								
1	9-bit Bus: D[17:9] 8-bit Bus: D[17:10]								
While using SPI, the unused pins must be connected to VSS.									
<i>Reserve</i>									
1, 35	N.C. (GND)	-	<i>Reserved Pin (Supporting Pin)</i> The supporting pins can reduce the influences from stresses on the function pins. These pins must be connected to external ground.						



## Block Diagram

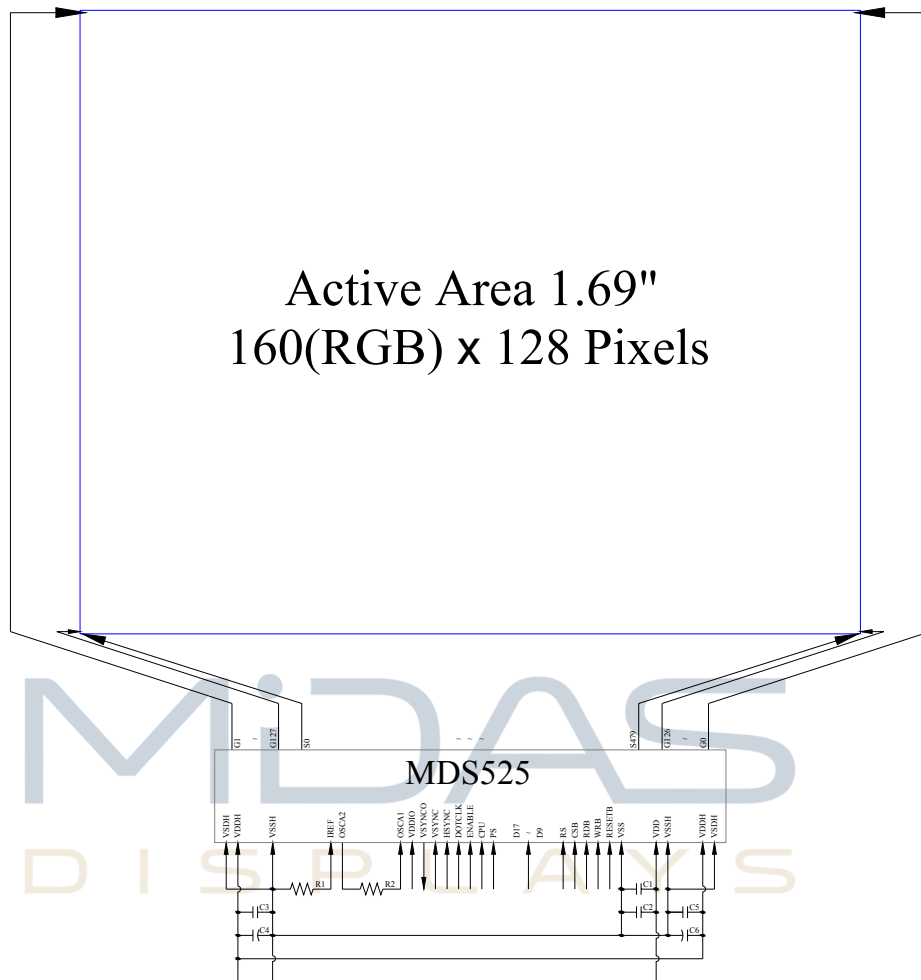

MCU Interface Selection: CPU, PS

Pins connected to MCU interface: D17~D9, RS, CSB, RDB, WRB, and RESETB

Pins connected to RGB interface: D17~D12, VSYNC, HSYNC, DOTCLK, and ENABLE

C1, C3, C5: 0.1 $\mu$ F

C2: 4.7 $\mu$ F

C4, C6: 4.7 $\mu$ F / 25V Tantalum Capacitor

R1: 68k $\Omega$

R2: 5.1k $\Omega$

## Absolute Maximum Ratings

Parameter	Symbol	Min	Max	Unit	Notes
Supply Voltage for Logic	V <sub>DD</sub>	-0.3	4	V	1, 2
Supply Voltage for I/O Pins	V <sub>DDIO</sub>	-0.3	4	V	1, 2
Supply Voltage for Display	V <sub>DDH</sub>	-0.3	16	V	1, 2
Operating Temperature	T <sub>OP</sub>	-40	70	°C	-
Storage Temperature	T <sub>STG</sub>	-40	80	°C	-

Life Time 50cd/m<sup>2</sup>, 30,000 hours (TYP) Note3.

Note 1: All the above voltages are on the basis of “VSS = 0V”.

Note 2: When this module is used beyond the above absolute maximum ratings, permanent breakage of the module may occur. Also, for normal operations, it is desirable to use this module under the conditions according to Section 3. “Optics & Electrical Characteristics”. If this module is used beyond these conditions, malfunctioning of the module can occur and the reliability of the module may deteriorate.

Note 3: V<sub>CC</sub> = 14V, T<sub>a</sub> = 25°C, 50% Checkerboard.

Software configuration follows Section 4.4 Initialization.

End of lifetime is specified as 50% of initial brightness reached. The average operating lifetime at room temperature is estimated by the accelerated operation at high temperature conditions.

---

DESIGN • MANUFACTURE • SUPPLY

## Optics & Electrical Characteristics

### Optics Characteristics

Characteristics	Symbol	Conditions	Min	Typ	Max	Unit
Brightness (White)	$L_{br}$	Note 4	60	75	-	cd/m <sup>2</sup>
C.I.E. (White)	(x)	C.I.E. 1931	0.26	0.30	0.34	
	(y)		0.29	0.33	0.37	
C.I.E. (Red)	(x)	C.I.E. 1931	0.60	0.64	0.68	
	(y)		0.30	0.34	0.38	
C.I.E. (Green)	(x)	C.I.E. 1931	0.27	0.31	0.35	
	(y)		0.58	0.62	0.66	
C.I.E. (Blue)	(x)	C.I.E. 1931	0.10	0.14	0.18	
	(y)		0.12	0.16	0.20	
Dark Room Contrast	CR		-	>2000:1	-	
View Angle			>160		-	degree

\* Optical measurement taken at  $V_{DD} = 2.8V$ ,  $V_{DDH} = 14V$ .  
Software configuration follows Section 4.4 Initialization.

### DC Characteristics

Characteristics	Symbol	Conditions	Min	Typ	Max	Unit
Supply Voltage for Logic	$V_{DD}$		2.6	2.8	3.3	V
Supply Voltage for I/O Pins	$V_{DDIO}$		1.6	2.8	3.3	V
Supply Voltage for Display	$V_{DDH}$	Note 4	13.5	14	14.5	V
High Level Input	$V_{IH}$		$0.8 \times V_{DD}$	-	$V_{DD}$	V
Low Level Input	$V_{IL}$		0	-	0.4	V
High Level Output	$V_{OH1}$	$I_{OH} = -0.4mA$	$V_{DD}-0.4$	-		V
	$V_{OH2}$	$I_{OH} = -0.4mA$				
Low Level Output Operating	$V_{OL1}$	$I_{OL} = -0.1mA$		-	0.4	V
	$V_{OL2}$	$I_{OL} = -0.1mA$				
Current for $V_{DD}$ Operating	$I_{DD}$		-	2.5	3.5	mA
Current for $V_{DDH}$	$I_{DDH}$	Note 5	-	14.9	18.6	mA
		Note 6	-	26.2	32.8	mA

Note 4: Brightness ( $L_{br}$ ) and Supply Voltage for Display ( $V_{DDH}$ ) are subject to the change of the panel characteristics and the customer's request.

Note 5:  $V_{DD} = 2.8V$ ,  $V_{DDH} = 14V$ , 50% Display Area Turn on.

Note 6:  $V_{DD} = 2.8V$ ,  $V_{DDH} = 14V$ , 100% Display Area Turn on.

\* Software configuration follows Section 4.4 Initialization.



## AC Characteristics

### 68XX-Series MPU Parallel Interface Timing Characteristics:

( $V_{DD} = 2.8V$ ,  $T_a = 25^\circ C$ )

Symbol	Description	Min	Max	Unit	Port	
$t_{AH6}$	Address Setup Timing	(Read)	10	-	ns	CSB RS
		(Write)	5	-	ns	
$t_{AS6}$	Address Hold Timing	(Read)	10	-	ns	
		(Write)	5	-	ns	
$t_{CYC6}$	System Cycle Timing Read	200	-	ns	E	
$t_{ELR6}$	"L" Pulse Width Read "H"	90	-	ns		
$t_{EHR6}$	Pulse Width System Cycle	90	-	ns		
$t_{CYC6}$	Timing Write "L" Pulse	100	-	ns		
$t_{ELW6}$	Width Write "H" Pulse Width	45	-	ns		
$t_{EHW6}$	Read Data Output Delay Time	45	-	ns		
$t_{RDD6}$	Data Hold Timing Data Setup * $CL = 15pF$	0	70	ns	D[17:9]	
$t_{RDH6}$	Timing Data Hold Timing	0	70	ns		
$t_{DS6}$		40	-	ns		
$t_{DH6}$		10	-	ns		

\* All the timing reference is 10% and 90% of  $V_{DD}$ .

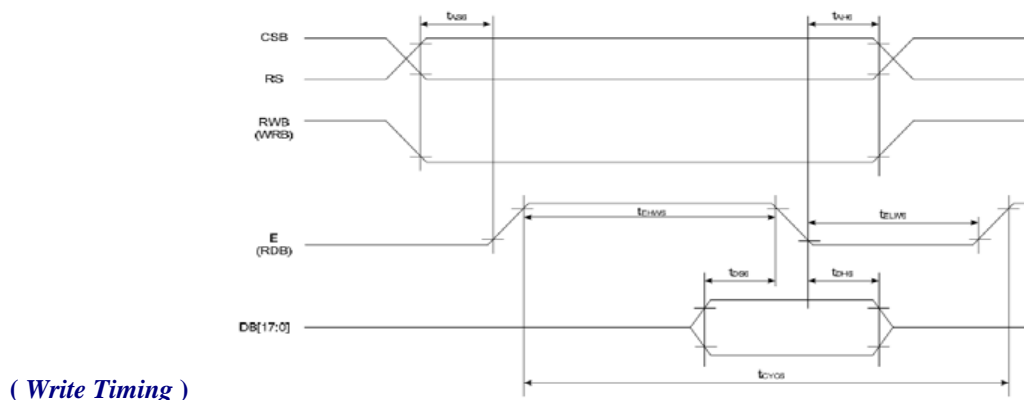
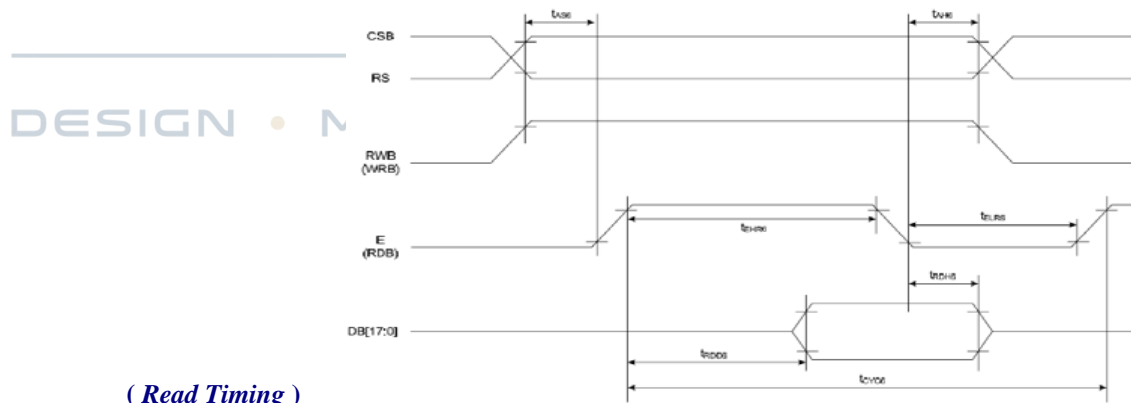

80XX-Series MPU Parallel Interface Timing Characteristics:

( $V_{DD} = 2.8V, T_a = 25^\circ C$ )

Symbol	Description	Min	Max	Unit	Port
$t_{AS8}$	Address Setup Timing Address	5	-	ns	CSB
$t_{AH8}$	Hold Timing System Cycle	5	-	ns	RS
$t_{CYC8}$	Timing Read "L" Pulse Width	200	-	ns	RDB
$t_{RDLR8}$	Read "H" Pulse Width System	90	-	ns	
$t_{RDHR8}$	Cycle Timing Write "L" Pulse	90	-	ns	
$t_{CYC8}$	Width Write "H" Pulse Width	100	-	ns	WRB
$t_{WRLW8}$	Read Data Output Delay Time Data	45	-	ns	
$t_{WRHW8}$	Hold Timing Data Setup	45	-	ns	D[17:9]
$t_{RDD8}$	Timing Data Hold Timing	-	60	ns	
$t_{RDH8}$		0	60	ns	
$t_{DS8}$		30	-	ns	
$t_{DH8}$		10	-	ns	

\* All the timing reference is 10% and 90% of  $V_{DD}$ .

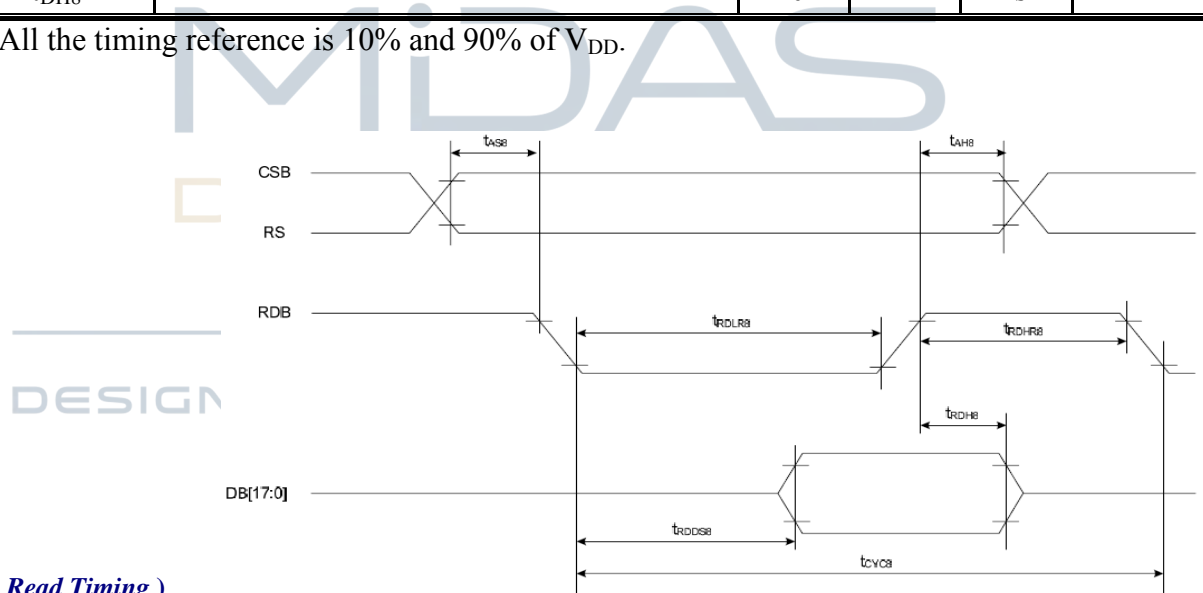

( Read Timing )

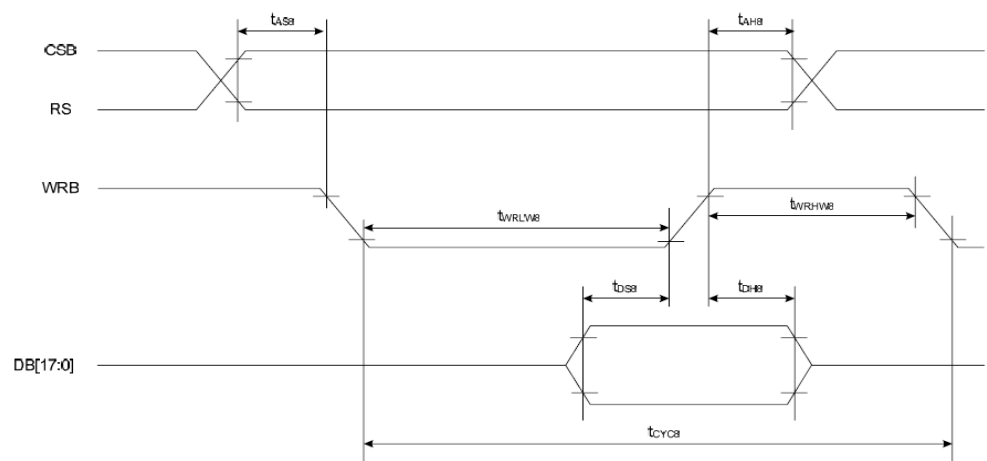

( Write Timing )





# MiDAS

DISPLAYS

---

DESIGN • MANUFACTURE • SUPPLY



## Functional Specification

### Commands

Refer to the Technical Manual for the MDS535

### Power down and Power up Sequence

To protect OEL panel and extend the panel life time, the driver IC power up/down routine should include a delay period between high voltage and low voltage power sources during turn on/off. It gives the OEL panel enough time to complete the action of charge and discharge before/after the operation.

#### Power up Sequence:

1. Power up  $V_{DD} / V_{DDIO}$
2. Send Display off command
3. Initialization
4. Clear Screen
5. Power up  $V_{DDH}$
6. Delay 100ms  
(when  $V_{DDH}$  is stable)
7. Send Display on command

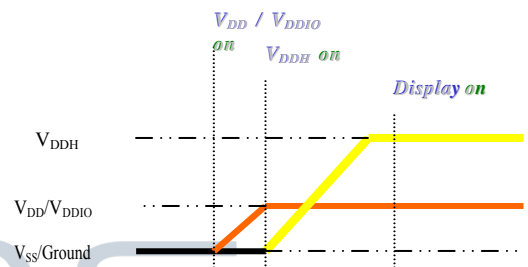

#### Power down Sequence:

1. Send Display off command
2. Power down  $V_{DDH}$
3. Delay 100ms  
(when  $V_{DDH}$  is reach 0 and panel is completely discharges)
4. Power down  $V_{DD} / V_{DDIO}$

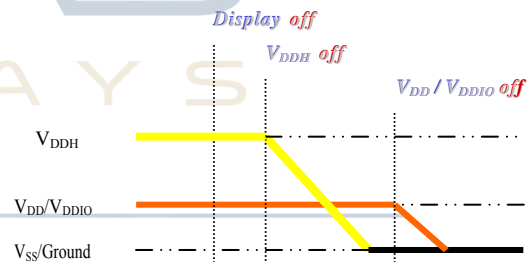

### Reset Circuit

When RESETB input is low, the chip is initialized with the following status:

1. Frame Frequency: 90Hz
2. Oscillation: Internal Oscillator On
3. DDRAM Write Horizontal Address: MX1 = 0x00, MX2 = 0x9F
4. DDRAM Write Vertical Address: MY1 = 0x00, MY2 = 0x7F
5. Display Data RAM Write: HC = 1, VC = 1, HV = 0
6. RGB Data Swap: Off
7. Row Scan Shift Direction: G0, G1, ..., G126, G127
8. Column Data Shift Direction: S0, S1, ..., S478, S479
9. Display On/Off: Off
10. Panel Display Size: FX1 = 0x00, FX2 = 0x9F, FY1 = 0x00, FY1 = 0x7F
11. Display Data RAM Read Column/Row Address: FAC = 0x00, FAR = 0x00
12. Precharge Time (R/G/B): 0 Clock
13. Precharge Current (R/G/B): 0 $\mu$ A
14. Driving Current (R/G/B): 0 $\mu$ A



## Actual Application Example

Command usage and explanation of an actual example

<Initialization>

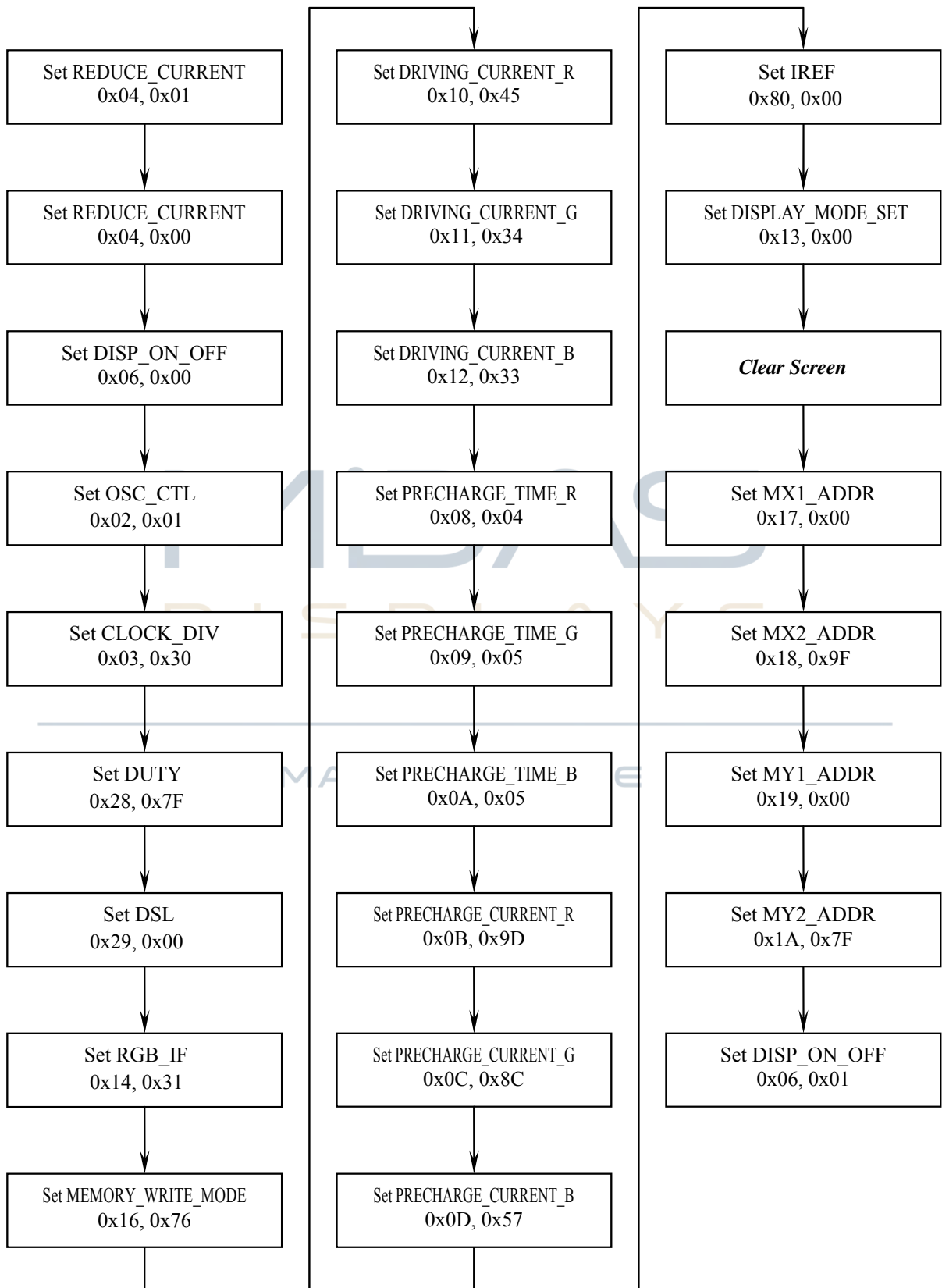

If the noise is accidentally occurred at the displaying window during the operation, please reset the display in order to recover the display function.



## Reliability

### Contents of Reliability Tests

Item	Conditions	Criteria
High Temperature Operation	70°C, 240 hrs	The operational functions work.
Low Temperature Operation	-40°C, 240 hrs	
High Temperature Storage	80°C, 240 hrs	
Low Temperature Storage	-40°C, 240 hrs	
High Temperature/Humidity Operation	60°C, 90% RH, 120 hrs	
Thermal Shock	-40°C ⇔ 85°C, 24 cycles 60 mins dwell	

- \* The samples used for the above tests do not include polarizer.
- \* No moisture condensation is observed during tests.

### Failure Check Standard

After the completion of the described reliability test, the samples were left at room temperature for 2 hrs prior to conducting the failure test at 23±5°C; 55±15% RH.

MIDAS  
DISPLAYS

---

DESIGN • MANUFACTURE • SUPPLY



## Outgoing Quality Control Specifications

### Environment Required

Customer's test & measurement are required to be conducted under the following conditions:

Temperature:	$23 \pm 5^{\circ}\text{C}$
Humidity:	$55 \pm 15\% \text{RH}$
Fluorescent Lamp:	30W
Distance between the Panel & Lamp:	$\geq 50 \text{ cm}$
Distance between the Panel & Eyes of the Inspector: Finger glove (or finger cover) must be worn by the inspector. Inspection table or jig must be anti-electrostatic.	$\geq 30 \text{ cm}$

### Sampling Plan

Level II, Normal Inspection, Single Sampling, MIL-STD-105E



### Criteria & Acceptable Quality Level

Partition	AQL	Definition
Major	0.65	Defects in Pattern Check (Display On)
Minor	1.0	Defects in Cosmetic Check (Display Off)

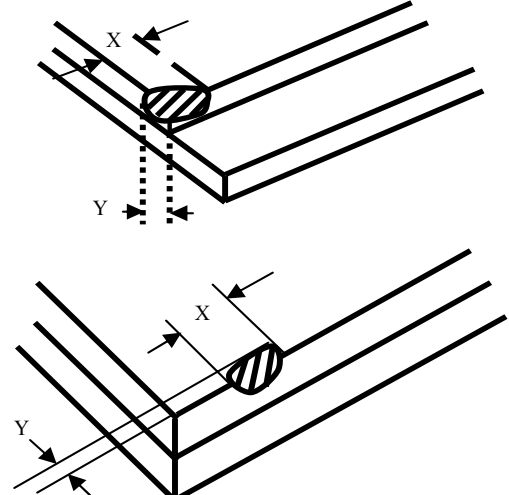
Cosmetic Check (Display Off) in Non-Active Area

Check Item	Classification	Criteria
Panel General Chipping	Minor	<p><math>X &gt; 6 \text{ mm}</math> (Along with Edge)  <math>Y &gt; 1 \text{ mm}</math> (Perpendicular to edge)</p> 

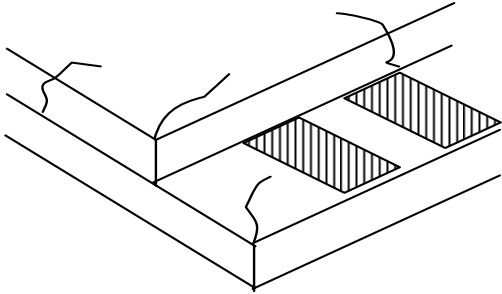
Cosmetic Check (Display Off) in Non-Active Area (Continued)

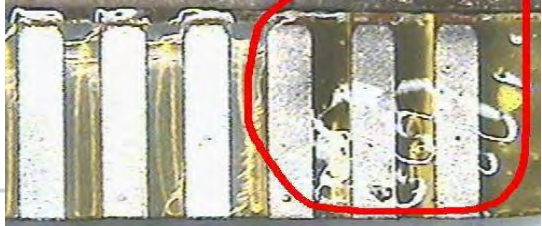
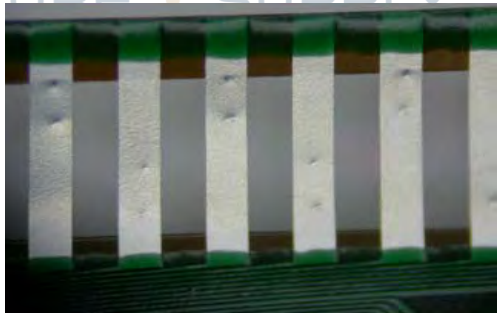
Check Item	Classification	Criteria
Panel Crack	Minor	<p>Any crack is not allowable.</p>  <p>A 3D perspective diagram of a rectangular panel with a crack running along one of its edges. The crack is shown as a jagged line extending from the top surface down to the bottom surface.</p>
Copper Exposed (Even Pin or Film)	Minor	<p>Not Allowable by Naked Eye Inspection</p>
Film or Trace Damage	Minor	 <p>A close-up photograph of a yellow conductive film with a circular hole or damage. A green component is visible in the background.</p>
Glue or Contamination on Pin (Couldn't Be Removed by Alcohol)	Minor	 <p>A microscopic view of several vertical pins. One pin is circled in red, showing a white, irregular substance (glue or contamination) on its surface.</p>
Terminal Lead Prober Mark	Acceptable	 <p>A microscopic view of several vertical terminal leads. The leads are white and have a green band at the top. There are some small marks on the leads.</p>
Ink Marking on Back Side of panel (Exclude on Film)	Acceptable	<p>Ignore for Any</p>



Cosmetic Check (Display Off) in Active Area

It is recommended to execute in clear room environment (class 10k) if actual in necessary.

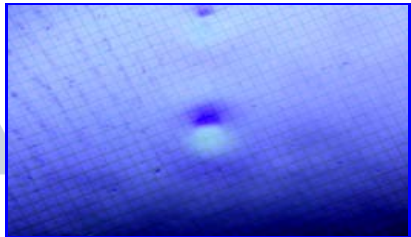
Check Item	Classification	Criteria
Any Dirt & Scratch on Polarizer's Protective Film Scratches, Fiber,	Acceptable	Ignore for not Affect the Polarizer
Line-Shape Defect (On Polarizer)	Minor	$W \leq 0.1$ Ignore $W > 0.1, L \leq 2 L$ $n \leq 1$ $> 2$ $n = 0$
Dirt, Black Spot, Foreign Material, (On Polarizer)	Minor	$\Phi \leq 0.1$ Ignore $0.1 < \Phi \leq 0.25$ $n \leq 1$ $0.25 < \Phi$ $n = 0$
Dent, Bubbles, White spot (Any Transparent Spot on Polarizer)	Minor	$\Phi \leq 0.5$ → Ignore if no Influence on Display $0.5 < \Phi$ $n = 0$ 
Fingerprint, Flow Mark (On Polarizer)	Minor	Not Allowable

\* Protective film should not be tear off when cosmetic check.

\*\* Definition of W & L &  $\Phi$  (Unit: mm):  $\Phi = (a + b) / 2$

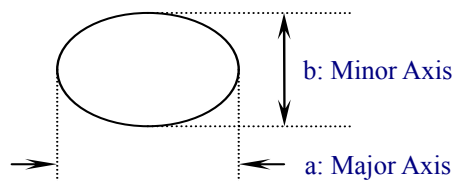
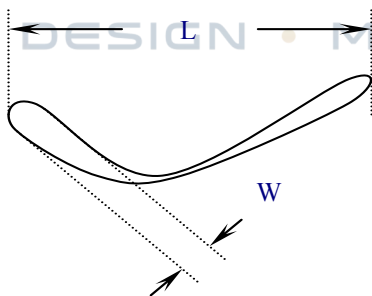

Pattern Check (Display On) in Active Area

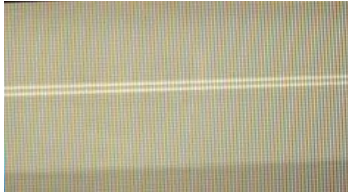
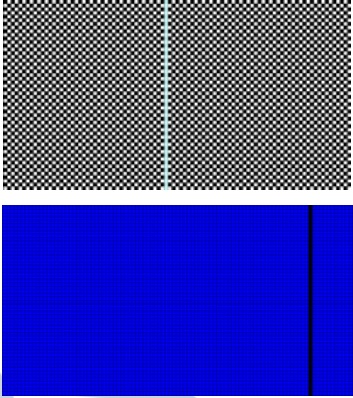
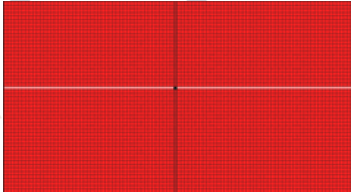
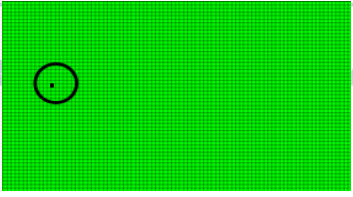
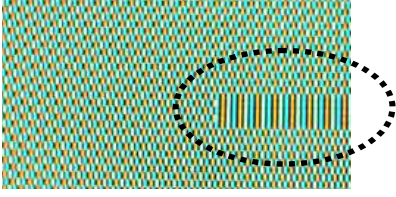
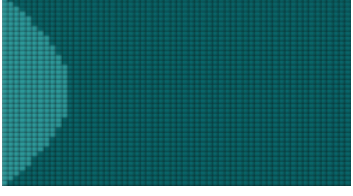
Check Item	Classification	Criteria
No Display	Major	Not allowable
Bright Line	Major	
Missed Line	Major	
Pixel Short	Major	
Darker Pixel	Major	
Wrong Display	Major	
Un-Uniform (Luminance Variation within a Display)	Major	



# MiDAS

DISPLAYS

---

DESIGN • MANUFACTURE • SUPPLY



## 8. Precautions When Using These OEL Display Modules

### Handling Precautions

- 1) Since the display panel is being made of glass, do not apply mechanical impacts such as dropping from a high position.
- 2) If the display panel is broken by some accident and the internal organic substance leaks out, be careful not to inhale nor lick the organic substance.
- 3) If pressure is applied to the display surface or its neighborhood of the OEL display module, the cell structure may be damaged and be careful not to apply pressure to these sections.
- 4) The polarizer covering the surface of the OEL display module is soft and easily scratched. Please be careful when handling the OEL display module.
- 5) When the surface of the polarizer of the OEL display module has soil, clean the surface. It takes advantage of by using following adhesion tape.
  - \* Scotch Mending Tape No. 810 or an equivalentNever try to breathe upon the soiled surface nor wipe the surface using cloth containing solvent such as ethyl alcohol, since the surface of the polarizer will become cloudy.  
Also, pay attention that the following liquid and solvent may spoil the polarizer:
  - \* Water
  - \* Ketone
  - \* Aromatic Solvents
- 6) Hold the OEL display module very carefully when placing the OEL display module onto/into any device. Do not apply excessive stress or pressure to the OEL module. And, do not over bend the film with electrode layouts. These stresses will influence the display performance. Also, secure sufficient rigidity for the outer cases.

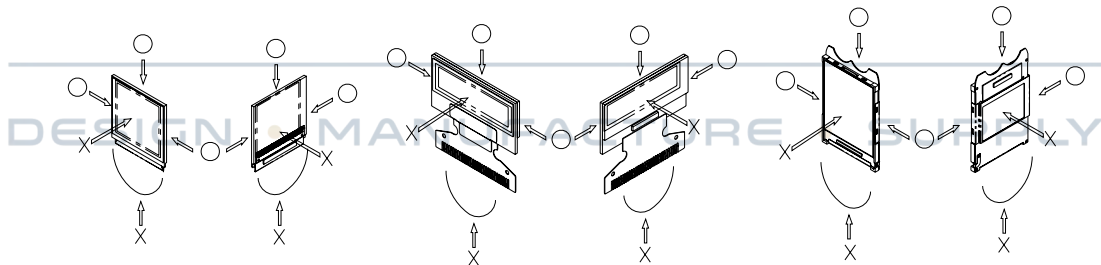

- 7) Do not apply stress to the LSI chips and the surrounding molded sections.
- 8) Do not disassemble nor modify the OEL display module.
- 9) Do not apply input signals while the logic power is off.
- 10) Pay sufficient attention to the working environments when handing OEL display modules to prevent occurrence of element breakage accidents by static electricity.
  - \* Be sure to make human body grounding when handling OEL display modules.
  - \* Be sure to ground tools to use or assembly such as soldering irons.
  - \* To suppress generation of static electricity, avoid carrying out assembly work under dry environments.
  - \* Protective film is being applied to the surface of the display panel of the OEL display module. Be careful since static electricity may be generated when exfoliating the protective film.
- 11) Protection film is being applied to the surface of the display panel and removes



the protection film before assembling it. At this time, if the OEL display module has been stored for a long period of time, residue adhesive material of the protection film may remain on the surface of the display panel after removed of the film. In such case, remove the residue material by the method introduced in the above Section 5).

- 12) If electric current is applied when the OEL display module is being dewed or when it is placed under high humidity environments, the electrodes may be corroded and be careful to avoid the above.

### Storage Precautions

- 1) When storing OEL display modules, put them in static electricity preventive bags avoiding exposure to direct sun light nor to lights of fluorescent lamps, etc. and, also, avoiding high temperature and high humidity environments or low temperature (less than 0°C) environments. We recommend you to store these modules in the packaged state when they were shipped from Midas Displays. At that time, be careful not to let water drops adhere to the packages or bags nor let dewing occur with them.
- 2) If electric current is applied when water drops are adhering to the surface of the OEL display module, when the OEL display module is being dewed or when it is placed under high humidity environments, the electrodes may be corroded and be careful about the above.

### Designing Precautions

- 1) The absolute maximum ratings are the ratings which cannot be exceeded for OEL display module, and if these values are exceeded, panel damage may be happen.
- 2) To prevent occurrence of malfunctioning by noise, pay attention to satisfy the VIL and VIH specifications and, at the same time, to make the signal line cable as short as possible.
- 3) We recommend you to install excess current preventive unit (fuses, etc.) to the power circuit (VDD). (Recommend value: 0.5A)
- 4) Pay sufficient attention to avoid occurrence of mutual noise interference with the neighboring devices.
- 5) As for EMI, take necessary measures on the equipment side basically.
- 6) When fastening the OEL display module, fasten the external plastic housing section.
- 7) If power supply to the OEL display module is forcibly shut down by such errors as taking out the main battery while the OEL display panel is in operation, we cannot guarantee the quality of this OEL display module.
- 8) The electric potential to be connected to the rear face of the IC chip should be as follows: MDS535  
\* Connection (contact) to any other potential than the above may lead to rupture of the IC.



## Precautions when disposing of the OEL display modules

- 1) Request the qualified companies to handle industrial wastes when disposing of the OEL display modules. Or, when burning them, be sure to observe the environmental and hygienic laws and regulations.

## Other Precautions

- 1) When an OEL display module is operated for a long of time with fixed pattern may remain as an after image or slight contrast deviation may occur. Nonetheless, if the operation is interrupted and left unused for a while, normal state can be restored. Also, there will be no problem in the reliability of the module.
- 2) To protect OEL display modules from performance drops by static electricity rapture, etc., do not touch the following sections whenever possible while handling the OEL display modules.
  - \* Pins and electrodes
  - \* Pattern layouts such as the COF
- 3) With this OEL display module, the OEL driver is being exposed. Generally speaking, semiconductor elements change their characteristics when light is radiated according to the principle of the solar battery. Consequently, if this OEL driver is exposed to light, malfunctioning may occur.
  - \* Design the product and installation method so that the OEL driver may be shielded from light in actual usage.
  - \* Design the product and installation method so that the OEL driver may be shielded from light during the inspection processes.
- 4) Although this OEL display module stores the operation state data by the commands and the indication data, when excessive external noise, etc. enters into the module, the internal status may be changed. It therefore is necessary to take appropriate measures to suppress noise generation or to protect from influences of noise on the system design.
- 5) We recommend you to construct its software to make periodical refreshment of the operation statuses (re-setting of the commands and re-transference of the display data) to cope with catastrophic noise.

