



## Features

- Available in E12 series
- Unit height of 3 mm
- Current up to 3 A
- RoHS compliant\*

## Applications

- Input/output of DC/DC converters
- Power supplies for:
  - Portable communication equipment
  - Camcorders
  - LCD TVs
  - Car radios

# SRR6603 Series - Shielded Power Inductors

## Electrical Specifications

Bourns Part No.	Inductance 100 KHz		Q Ref.	Test Frequency (KHz) Q	SRF Nom. (MHz)	RDC Max. ( $\Omega$ )	I rms (A)	I sat (A)
	uH	Tol. %						
SRR6603-1R0ML	1.0	$\pm 20$	30	200	250	0.040	3.00	1.4
SRR6603-1R5ML	1.5	$\pm 20$	30	200	125	0.045	2.80	0.93
SRR6603-2R2ML	2.2	$\pm 20$	40	200	120	0.050	1.80	0.92
SRR6603-3R3ML	3.3	$\pm 20$	40	200	120	0.055	1.60	0.75
SRR6603-4R7ML	4.7	$\pm 20$	40	200	105	0.060	1.40	0.58
SRR6603-6R8ML	6.8	$\pm 20$	40	200	50	0.065	1.20	0.58
SRR6603-100ML	10.0	$\pm 20$	40	200	38	0.075	1.00	0.37
SRR6603-150ML	15.0	$\pm 20$	40	100	33	0.090	0.80	0.31
SRR6603-220ML	22.0	$\pm 20$	40	100	25	0.110	0.70	0.30
SRR6603-330ML	33.0	$\pm 20$	40	100	20	0.190	0.60	0.24
SRR6603-470ML	47.0	$\pm 20$	40	100	20	0.230	0.50	0.24
SRR6603-680ML	68.0	$\pm 20$	40	100	15	0.290	0.40	0.17
SRR6603-101ML	100.0	$\pm 20$	40	100	10	0.480	0.30	0.13
SRR6603-151ML	150.0	$\pm 20$	40	100	9	0.590	0.26	0.10
SRR6603-221ML	220.0	$\pm 20$	40	100	6	0.770	0.22	0.10
SRR6603-331ML	330.0	$\pm 20$	40	100	5	1.400	0.20	0.07
SRR6603-471ML	470.0	$\pm 20$	40	100	4	1.800	0.19	0.06
SRR6603-681ML	680.0	$\pm 20$	40	100	3	2.200	0.18	0.055
SRR6603-102ML	1000.0	$\pm 20$	40	100	2	3.400	0.15	0.045
SRR6603-152ML	1500.0	$\pm 20$	50	100	2	4.200	0.12	0.035
SRR6603-222ML	2200.0	$\pm 20$	50	100	2	8.500	0.10	0.028
SRR6603-332ML	3300.0	$\pm 20$	50	100	1	11.00	00.08	0.024
SRR6603-472ML	4700.0	$\pm 20$	50	100	1	13.90	00.06	0.021
SRR6603-682ML	6800.0	$\pm 20$	50	100	1	25.00	00.04	0.019
SRR6603-103ML	10000.0	$\pm 20$	50	100	0.8	32.80	00.02	0.017

## Schematic

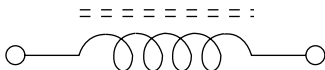

## Recommended Layout

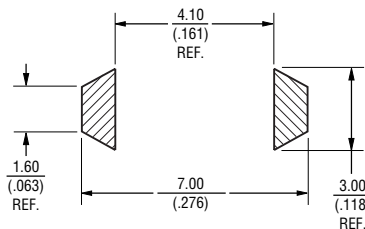

## General Specifications

Test Voltage ..... 0.1 V  
 Reflow Soldering .. 250 °C, 10 sec. max.  
 (In compliance with JEDEC, J-STD-020C, Table 4-2)  
 Operating Temperature  
 ..... -55 °C to +125 °C  
 (Temperature rise included)  
 Storage Temperature  
 ..... -55 °C to +125 °C  
 Resistance to Soldering Heat  
 ..... 250 °C, 10 sec. max.  
 Moisture Sensitivity Level ..... 1  
 ESD Classification (HBM)..... N/A

## Materials

Core ..... Ferrite DR & RI  
 Wire ..... Enameled copper  
 Base ..... Ceramic  
 Terminal ..... Ag/Ni/Au  
 Rated Current  
 ..... Ind. drop of 30 % typ. at Isat  
 Temperature Rise  
 ..... 30 °C max. at rated I rms  
 Packaging ..... 600 pcs. per reel

## Product Dimensions

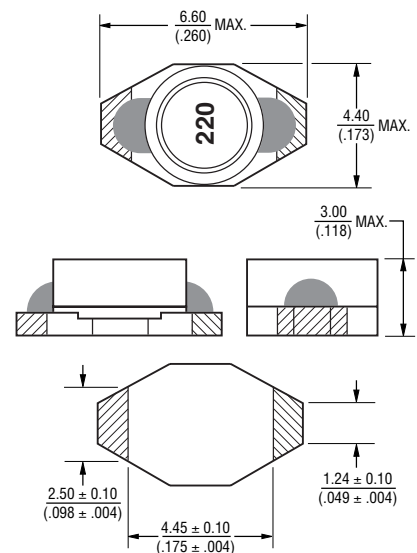

DIMENSIONS:  $\frac{\text{MM}}{\text{(INCHES)}}$

\*RoHS Directive 2002/95/EC Jan. 27, 2003 including annex and RoHS Recast 2011/65/EU June 8, 2011.

Specifications are subject to change without notice.

The device characteristics and parameters in this data sheet can and do vary in different applications and actual device performance may vary over time.

Users should verify actual device performance in their specific applications.

# SRR6603 Series - Shielded Power Inductors

**BOURNS®**

## Soldering Profile

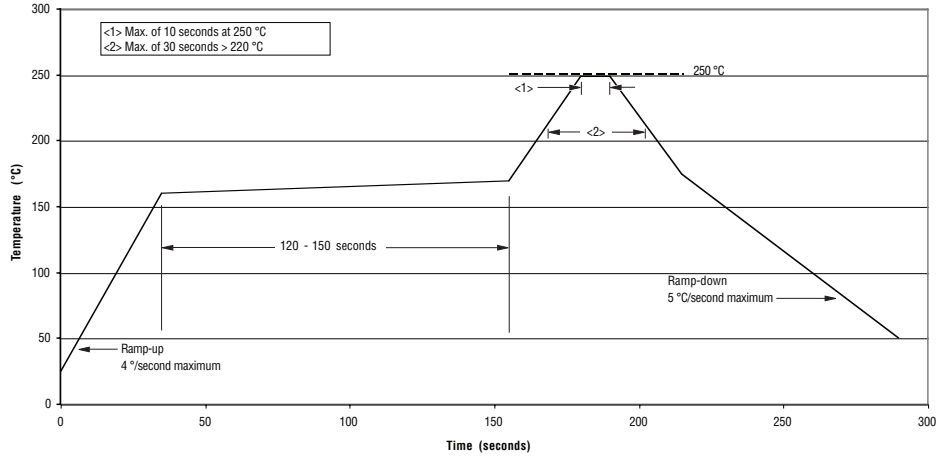

## Packaging Specifications

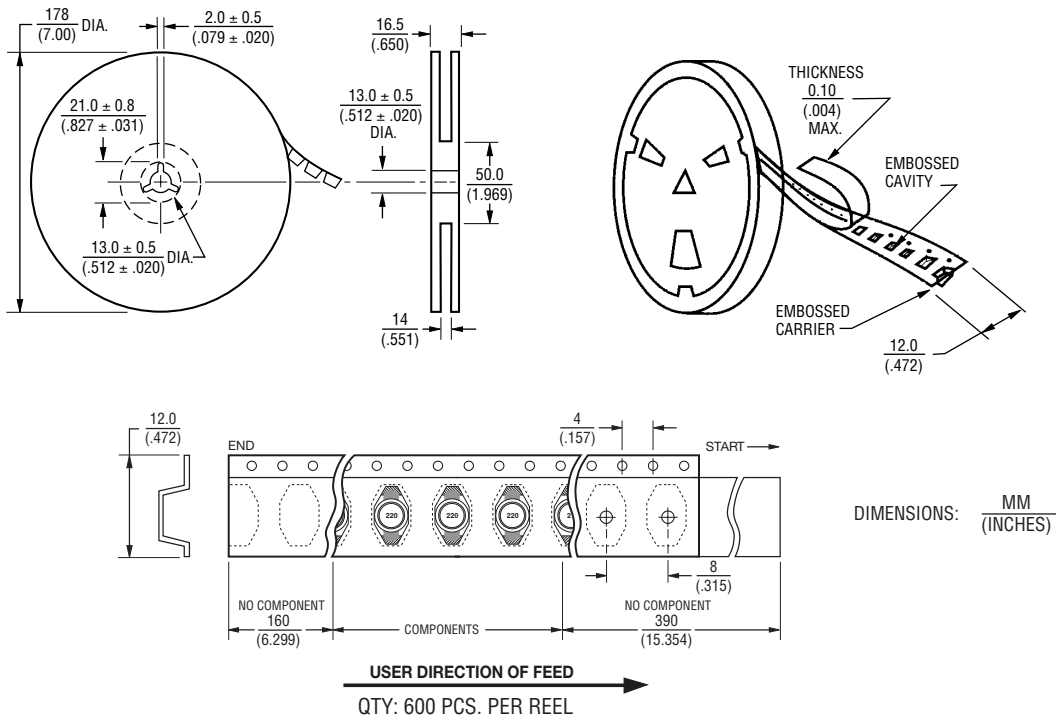

REV. 03/18

Specifications are subject to change without notice.  
The device characteristics and parameters in this data sheet can and do vary in different applications and actual device performance may vary over time.  
Users should verify actual device performance in their specific applications.