

PHYSICAL DIMENSIONS:

A	5.00 [.197]	± 0.15 [.006]
A1	5.88 [.231]	MAX.
B	5.60 [.220]	± 0.10 [.004]
C	2.85 [.112]	± 0.07 [.003]
C1	3.80 [.150]	MAX
E	2.84 [.112]	± 0.10 [.004]

WIRE DIMENSIONS:

T1	1.75 [.069]	± 0.13 [.005]
T2	0.81 [.032]	REF.
T3	0.43 [.017]	REF.
T4	0.86 [.034]	MAX.



CM2021Y330R-10

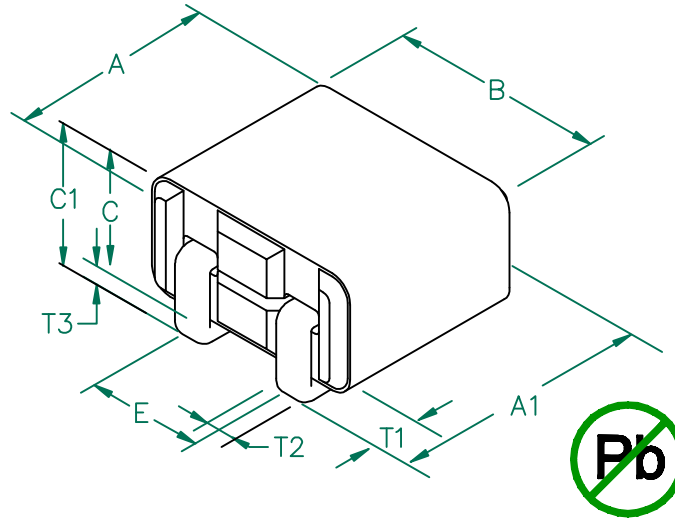

ELECTRICAL CHARACTERISTICS:						
	Z in (Ω)			DCR (Ω)	Rated Current (Continuous)	Rated Voltage (VDC)
	● 25 MHz	● 100 MHz	● 300 MHz			
Nominal (Ref.)	20	33	36			
Minimum	-	25	-			
Maximum	-	-	-	.00075	15,000 mA	140

NOTES: UNLESS OTHERWISE SPECIFIED

1. TAPED AND REELED per CURRENT EIA SPECIFICATIONS, 13" REELS, 2500 PCS PER REEL
2. COMPONENTS SHOULD BE ADEQUATELY PREHEATED BEFORE SOLDERING.
3. REF.CARRIER TAPE SPECIFICATION – PENDING
4. THIS PART HAS NO PIN POLARITY.
5. TERMINATION FINISH IS 100% TIN.
6. OPERATION TEMPERATURE (INCLUDING SELF-HEATING): -40 ~ +125°C.

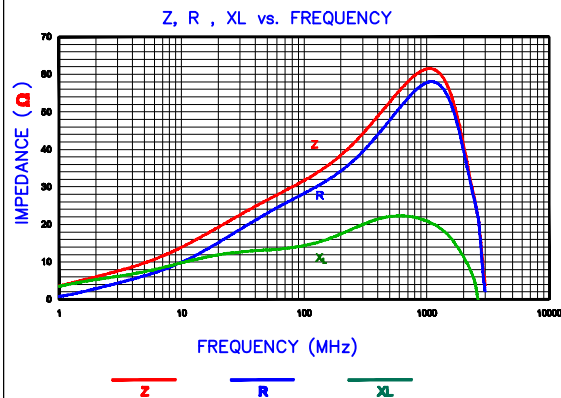
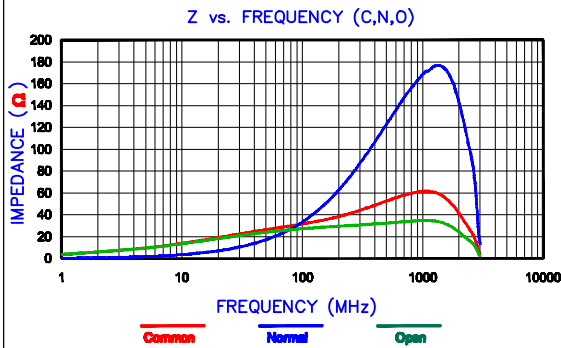
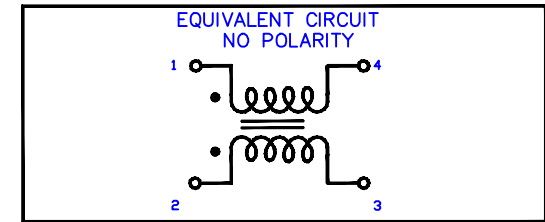

LAND PATTERNS FOR REFLOW SOLDERING

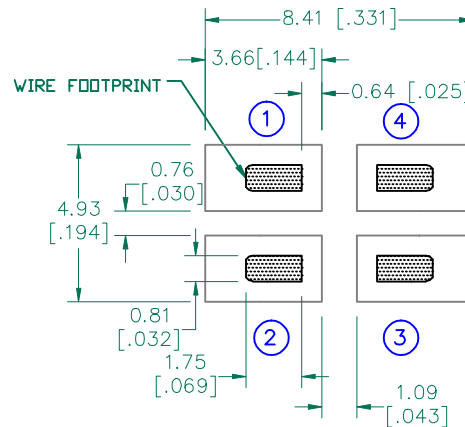

RECOMMENDED SOLDERING CONDITIONS

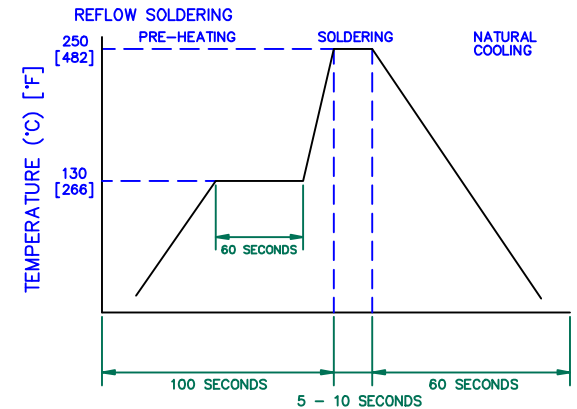

UNCONTROLLED DOCUMENT

DIMENSIONS ARE IN mm [INCHES].				This print is the property of Laird Tech. and is loaned in confidence subject to return upon request and with the understanding that no copies shall be made without the written consent of Laird Tech. All rights to design or invention are reserved.				
H	ADD RATED VOLTAGE AND NOTE 6	08/30/12	QIU	PROJECT/PART NUMBER:		REV	PART TYPE:	DRWN BY:
G	UPDATE COMPANY LOGO	04/28/09	JRK	CM2021Y330R-10		H	ASSEMBLY	JRK
F	CHANGE CORE P/N ON SHEET 3	11/13/07	JRK	DATE:		SCALE:		SHEET:
E	UPDATE COMPANY LOGO	05/17/07	JRK	07/27/05		7 : 1		2 of 3
D	INTERCHANGE DIMENSIONS A,B&C UPDATE CURVES ADD EQUIV CIRCUIT	03/30/06	JRK	DATE:		SCALE:		SHEET:
C	CORRECT T3 DIMS ON SHEET 3	02/20/06	JRK	07/27/05		7 : 1		2 of 3
B	CHG CURRENT RATING FROM 10,000 mA	11/07/05	JRK	DATE:		SCALE:		SHEET:
A	ORIGINAL DRAFT	07/27/05	JRK	07/27/05		7 : 1		2 of 3
REV	DESCRIPTION	DATE	INT	CAD #		TOOL #		
				CM2021Y330R-10-H-2		H0220		



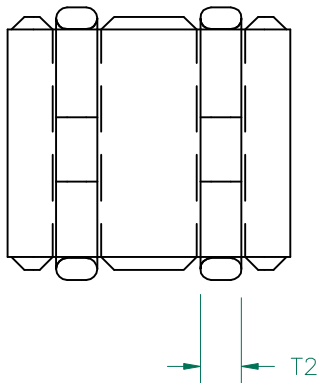
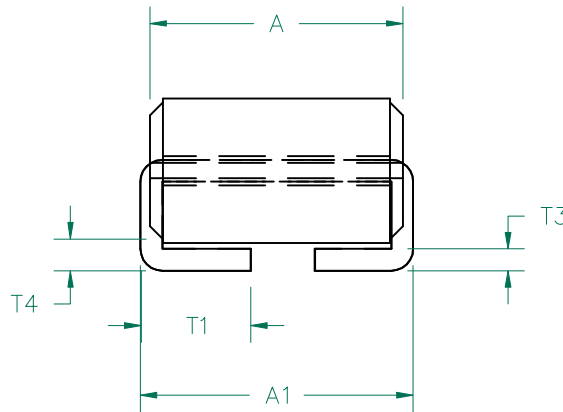
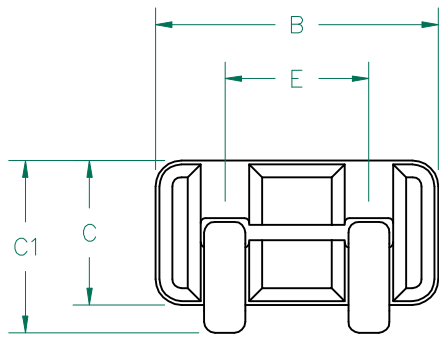

ELECTRICAL TESTING

TEST:	Z	Z	Z
# TURNS	1	1	1
AWG	-	-	-
FREQUENCY	25 MHz	100 MHz	300 MHz
NOMINAL (REF.)	20 Ω	33 Ω	36 Ω
MINIMUM	- Ω	25 Ω	- Ω

CORE WEIGHT/1000 .333 kgs. .736 Lbs.

UNCONTROLLED DOCUMENT



DIMENSIONS:

A	5.00 [.197]	±	0.15 [.006]
A1	5.88 [.231]		MAX.
B	5.60 [.220]	±	0.10 [.004]
C	2.85 [.112]	±	0.07 [.003]
C1	3.80 [.150]	±	MAX
E	2.84 [.112]	±	0.10 [.004]

WIRE DIMENSIONS:

T ₁	1.75 [.069]	+	0.13 [.005]
T ₂	0.81 [.032]	+	REF.
T ₃	0.43 [.017]	+	REF.
T ₄	0.86 [.034]	+	MAX.

NOTES: UNLESS OTHERWISE SPECIFIED

1. IMPEDANCE VALUES ARE GROSS, MEASURED USING W0021-01 WIRE w/ NO D.C. BIAS.
2. REFERENCE STEWARD WIRE PURCHASE SPEC. W0021-01.
3. REFERENCE STEWARD CORE P/N 24H0220-000.
4. TERMINATION FINISH IS 100% TIN.

DIMENSIONS ARE IN mm [INCHES].				This print is the property of Laird Tech. and is loaned in confidence subject to return upon request and with the understanding that no copies shall be made without the written consent of Laird Tech. All rights to design or invention are reserved.		Laird TECHNOLOGIES			
H	ADD RATED VOLTAGE AND NOTE 6	08/30/12	QIU	PROJECT/PART NUMBER: CM2021Y330R-10		REV	PART TYPE:	DRAWN BY:	
G	UPDATE COMPANY LOGO	04/28/09	JRK			H	ASSEMBLY	JRK	
F	CHANGE CORE P/N ON SHEET 3	11/13/07	JRK			DATE: 07/27/05		SCALE: 7 : 1	SHEET:
E	UPDATE COMPANY LOGO	05/17/07	JRK			CAD # CM2021Y330R-10-H-3		TOOL # H0220	3 of 3
D	INTERCHANGE DIMENSIONS A,B&C UPDATE CURVES	03/30/06	JRK			DATE: 07/27/05		SCALE: 7 : 1	SHEET:
C	CORRECT T3 DIMENSION	02/20/06	JRK	DATE: 07/27/05		SCALE: 7 : 1	SHEET:		
B	CHG CURRENT RATING FROM 10,000 mA	11/07/05	JRK	DATE: 07/27/05		SCALE: 7 : 1	SHEET:		
A	ORIGINAL DRAFT	07/27/05	JRK	DATE: 07/27/05		SCALE: 7 : 1	SHEET:		
REV	DESCRIPTION	DATE	INT	DATE: 07/27/05		SCALE: 7 : 1	SHEET:		