

# Varistors (ZNR Surge Absorber)

D type

E series



Varistors (ZNR Surge Absorber), Series E, Type D features large surge current and energy handling capability for absorbing transient overvoltage in a compact size.

## Features

- Large withstanding surge current capability in compact sizes
- Large “Energy Handling Capability” absorbing transient overvoltages in compact sizes
- Wide range of varistor voltages
- RoHS compliant

## Recommended applications

- Transistor, diode, IC, thyristor or triac semiconductor protection
- Surge protection in consumer electronic equipment
- Surge protection in communication, measuring or controller electronics
- Surge protection in electronic home appliances, gas or petroleum appliances

## Applicable standards

- UL1449 (VZCA2/UL, VZCA8/C-UL)
- VDE IEC61051-1, -2, -2-2, IEC60950-1 Annex.Q, IEC62368-1 G8.1
- CQC (GB/T10193, GB/T10194, GB4943.1)

Refer to "Standard Products" , and "Application Note for Safety Standards" , for the details.

Refer to "Standard Products" , and "Application Note for Safety Standards" , for the details.

■ As for handling precautions and minimum quantity / Packing unit please see related information.

## Explanation of part numbers

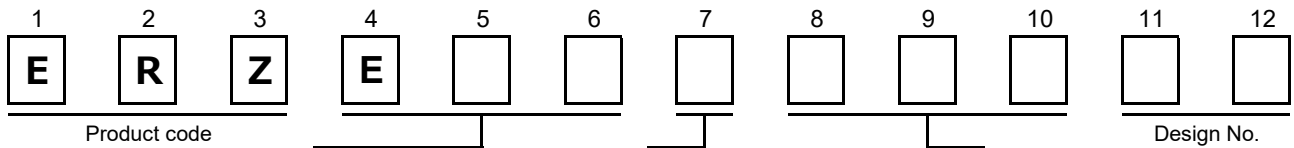

Code	Series
E05	E 5
E07	E7
E08	E8
E10	E10
E11	E11
E14	E14

Lead configuration		
Code	Configuration	Packaging
A	Straight lead	Bulk
B <sup>*1</sup>	Crimped lead	Bulk
E <sup>*2</sup>	Straight lead	Taped
F <sup>*2</sup>	Crimped lead	Taped

**Normal varistor voltage**

The first two digits are significant figures and the third one denotes the number of zeros following.

\*1: Excluding E14, only the lead cut  
\*2: Excluding E14

Reference guide to standard products

Part No.	Applicable standards		Varistor voltage at 1 mA (V)	Maximum allowable voltage		Clamping voltage at 8/20 μs		Maximum peak current at 8/20 μs (A)	
	Type name	Approvals		Acrms (V)	DC (V)	max.(V)	Ip (A)	1 time	2 times
ERZE05A201	E201	○☆◇	200 (185 to 225)	130	170	340	10	1200	600
ERZE07A201	E7201	○☆◇				340	25	2500	1250
ERZE08A201	E8201	○☆◇				340	25	3500	2500
ERZE10A201	E10201	○☆◇				340	50	4500	3000
ERZE11A201	E11201	○☆★◇◆				340	50	6000	5000
ERZE14A201	E14201	○☆★◇◆				340	100	10000	7000
ERZE05A221	E221	○☆◇	220 (198 to 242)	140	180	360	10	1200	600
ERZE07A221	E7221	○☆◇				360	25	2500	1250
ERZE08A221	E8221	○☆◇				360	25	3500	2500
ERZE10A221	E10221	○☆◇				360	50	4500	3000
ERZE11A221	E11221	○☆★◇◆				360	50	6000	5000
ERZE14A221	E14221	○☆★◇◆				360	100	10000	7000
ERZE05A241	E241	○☆◇	240 (216 to 264)	150	200	395	10	1200	600
ERZE07A241	E7241	○☆◇				395	25	2500	1250
ERZE08A241	E8241	○☆◇				395	25	3500	2500
ERZE10A241	E10241	○☆◇				395	50	4500	3000
ERZE11A241	E11241	○☆★◇◆				395	50	6000	5000
ERZE14A241	E14241	○☆★◇◆				395	100	10000	7000
ERZE05A271	E271	○☆◇	270 (247 to 303)	175	225	455	10	1200	600
ERZE07A271	E7271	○☆◇				455	25	2500	1250
ERZE08A271	E8271	○☆◇				455	25	3500	2500
ERZE10A271	E10271	○☆◇				455	50	4500	3000
ERZE11A271	E11271	○☆★◇◆				455	50	6000	5000
ERZE14A271	E14271	○☆★◇◆				455	100	10000	7000
ERZE05A331	E331	○☆◇	330 (297 to 363)	210	270	545	10	1200	600
ERZE07A331	E7331	○☆◇				545	25	2500	1250
ERZE08A331	E8331	○☆◇				545	25	3500	2500
ERZE10A331	E10331	○☆◇				545	50	4500	3000
ERZE11A331	E11331	○☆★◇◆				545	50	6000	4500
ERZE14A331	E14331	○☆★◇◆				545	100	10000	6500
ERZE05A361	E361	○☆◇	360 (324 to 396)	230	300	595	10	1200	600
ERZE07A361	E7361	○☆◇				595	25	2500	1250
ERZE08A361	E8361	○☆◇				595	25	3500	2500
ERZE10A361	E10361	○☆◇				595	50	4500	3000
ERZE11A361	E11361	○☆★◇◆				595	50	6000	4500
ERZE14A361	E14361	○☆★◇◆				595	100	10000	6500
ERZE05A391	E391	○☆◇	390 (351 to 429)	250	320	650	10	1200	600
ERZE07A391	E7391	○☆◇				650	25	2500	1250
ERZE08A391	E8391	○☆◇				650	25	3500	2500
ERZE10A391	E10391	○☆◇				650	50	4500	3000
ERZE11A391	E11391	○☆★◇◆				650	50	6000	4500
ERZE14A391	E14391	○☆★◇◆				650	100	10000	6500
ERZE05A431	E431	○☆◇	430 (387 to 473)	275	350	710	10	1200	600
ERZE07A431	E7431	○☆◇				710	25	2500	1250
ERZE08A431	E8431	○☆◇				710	25	3500	2500
ERZE10A431	E10431	○☆◇				710	50	4500	3000
ERZE11A431	E11431	○☆★◇◆				710	50	6000	4500
ERZE14A431	E14431	○☆★◇◆				710	100	10000	6500

○: UL1449 (VZCA2/UL, VZCA8/C-UL), ☆: VDE (IEC61051-1, -2, -2-2) ★: VDE (IEC60950-1 Annex.Q, IEC62368-1 G8.1),

◇: CQC (GB/T10193, GB/T10194), ◆: CQC (GB4943.1)

※Approval number (File No.) of safety regulations are subject to revision without notice. Ask factory for a copy of the latest file No.

## Reference guide to standard products

Part No.	Applicable standards		Varistor voltage at 1 mA (V)	Maximum allowable voltage		Clamping voltage at 8/20 $\mu$ s		Maximum peak current at 8/20 $\mu$ s (A)	
	Type name	Approvals		Acrms (V)	DC (V)	max.(V)	Ip (A)	1 time	2 times
ERZE05A471	E471	○☆◇	470 (423 to 517)	300	385	775	10	1200	600
ERZE07A471	E7471	○☆◇				775	25	2500	1250
ERZE08A471	E8471	○☆★◇◆				775	25	3500	2500
ERZE10A471	E10471	○☆★◇◆				775	50	4500	3000
ERZE11A471	E11471	○☆★◇◆				775	50	6000	4500
ERZE14A471	E14471	○☆★◇◆				775	100	10000	6500
ERZE07A511	E7511	○☆◇	510 (459 to 561)	320	410	845	25	2500	1250
ERZE08A511	E8511	○☆★◇◆				845	25	3500	2500
ERZE10A511	E10511	○☆★◇◆				845	50	4500	3000
ERZE11A511	E11511	○☆★◇◆				845	50	6000	4500
ERZE14A511	E14511	○☆★◇◆				845	100	10000	6500
ERZE07A561	E7561	○☆◇	560 (504 to 616)	350	450	930	25	2500	1250
ERZE08A561	E8561	○☆★◇◆				930	25	3500	2500
ERZE10A561	E10561	○☆★◇◆				930	50	4500	3000
ERZE11A561	E11561	○☆★◇◆				930	50	6000	4500
ERZE14A561	E14561	○☆★◇◆				930	100	10000	6500
ERZE07A621	E7621	○☆◇	620 (558 to 682)	385	505	1025	25	2500	1250
ERZE08A621	E8621	○☆★◇◆				1025	25	3500	2500
ERZE10A621	E10621	○☆★◇◆				1025	50	4500	3000
ERZE11A621	E11621	○☆★◇◆				1025	50	5000	4500
ERZE14A621	E14621	○☆★◇◆				1025	100	7500	6500
ERZE08A681	E8681	○☆★◇◆	680 (612 to 748)	420	560	1120	25	3500	2500
ERZE10A681	E10681	○☆★◇◆				1120	50	4500	3000
ERZE11A681	E11681	○☆★◇◆				1120	50	5000	4500
ERZE14A681	E14681	○☆★◇◆				1120	100	7500	6500
ERZE08A751	E8751	○☆★◇◆	750 (675 to 825)	460	615	1240	25	3500	2500
ERZE10A751	E10751	○☆★◇◆				1240	50	4500	3000
ERZE11A751	E11751	○☆★◇◆				1240	50	5000	4500
ERZE14A751	E14751	○☆★◇◆				1240	100	7500	6500
ERZE10A821	E10821	○☆★◇◆	820 (738 to 902)	510	670	1355	50	4500	3000
ERZE11A821	E11821	○☆★◇◆				1355	50	5000	4500
ERZE14A821	E14821	○☆★◇◆				1355	100	7500	6500
ERZE10A911	E10911	○☆★◇◆	910 (819 to 1001)	550	745	1500	50	4500	3000
ERZE11A911	E11911	○☆★◇◆				1500	50	5000	4500
ERZE14A911	E14911	○☆★◇◆				1500	100	7500	6500
ERZE10A102	E10102	○☆★◇◆	1000 (900 to 1100)	625	825	1650	50	4500	3000
ERZE11A102	E11102	○☆★◇◆				1650	50	5000	4500
ERZE14A102	E14102	○☆★◇◆				1650	100	7500	6500
ERZE10A112	E10112	○☆★◇◆	1100 (990 to 1210)	680	895	1815	50	4500	3000
ERZE11A112	E11112	○☆★◇◆				1815	50	5000	4500
ERZE14A112	E14112	○☆★◇◆				1815	100	7500	6500

○: UL1449 (VZCA2/UL, VZCA8/C-UL), ☆: VDE (IEC61051-1, -2, -2-2) ★: VDE (IEC60950-1 Annex.Q, IEC62368-1 G8.1),

◇: CQC (GB/T10193, GB/T10194), ◆: CQC (GB4943.1)

※Approval number (File No.) of safety regulations are subject to revision without notice. Ask factory for a copy of the latest file No.

## Ratings and characteristics

●Operating temperature range : -40 to 85 °C

●Storage temperature range : -40 to 125 °C

Part No.	Varistor voltage at 1 mA	Maximum allowable voltage		Clamping voltage (max.) **Ip	Rated power	Maximum energy		Maximum peak current (8/20 μs)		Capacitance (max.) at 1 kHz
		ACrms (V)	DC (V)			(10/1000 μs)	(2 ms)	1 time	2 times	
	(V)	(V)	(V)	(V)	(W)	(J)	(J)	(A)	(A)	(pF)
ERZE05A201	200(185 to 225)	130	170	340	0.25	13	9.5	1200	600	200
ERZE05A221	220(198 to 242)	140	180	360	0.25	14	10	1200	600	190
ERZE05A241	240(216 to 264)	150	200	395	0.25	15	11	1200	600	170
ERZE05A271	270(247 to 303)	175	225	455	0.25	18	13	1200	600	150
ERZE05A331	330(297 to 363)	210	270	545	0.25	21	15	1200	600	130
ERZE05A361	360(324 to 396)	230	300	595	0.25	23	17	1200	600	130
ERZE05A391	390(351 to 429)	250	320	650	0.25	26	19	1200	600	130
ERZE05A431	430(387 to 473)	275	350	710	0.25	29	21	1200	600	120
ERZE05A471	470(423 to 517)	300	385	775	0.25	32	23	1200	600	100

\*Ip Measuring current of clamping voltage : 10 A

## Dimensions in mm (not to scale)

Unit : mm

Part No.	D max.	T max.	F±1.0	A max.	L±1.0
ERZE05A201	7.0	4.8	5.0	10.0	2.1
ERZE05A221	7.0	4.9	5.0	10.0	2.3
ERZE05A241	7.0	5.0	5.0	10.0	2.4
ERZE05A271	7.0	5.2	5.0	10.0	2.5
ERZE05A331	7.0	5.5	5.0	10.0	2.9
ERZE05A361	7.0	5.8	5.0	10.0	3.1
ERZE05A391	7.0	5.9	5.0	10.0	3.2
ERZE05A431	7.0	6.1	5.0	10.0	3.3
ERZE05A471	7.0	6.3	5.0	10.0	3.5

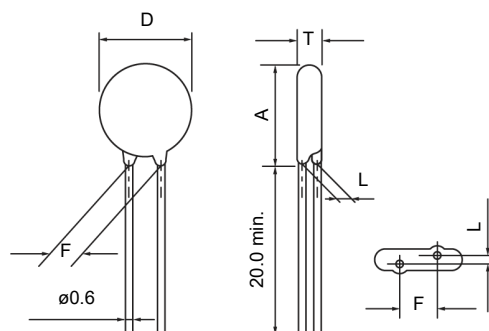

**Typical characteristics**

**Voltage vs. Current**

ERZE05A201 to ERZE05A471

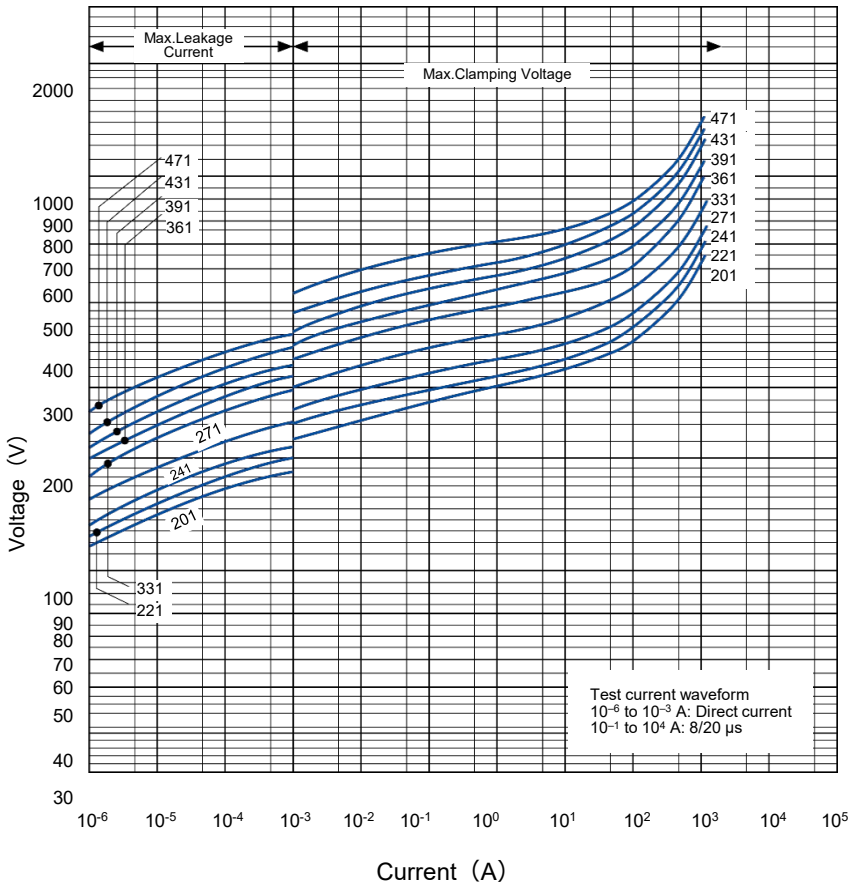

**Impulse Derating** (Relation between impulse width and impulse current multiple)

ERZE05A201 to ERZE05A471

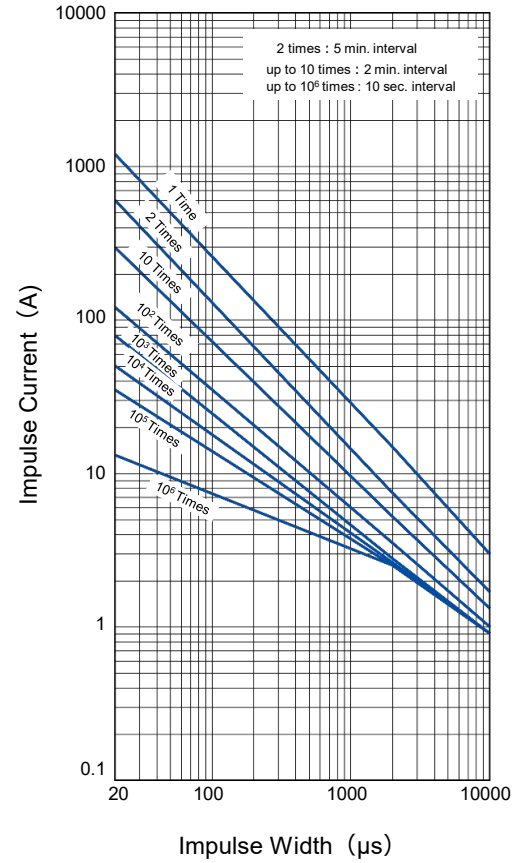

## Ratings and characteristics

●Operating temperature range : -40 to 85 °C

●Storage temperature range : -40 to 125 °C

Part No.	Varistor voltage at 1 mA	Maximum allowable voltage		Clamping voltage (max.) **Ip	Rated power	Maximum energy		Maximum peak current (8/20 μs)		Capacitance (max.) at 1 kHz
		ACrms (V)	DC (V)			(10/1000 μs)	(2 ms)	1 time	2 times	
	(V)	(V)	(V)	(V)	(W)	(J)	(J)	(A)	(A)	(pF)
ERZE07A201	200(185 to 225)	130	170	340	0.3	26	19	2500	1250	360
ERZE07A221	220(198 to 242)	140	180	360	0.3	30	22	2500	1250	350
ERZE07A241	240(216 to 264)	150	200	395	0.3	33	24	2500	1250	340
ERZE07A271	270(247 to 303)	175	225	455	0.3	39	28	2500	1250	310
ERZE07A331	330(297 to 363)	210	270	545	0.3	44	32	2500	1250	280
ERZE07A361	360(324 to 396)	230	300	595	0.3	50	36	2500	1250	260
ERZE07A391	390(351 to 429)	250	320	650	0.3	53	38	2500	1250	240
ERZE07A431	430(387 to 473)	275	350	710	0.3	60	43	2500	1250	210
ERZE07A471	470(423 to 517)	300	385	775	0.3	65	47	2500	1250	170
ERZE07A511	510(459 to 561)	320	410	845	0.3	70	50	2500	1250	140
ERZE07A561	560(504 to 616)	350	450	930	0.3	75	55	2500	1250	140
ERZE07A621	620(558 to 682)	385	505	1025	0.3	80	60	2500	1250	135

\*Ip Measuring current of clamping voltage : 25 A

## Dimensions in mm (not to scale)

Unit : mm

Part No.	D max.	T max.	F±1.0	A max.	L±1.0
ERZE07A201	9.0	5.3	7.5	12.5	2.1
ERZE07A221	9.0	5.4	7.5	12.5	2.3
ERZE07A241	9.0	5.5	7.5	12.5	2.4
ERZE07A271	9.0	5.7	7.5	12.5	2.5
ERZE07A331	9.0	6.0	7.5	12.5	2.8
ERZE07A361	9.0	6.2	7.5	12.5	2.9
ERZE07A391	9.0	6.3	7.5	12.5	3.0
ERZE07A431	9.0	6.5	7.5	12.5	3.1
ERZE07A471	9.0	6.8	7.5	12.5	3.3
ERZE07A511	9.0	7.0	7.5	12.5	3.5
ERZE07A561	9.0	7.4	7.5	13.5	3.8
ERZE07A621	10.0	7.8	7.5	13.5	4.0

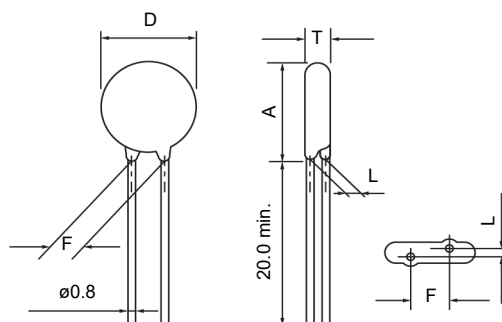

**Typical characteristics**

**Voltage vs. Current**

ERZE07A201 to ERZE07A621

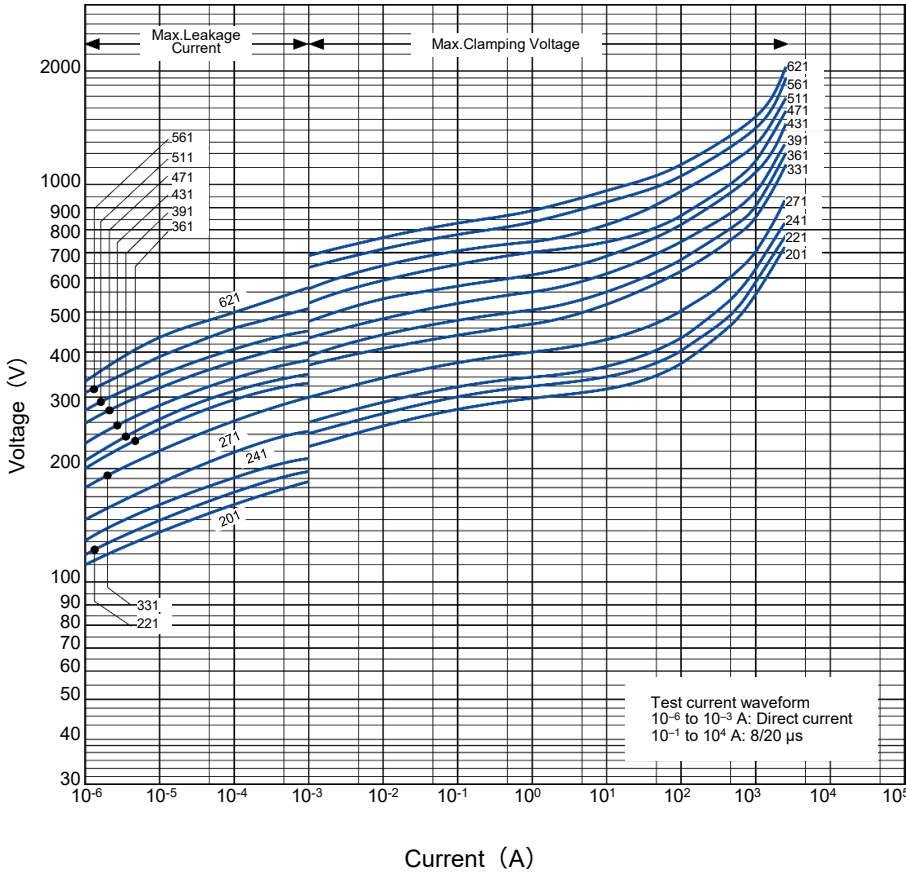

**Impulse Derating** (Relation between impulse width and impulse current multiple)

ERZE07A201 to ERZE07A621

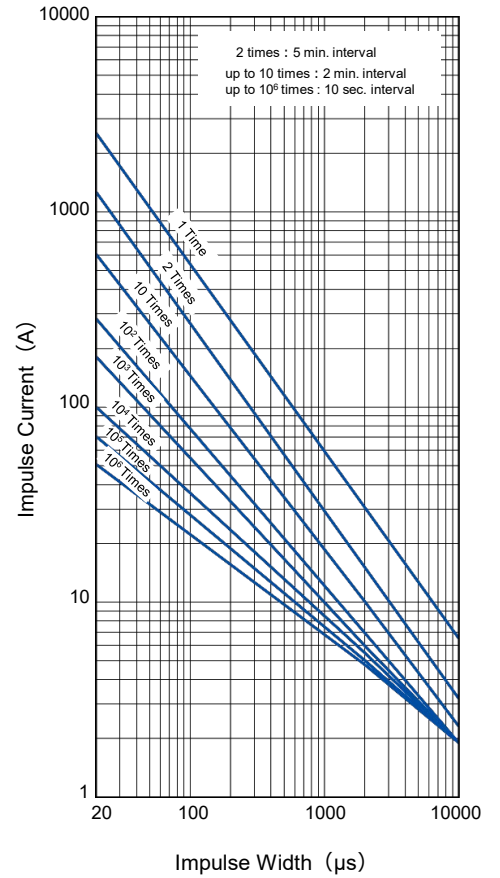

## Ratings and characteristics

● Operating temperature range : -40 to 85 °C ● Storage temperature range : -40 to 125 °C

Part No.	Varistor voltage at 1 mA	Maximum allowable voltage		Clamping voltage (max.) **Ip	Rated power	Maximum energy		Maximum peak current (8/20 μs)		Capacitance (max.) at 1 kHz
		ACrms (V)	DC (V)			(10/1000 μs)	(2 ms)	1 time	2 times	
	(V)	(V)	(V)	(W)	(J)	(J)	(A)	(A)	(pF)	
ERZE08A201	200(185 to 225)	130	170	340	0.4	35	25	3500	2500	390
ERZE08A221	220(198 to 242)	140	180	360	0.4	39	27.5	3500	2500	380
ERZE08A241	240(216 to 264)	150	200	395	0.4	42	30	3500	2500	360
ERZE08A271	270(247 to 303)	175	225	455	0.4	49	35	3500	2500	330
ERZE08A331	330(297 to 363)	210	270	545	0.4	58	42	3500	2500	300
ERZE08A361	360(324 to 396)	230	300	595	0.4	65	45	3500	2500	280
ERZE08A391	390(351 to 429)	250	320	650	0.4	70	50	3500	2500	260
ERZE08A431	430(387 to 473)	275	350	710	0.4	80	55	3500	2500	230
ERZE08A471	470(423 to 517)	300	385	775	0.4	85	60	3500	2500	220
ERZE08A511	510(459 to 561)	320	410	845	0.4	92	67	3500	2500	210
ERZE08A561	560(504 to 616)	350	450	930	0.4	92	67	3500	2500	190
ERZE08A621	620(558 to 682)	385	505	1025	0.4	92	67	3500	2500	180
ERZE08A681	680(612 to 748)	420	560	1120	0.4	92	67	3500	2500	170
ERZE08A751	750(675 to 825)	460	615	1240	0.4	100	70	3500	2500	160

\*Ip Measuring current of clamping voltage : 25 A

## Dimensions in mm (not to scale)

Unit : mm

Part No.	D max.	T max.	F±1.0	A max.	L±1.0
ERZE08A201	10.5	5.1	7.5	13.5	1.9
ERZE08A221	10.5	5.2	7.5	13.5	2.0
ERZE08A241	10.5	5.3	7.5	13.5	2.1
ERZE08A271	10.5	5.5	7.5	13.5	2.3
ERZE08A331	10.5	5.9	7.5	13.5	2.6
ERZE08A361	10.5	6.1	7.5	13.5	2.8
ERZE08A391	10.5	6.3	7.5	13.5	2.9
ERZE08A431	10.5	6.5	7.5	13.5	3.1
ERZE08A471	10.5	7.3	7.5	13.5	3.6
ERZE08A511	10.5	7.8	7.5	13.5	4.0
ERZE08A561	10.5	8.1	7.5	13.5	4.3
ERZE08A621	11.5	8.7	7.5	14.5	4.7
ERZE08A681	11.5	9.0	7.5	14.5	5.0
ERZE08A751	11.5	9.7	7.5	14.5	5.6

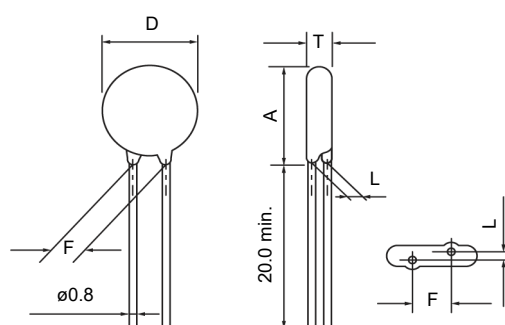

**Typical characteristics**

**Voltage vs. Current**

ERZE08A201 to ERZE08A511

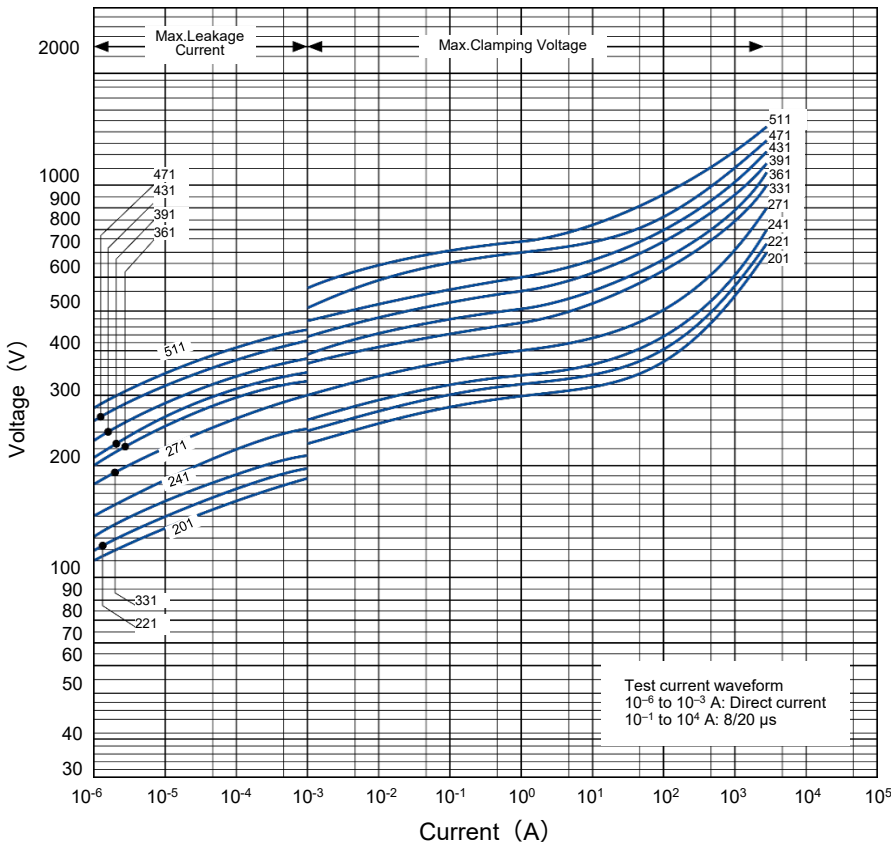

**Impulse Derating** (Relation between impulse width and impulse current multiple)

ERZE08A201 to ERZE08A511

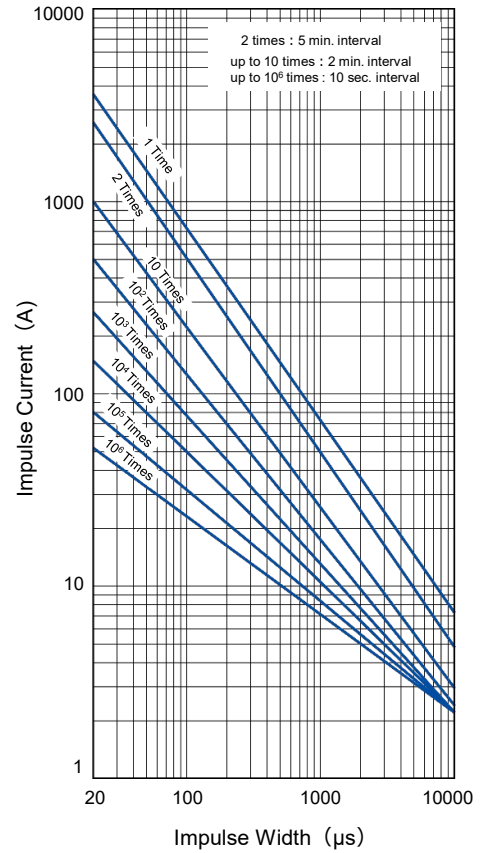

ERZE08A561 to ERZE08A751

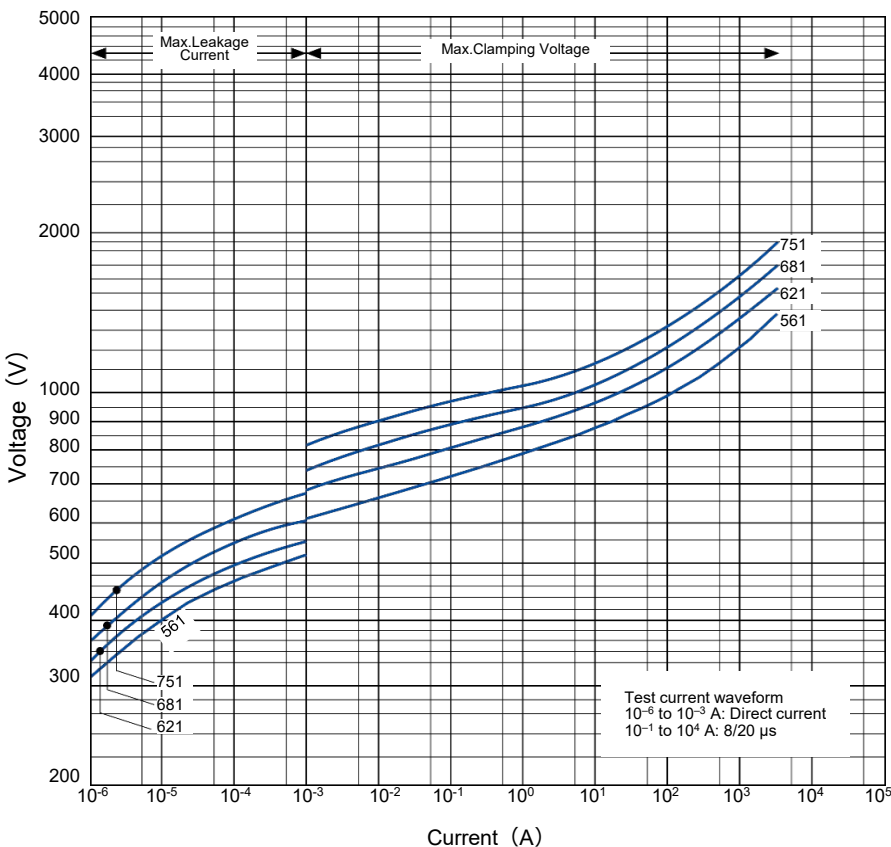

ERZE08A561 to ERZE08A751

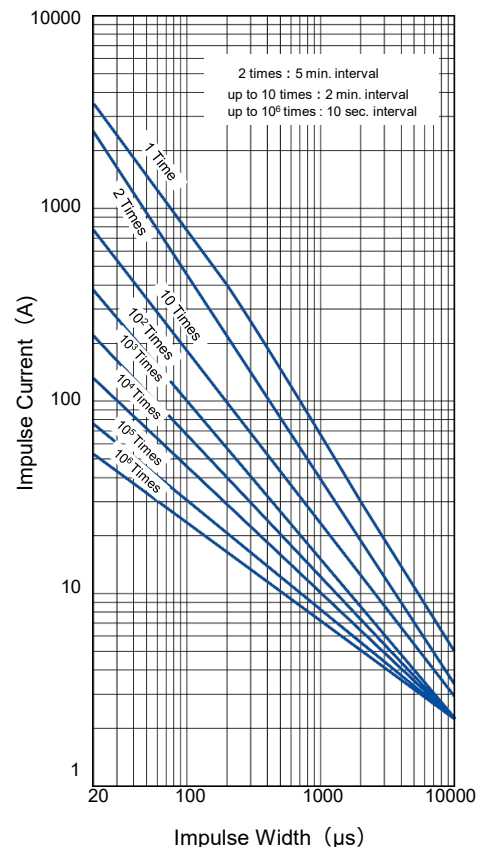

## Ratings and characteristics

●Operating temperature range : -40 to 85 °C

●Storage temperature range : -40 to 125 °C

Part No.	Varistor voltage at 1 mA	Maximum allowable voltage		Clamping voltage (max.) **Ip	Rated power	Maximum energy		Maximum peak current (8/20 $\mu$ s)		Capacitance (max.) at 1 kHz
		ACrms (V)	DC (V)			(10/1000 $\mu$ s)	(2 ms)	1 time	2 times	
	(V)	(V)	(V)	(W)	(J)	(J)	(A)	(A)	(pF)	
ERZE10A201	200(185 to 225)	130	170	340	0.5	47	34	4500	3000	630
ERZE10A221	220(198 to 242)	140	180	360	0.5	50	36	4500	3000	600
ERZE10A241	240(216 to 264)	150	200	395	0.5	56	40	4500	3000	570
ERZE10A271	270(247 to 303)	175	225	455	0.5	64	46	4500	3000	530
ERZE10A331	330(297 to 363)	210	270	545	0.5	72	52	4500	3000	470
ERZE10A361	360(324 to 396)	230	300	595	0.5	84	60	4500	3000	430
ERZE10A391	390(351 to 429)	250	320	650	0.5	91	65	4500	3000	400
ERZE10A431	430(387 to 473)	275	350	710	0.5	99	71	4500	3000	350
ERZE10A471	470(423 to 517)	300	385	775	0.5	106	76	4500	3000	320
ERZE10A511	510(459 to 561)	320	410	845	0.5	117	84	4500	3000	300
ERZE10A561	560(504 to 616)	350	450	930	0.5	120	86	4500	3000	290
ERZE10A621	620(558 to 682)	385	505	1025	0.5	126	88	4500	3000	280
ERZE10A681	680(612 to 748)	420	560	1120	0.5	133	95	4500	3000	260
ERZE10A751	750(675 to 825)	460	615	1240	0.5	140	100	4500	3000	250
ERZE10A821	820(738 to 902)	510	670	1355	0.5	154	110	4500	3000	230
ERZE10A911	910(819 to 1001)	550	745	1500	0.5	168	112	4500	3000	220
ERZE10A102	1000(900 to 1100)	625	825	1650	0.5	182	130	4500	3000	200
ERZE10A112	1100(990 to 1210)	680	895	1815	0.5	196	140	4500	3000	180

\*Ip Measuring current of clamping voltage : 50 A

## Dimensions in mm (not to scale)

Unit : mm

Part No.	D max.	T max.	F $\pm$ 1.0	A max.	L $\pm$ 1.0
ERZE10A201	11.5	5.3	7.5	15.0	2.1
ERZE10A221	11.5	5.4	7.5	15.0	2.3
ERZE10A241	11.5	5.5	7.5	15.0	2.4
ERZE10A271	11.5	5.7	7.5	15.0	2.5
ERZE10A331	11.5	6.0	7.5	15.0	2.8
ERZE10A361	11.5	6.2	7.5	15.0	2.9
ERZE10A391	11.5	6.3	7.5	15.0	3.0
ERZE10A431	11.5	6.5	7.5	15.0	3.1
ERZE10A471	11.5	6.8	7.5	15.0	3.3
ERZE10A511	11.5	7.0	7.5	15.0	3.5
ERZE10A561	11.5	7.4	7.5	15.0	3.8
ERZE10A621	12.5	7.8	7.5	16.0	4.0
ERZE10A681	12.5	8.1	7.5	16.0	4.2
ERZE10A751	12.5	8.6	7.5	16.0	4.6
ERZE10A821	12.5	8.9	7.5	16.0	5.0
ERZE10A911	12.5	9.5	7.5	16.0	5.7
ERZE10A102	12.5	10.0	7.5	16.0	6.2
ERZE10A112	12.5	10.6	7.5	16.0	6.8

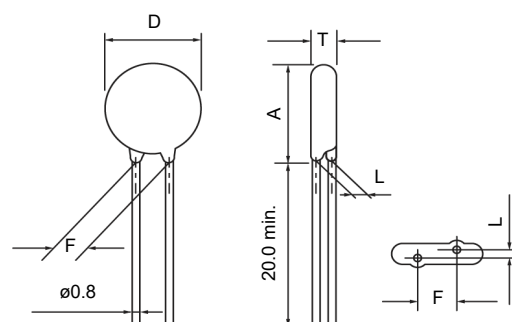

Typical characteristics

Voltage vs. Current

ERZE10A201 to ERZE10A561

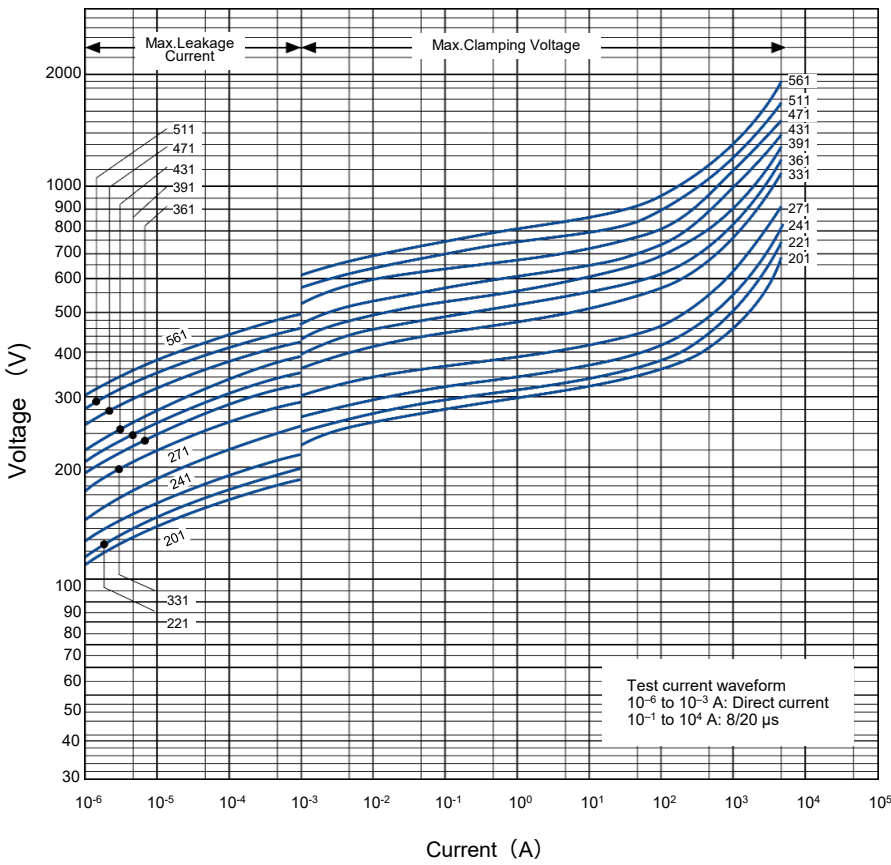

Impulse Derating (Relation between impulse width and impulse current multiple)

ERZE10A201 to ERZE10A561

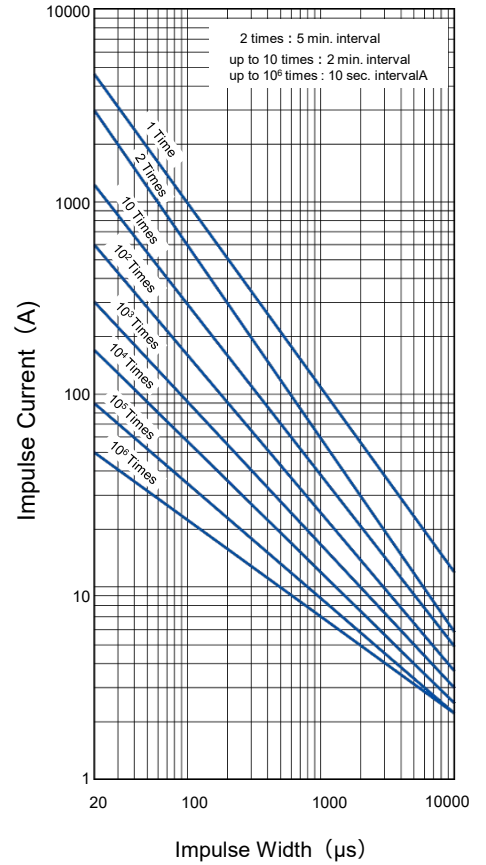

ERZE10A621 to ERZE10A112

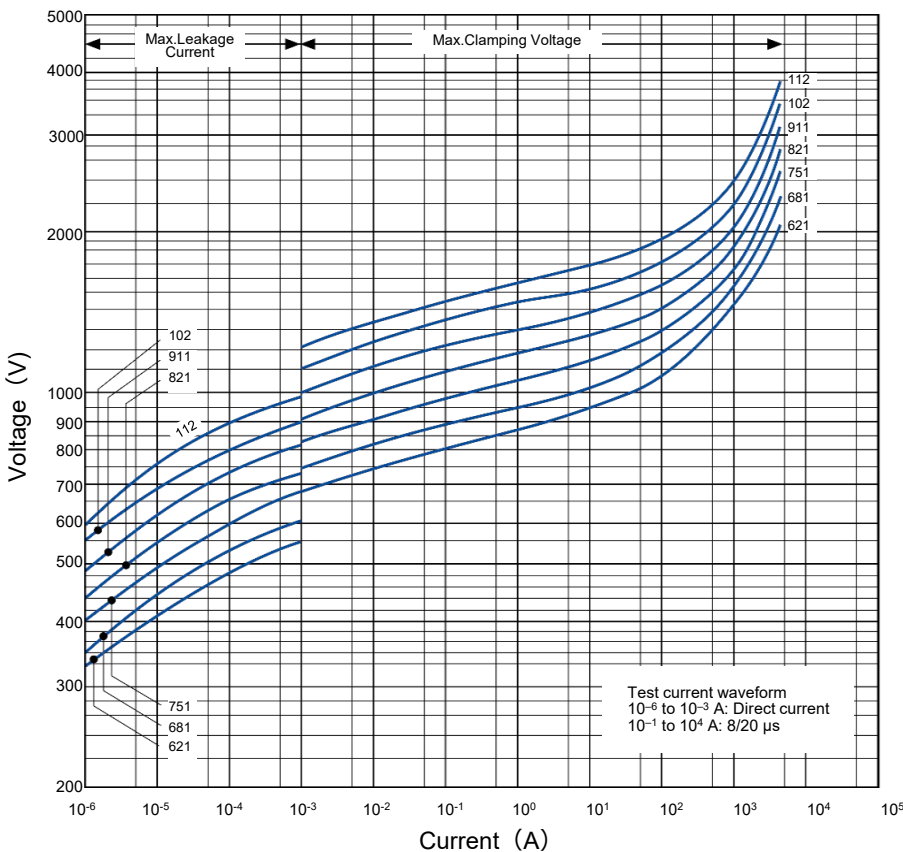

ERZE10A621 to ERZE10A112

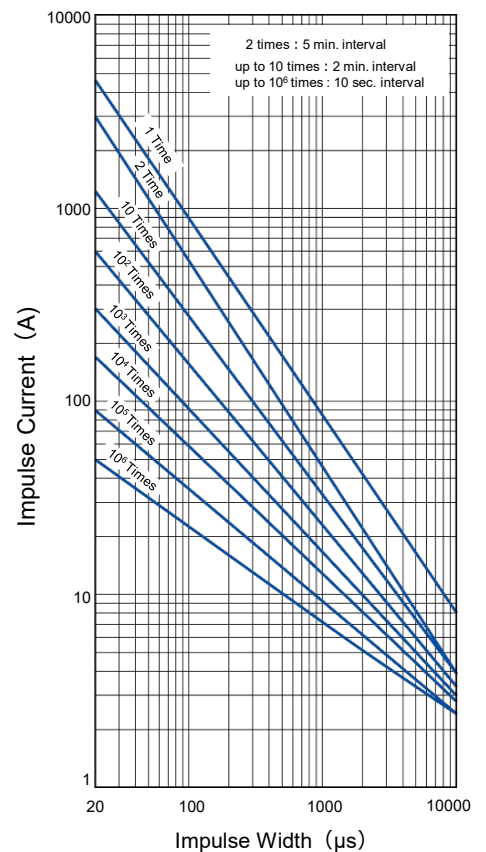

## Ratings and characteristics

●Operating temperature range : -40 to 85 °C

●Storage temperature range : -40 to 125 °C

Part No.	Varistor voltage at 1 mA	Maximum allowable voltage		Clamping voltage (max.) **Ip	Rated power	Maximum energy		Maximum peak current (8/20 $\mu$ s)		Capacitance (max.) at 1 kHz
		ACrms (V)	DC (V)			(10/1000 $\mu$ s)	(2 ms)	1 time	2 times	
	(V)	(V)	(V)	(W)	(J)	(J)	(A)	(A)	(pF)	
ERZE11A201	200(185 to 225)	130	170	340	0.6	70	50	6000	5000	690
ERZE11A221	220(198 to 242)	140	180	360	0.6	78	55	6000	5000	660
ERZE11A241	240(216 to 264)	150	200	395	0.6	84	60	6000	5000	620
ERZE11A271	270(247 to 303)	175	225	455	0.6	99	70	6000	5000	580
ERZE11A331	330(297 to 363)	210	270	545	0.6	115	80	6000	4500	520
ERZE11A361	360(324 to 396)	230	300	595	0.6	130	90	6000	4500	480
ERZE11A391	390(351 to 429)	250	320	650	0.6	140	100	6000	4500	450
ERZE11A431	430(387 to 473)	275	350	710	0.6	155	110	6000	4500	400
ERZE11A471	470(423 to 517)	300	385	775	0.6	175	125	6000	4500	360
ERZE11A511	510(459 to 561)	320	410	845	0.6	190	136	6000	4500	310
ERZE11A561	560(504 to 616)	350	450	930	0.6	190	136	6000	4500	310
ERZE11A621	620(558 to 682)	385	505	1025	0.6	190	136	5000	4500	300
ERZE11A681	680(612 to 748)	420	560	1120	0.6	190	136	5000	4500	290
ERZE11A751	750(675 to 825)	460	615	1240	0.6	210	150	5000	4500	280
ERZE11A821	820(738 to 902)	510	670	1355	0.6	235	165	5000	4500	260
ERZE11A911	910(819 to 1001)	550	745	1500	0.6	255	180	5000	4500	240
ERZE11A102	1000(900 to 1100)	625	825	1650	0.6	280	200	5000	4500	220
ERZE11A112	1100(990 to 1210)	680	895	1815	0.6	310	220	5000	4500	200

\*Ip Measuring current of clamping voltage : 50 A

## Dimensions in mm (not to scale)

Unit : mm

Part No.	D max.	T max.	F $\pm$ 1.0	A max.	L $\pm$ 1.0
ERZE11A201	13.0	5.2	7.5	17.0	1.9
ERZE11A221	13.0	5.3	7.5	17.0	2.0
ERZE11A241	13.0	5.4	7.5	17.0	2.1
ERZE11A271	13.0	5.6	7.5	17.0	2.3
ERZE11A331	13.0	5.9	7.5	17.0	2.6
ERZE11A361	13.0	6.1	7.5	17.0	2.8
ERZE11A391	13.0	6.2	7.5	17.0	2.9
ERZE11A431	13.0	6.4	7.5	17.0	3.1
ERZE11A471	13.0	6.6	7.5	17.0	3.3
ERZE11A511	13.0	6.8	7.5	17.0	3.5
ERZE11A561	13.0	7.2	7.5	17.0	3.8
ERZE11A621	14.0	7.5	7.5	18.0	4.2
ERZE11A681	14.0	7.8	7.5	18.0	4.5
ERZE11A751	14.0	8.2	7.5	18.0	4.9
ERZE11A821	14.0	8.5	7.5	18.0	5.2
ERZE11A911	14.0	9.0	7.5	18.0	5.7
ERZE11A102	14.0	9.5	7.5	18.0	6.2
ERZE11A112	14.0	10.1	7.5	18.0	6.8

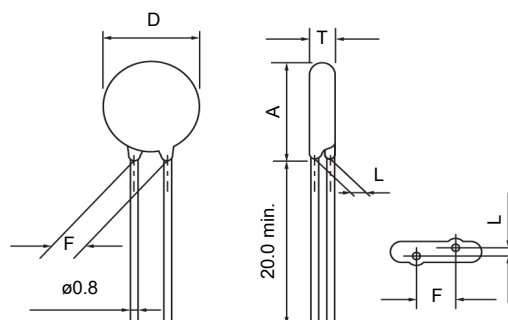

Typical characteristics

Voltage vs. Current

ERZE11A201 to ERZE11A511

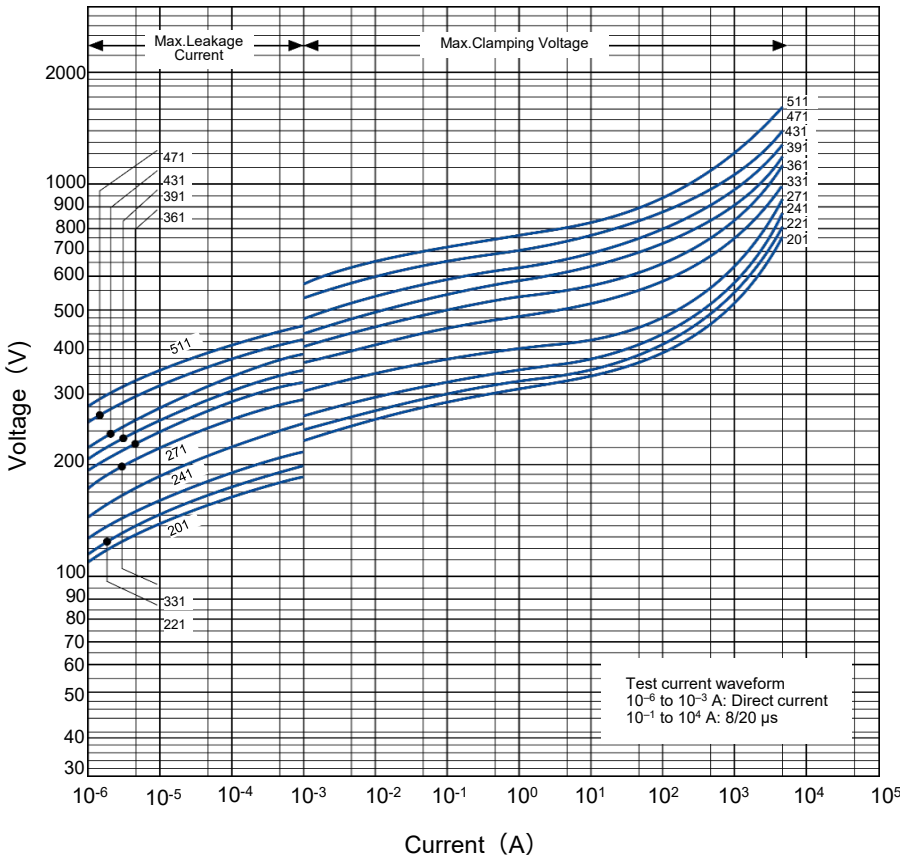

Impulse Derating (Relation between impulse width and impulse current multiple)

ERZE11A201 to ERZE11A511

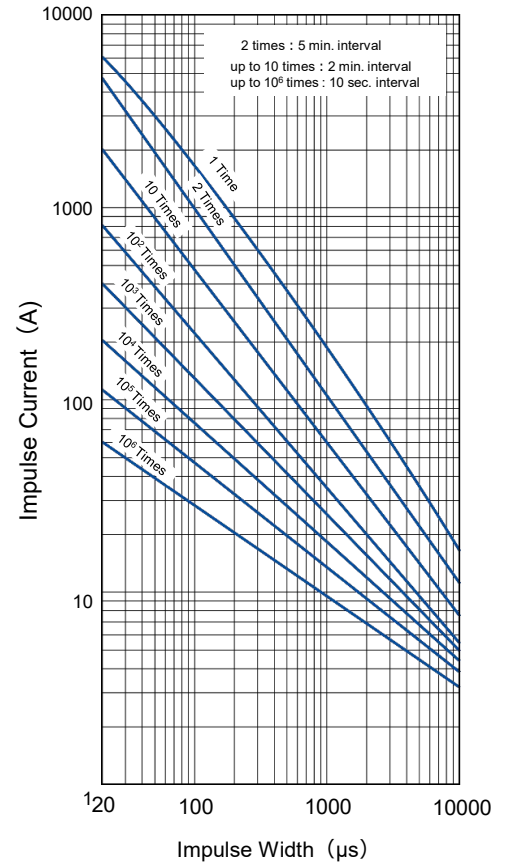

ERZE11A561 to ERZE11A112

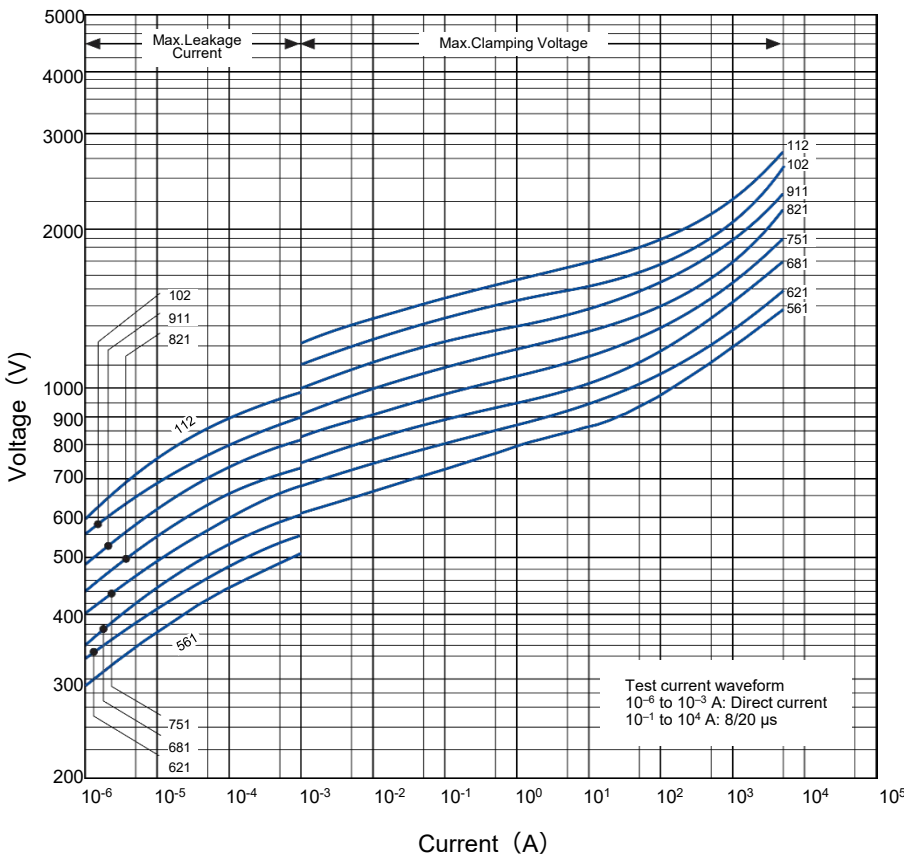

ERZE11A561 to ERZE11A112

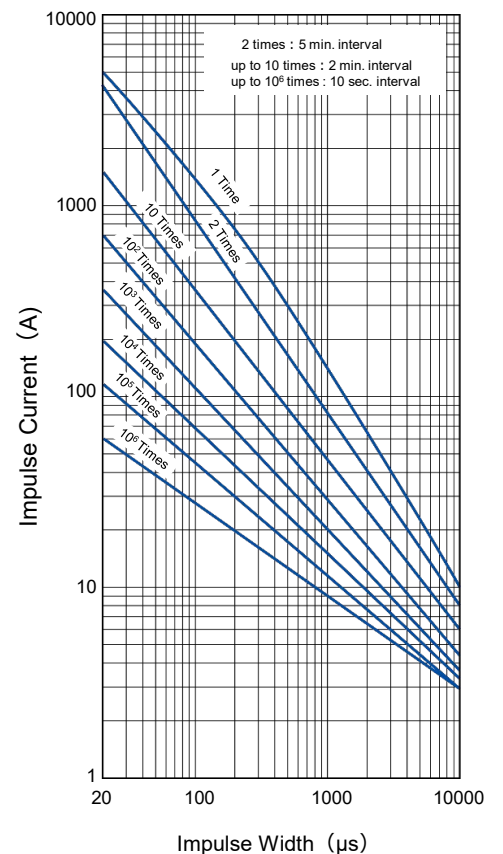

## Ratings and characteristics

●Operating temperature range : -40 to 85 °C

●Storage temperature range : -40 to 125 °C

Part No.	Varistor voltage at 1 mA	Maximum allowable voltage		Clamping voltage (max.) **Ip	Rated power	Maximum energy		Maximum peak current (8/20 μs)		Capacitance (max.) at 1 kHz
		ACrms (V)	DC (V)			(10/1000 μs)	(2 ms)	1 time	2 times	
	(V)	(V)	(V)	(W)	(J)	(J)	(A)	(A)	(pF)	
ERZE14A201	200(185 to 225)	130	170	340	1.0	140	100	10000	7000	1300
ERZE14A221	220(198 to 242)	140	180	360	1.0	155	110	10000	7000	1200
ERZE14A241	240(216 to 264)	150	200	395	1.0	168	120	10000	7000	1100
ERZE14A271	270(247 to 303)	175	225	455	1.0	190	135	10000	7000	1000
ERZE14A331	330(297 to 363)	210	270	545	1.0	228	160	10000	6500	900
ERZE14A361	360(324 to 396)	230	300	595	1.0	255	180	10000	6500	900
ERZE14A391	390(351 to 429)	250	320	650	1.0	275	195	10000	6500	800
ERZE14A431	430(387 to 473)	275	350	710	1.0	303	215	10000	6500	800
ERZE14A471	470(423 to 517)	300	385	775	1.0	350	250	10000	6500	750
ERZE14A511	510(459 to 561)	320	410	845	1.0	382	273	10000	6500	700
ERZE14A561	560(504 to 616)	350	450	930	1.0	382	273	10000	6500	700
ERZE14A621	620(558 to 682)	385	505	1025	1.0	382	273	7500	6500	650
ERZE14A681	680(612 to 748)	420	560	1120	1.0	382	273	7500	6500	600
ERZE14A751	750(675 to 825)	460	615	1240	1.0	420	300	7500	6500	530
ERZE14A821	820(738 to 902)	510	670	1355	1.0	460	325	7500	6500	500
ERZE14A911	910(819 to 1001)	550	745	1500	1.0	510	360	7500	6500	400
ERZE14A102	1000(900 to 1100)	625	825	1650	1.0	565	400	7500	6500	400
ERZE14A112	1100(990 to 1210)	680	895	1815	1.0	620	440	7500	6500	350

\*Ip Measuring current of clamping voltage : 100 A

## Dimensions in mm (not to scale)

Unit : mm

Part No.	D max.	T max.	F±1.0	A max.	L±1.0
ERZE14A201	16.5	5.2	10.0	20.0	2.1
ERZE14A221	16.5	5.3	10.0	20.0	2.2
ERZE14A241	16.5	5.4	10.0	20.0	2.3
ERZE14A271	16.5	5.6	10.0	20.0	2.5
ERZE14A331	16.5	5.9	10.0	20.0	2.8
ERZE14A361	16.5	6.1	10.0	20.0	3.0
ERZE14A391	16.5	6.2	10.0	20.0	3.1
ERZE14A431	16.5	6.4	10.0	20.0	3.3
ERZE14A471	16.5	6.6	10.0	20.0	3.5
ERZE14A511	16.5	6.8	10.0	20.0	3.7
ERZE14A561	16.5	7.2	10.0	20.0	4.0
ERZE14A621	17.5	7.5	10.0	20.5	4.4
ERZE14A681	17.5	7.8	10.0	20.5	4.7
ERZE14A751	17.5	8.2	10.0	20.5	5.1
ERZE14A821	17.5	8.5	10.0	20.5	5.4
ERZE14A911	17.5	9.0	10.0	20.5	5.9
ERZE14A102	17.5	9.5	10.0	20.5	6.4
ERZE14A112	17.5	10.1	10.0	20.5	7.2

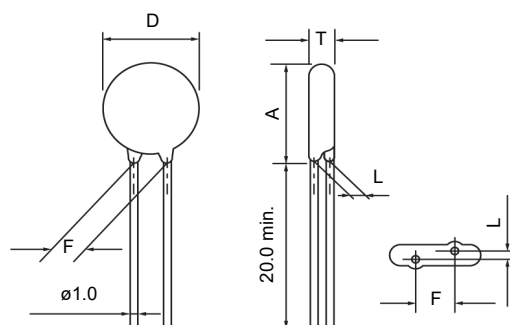

**Typical characteristics**

**Voltage vs. Current**

ERZE14A201 to ERZE14A511

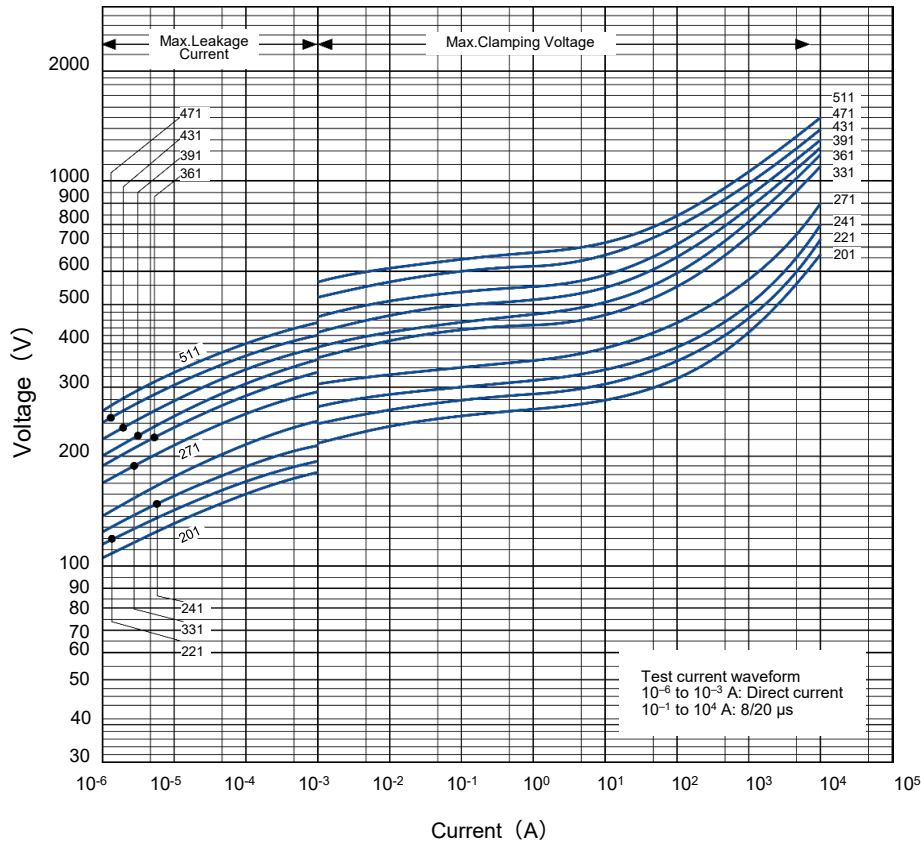

**Impulse Derating** (Relation between impulse width and impulse current multiple)

ERZE14A201 to ERZE14A511

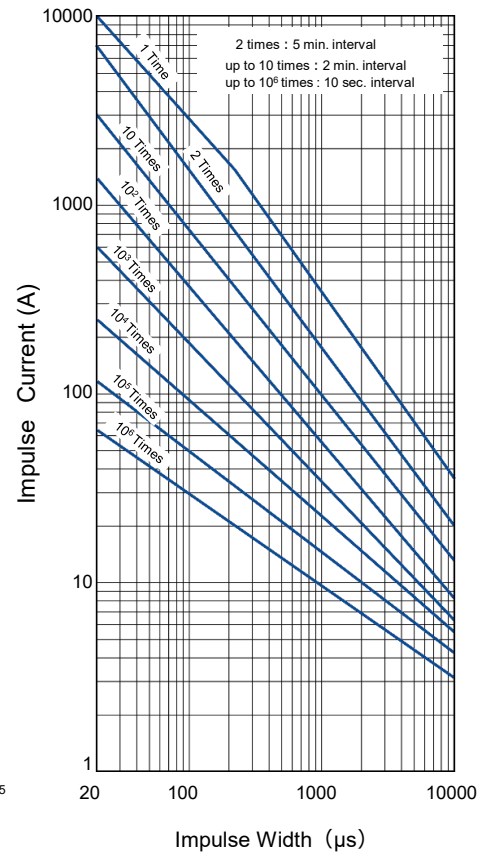

ERZE14A561 to ERZE14A112

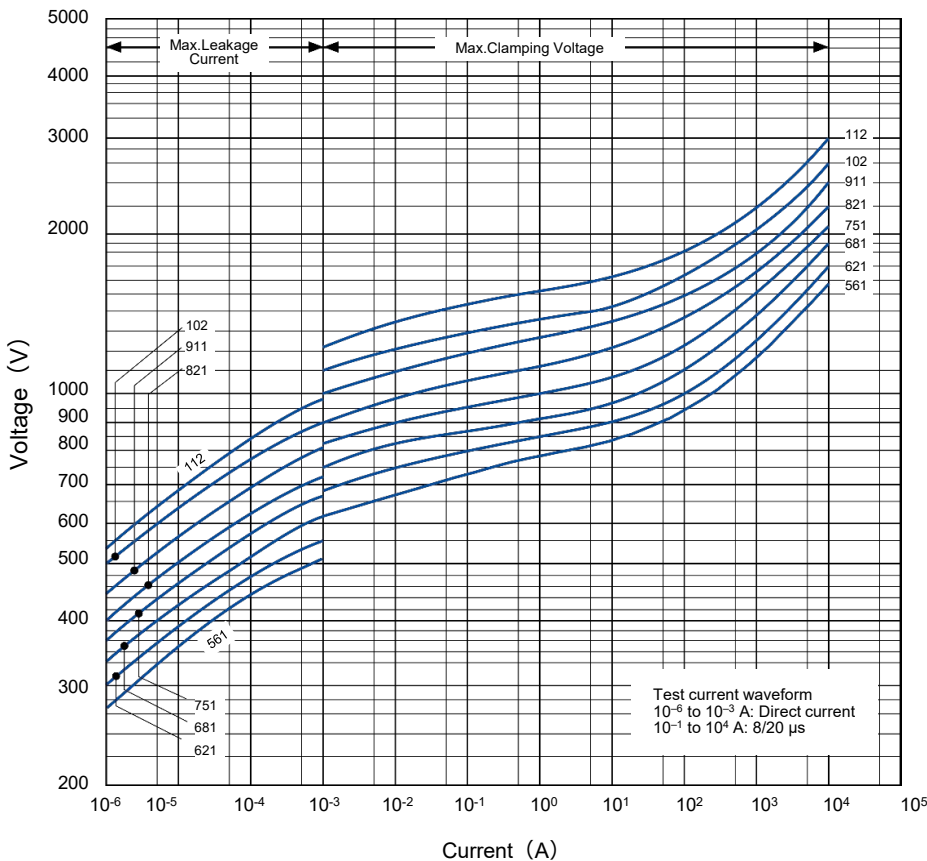

ERZE14A561 to ERZE14A112

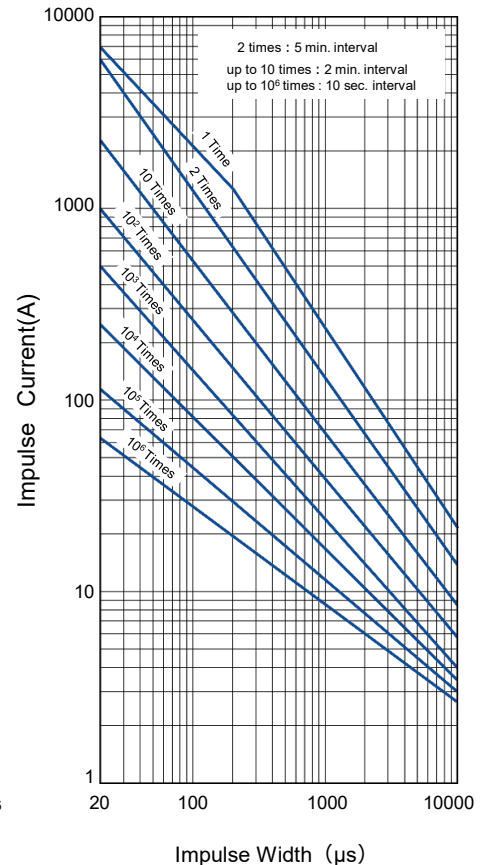

**Straight leads cut type (Bulk type)**

※ Ratings and characteristics is refer to bulk standard type.

**Dimensions in mm (not to scale)**

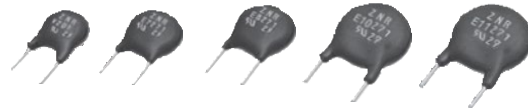
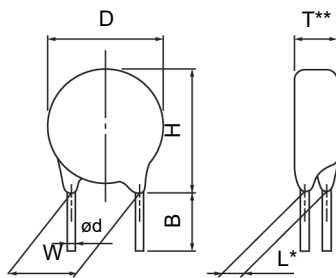

notes \* Dimension "L": Conforms to each individual specification.  
 \*\* Dimension "T": Conforms to each individual specification.

Unit : mm

Series	E5		E7		E8		E10		E11	
Varister Voltage	201 to 471	201 to 511	561	621	201 to 561	621 to 751	201 to 561	621 to 112	201 to 561	621 to 112
D	7.0 max.	9.0 max.	9.0 max.	10.0 max.	10.5 max.	11.5 max.	11.5 max.	12.5 max.	13.0 max.	14.0 max.
H	10.0 max.	12.5 max.	13.5 max.	13.5 max.	13.5 max.	14.5 max.	15.0 max.	16.0 max.	17.0 max.	18.0 max.
W	5.0±1.0	7.5±1.0	7.5±1.0	7.5±1.0	7.5±1.0	7.5±1.0	7.5±1.0	7.5±1.0	7.5±1.0	7.5±1.0
ød	0.60 +0.06 -0.05	0.80 +0.08 -0.05	0.80 +0.08 -0.05	0.80 +0.08 -0.05	0.80 +0.08 -0.05	0.80 +0.08 -0.05	0.80 +0.08 -0.05	0.80 +0.08 -0.05	0.80 +0.08 -0.05	0.80 +0.08 -0.05
B	4.0±1.0	4.0±1.0	4.0±1.0	4.0±1.0	4.0±1.0	4.0±1.0	4.0±1.0	4.0±1.0	4.0±1.0	4.0±1.0
Standard products part No.	ERZE05A□□□CS	ERZE07A□□□CS		ERZE08A□□□CS		ERZE10A□□□CS		ERZE11A□□□CS		

**Crimped leads cut type (Bulk Type)**

※ Ratings and characteristics is refer to bulk standard type.

**Dimensions in mm (not to scale)**

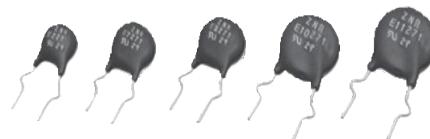
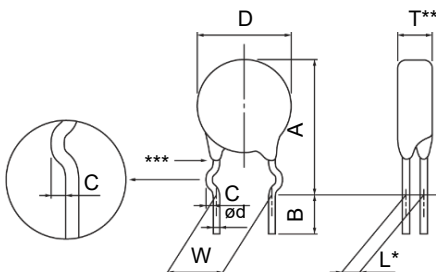

notes \* Dimension "L": Conforms to each individual specification.  
 \*\* Dimension "T": Conforms to each individual specification.  
 \*\*\* Resin extenysions : No resin below the center of the hook.

Unit : mm

Series	E5		E7		E8		E10			E11	
Varister Voltage	201 to 471	201 to 511	561	621	201 to 561	621 to 751	201 to 561	621 to 681	751 to 112	201 to 561	621 to 112
D	7.0 max.	9.0 max.	9.0 max.	10.0 max.	10.5 max.	11.5 max.	11.5 max.	12.5 max.	12.5 max.	13.0 max.	14.0 max.
A	13.0 max.	15.5 max.	16.5 max.	16.5 max.	17.0 max.	18.0 max.	18.0 max.	19.5 max..	20.5 max.	20.5 max.	21.5 max.
C	1.2±1.4	1.4±1.4	1.4±1.4	1.4±1.4	1.4±1.4	1.4±1.4	1.4±1.4	1.4±1.4	1.4±1.4	1.4±1.4	1.4±1.4
W	5.0±1.0	7.5±1.0	7.5±1.0	7.5±1.0	7.5±1.0	7.5±1.0	7.5±1.0	7.5±1.0	7.5±1.0	7.5±1.0	7.5±1.0
ød	0.60 +0.06 -0.05	0.80 +0.08 -0.05	0.80 +0.08 -0.05	0.80 +0.08 -0.05	0.80 +0.08 -0.05	0.80 +0.08 -0.05	0.80 +0.08 -0.05	0.80 +0.08 -0.05	0.80 +0.08 -0.05	0.80 +0.08 -0.05	0.80 +0.08 -0.05
B	4.0±1.0	4.0±1.0	4.0±1.0	4.0±1.0	4.0±1.0	4.0±1.0	4.0±1.0	4.0±1.0	4.0±1.0	4.0±1.0	4.0±1.0
Standard products part No.	ERZE05B□□□CS	ERZE07B□□□CS		ERZE08B□□□CS		ERZE10B□□□CS			ERZE11B□□□CS		

## D type / E series (Taping specifications)

### Taping specifications for automated assembly (Straight leads and taping)

※ Ratings and characteristics is refer to bulk standard type.

### Dimensions in mm (not to scale)

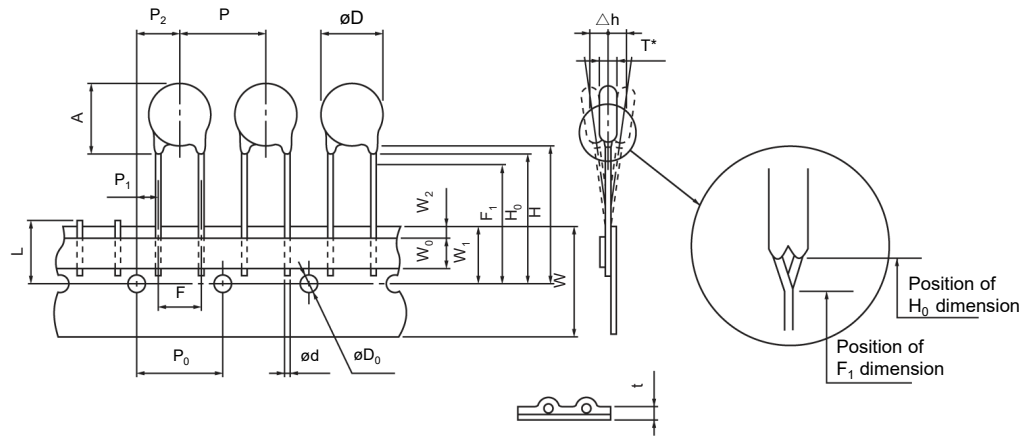

※ Dimension "T": Conforms to each individual specification.

Unit : mm

Series	E7				E8			E10			E11			
Symbol	201 to 471	201 to 271	331 to 551	561	621	201 to 221	241 to 561	621 to 751	201 to 221	241 to 561	621 to 112	201 to 221	241 to 561	621 to 112
Varistor Voltage	201 to 471	201 to 271	331 to 551	561	621	201 to 221	241 to 561	621 to 751	201 to 221	241 to 561	621 to 112	201 to 221	241 to 561	621 to 112
P	12.7±1.0	15.0±1.0	15.0±1.0	15.0±1.0	15.0±1.0	15.0±1.0	15.0±1.0	15.0±1.0	15.0±1.0	15.0±1.0	15.0±1.0	15.0±1.0	15.0±1.0	15.0±1.0
P <sub>0</sub>	12.7±0.3	15.0±0.3	15.0±0.3	15.0±0.3	15.0±0.3	15.0±0.3	15.0±0.3	15.0±0.3	15.0±0.3	15.0±0.3	15.0±0.3	15.0±0.3	15.0±0.3	15.0±0.3
P <sub>1</sub>	3.85±0.70	3.75±0.70	3.75±0.70	3.75±0.70	3.75±0.70	3.75±0.70	3.75±0.70	3.75±0.70	3.75±0.70	3.75±0.70	3.75±0.70	3.75±0.70	3.75±0.70	3.75±0.70
P <sub>2</sub>	6.36±1.30	7.5±1.3	7.5±1.3	7.5±1.3	7.5±1.3	7.5±1.3	7.5±1.3	7.5±1.3	7.5±1.3	7.5±1.3	7.5±1.3	7.5±1.3	7.5±1.3	7.5±1.3
ød	0.60 <sup>+0.06</sup> / <sub>-0.05</sub>	0.80 <sup>+0.08</sup> / <sub>-0.05</sub>	0.80 <sup>+0.08</sup> / <sub>-0.05</sub>	0.80 <sup>+0.08</sup> / <sub>-0.05</sub>	0.80 <sup>+0.08</sup> / <sub>-0.05</sub>	0.80 <sup>+0.08</sup> / <sub>-0.05</sub>	0.80 <sup>+0.08</sup> / <sub>-0.05</sub>	0.80 <sup>+0.08</sup> / <sub>-0.05</sub>	0.80 <sup>+0.08</sup> / <sub>-0.05</sub>	0.80 <sup>+0.08</sup> / <sub>-0.05</sub>	0.80 <sup>+0.08</sup> / <sub>-0.05</sub>	0.80 <sup>+0.08</sup> / <sub>-0.05</sub>	0.80 <sup>+0.08</sup> / <sub>-0.05</sub>	0.80 <sup>+0.08</sup> / <sub>-0.05</sub>
F	5.0±0.5	7.5±0.5	7.5±0.5	7.5±0.5	7.5±0.5	7.5±0.5	7.5±0.5	7.5±0.5	7.5±0.5	7.5±0.5	7.5±0.5	7.5±0.5	7.5±0.5	7.5±0.5
Δh	0±2	0±2	0±2	0±2	0±2	0±2	0±2	0±2	0±2	0±2	0±2	0±2	0±2	0±2
W	18.0 <sup>+1.0</sup> / <sub>-0.5</sub>	18.0 <sup>+1.0</sup> / <sub>-0.5</sub>	18.0 <sup>+1.0</sup> / <sub>-0.5</sub>	18.0 <sup>+1.0</sup> / <sub>-0.5</sub>	18.0 <sup>+1.0</sup> / <sub>-0.5</sub>	18.0 <sup>+1.0</sup> / <sub>-0.5</sub>	18.0 <sup>+1.0</sup> / <sub>-0.5</sub>	18.0 <sup>+1.0</sup> / <sub>-0.5</sub>	18.0 <sup>+1.0</sup> / <sub>-0.5</sub>	18.0 <sup>+1.0</sup> / <sub>-0.5</sub>	18.0 <sup>+1.0</sup> / <sub>-0.5</sub>	18.0 <sup>+1.0</sup> / <sub>-0.5</sub>	18.0 <sup>+1.0</sup> / <sub>-0.5</sub>	18.0 <sup>+1.0</sup> / <sub>-0.5</sub>
W <sub>0</sub>	5.0 min.	5.0 min.	5.0 min.	5.0 min.	5.0 min.	5.0 min.	5.0 min.	5.0 min.	5.0 min.	5.0 min.	5.0 min.	5.0 min.	5.0 min.	5.0 min.
W <sub>1</sub>	9.0±0.5	9.0±0.5	9.0±0.5	9.0±0.5	9.0±0.5	9.0±0.5	9.0±0.5	9.0±0.5	9.0±0.5	9.0±0.5	9.0±0.5	9.0±0.5	9.0±0.5	9.0±0.5
W <sub>2</sub>	3.0 max.	3.0 max.	3.0 max.	3.0 max.	3.0 max.	3.0 max.	3.0 max.	3.0 max.	3.0 max.	3.0 max.	3.0 max.	3.0 max.	3.0 max.	3.0 max.
H	Approx. 22	Approx. 22	Approx. 22	Approx. 22	Approx. 22	Approx. 22	Approx. 22	Approx. 22	Approx. 22	Approx. 22	Approx. 22	Approx. 22	Approx. 22	Approx. 22
H <sub>0</sub>	17.0±0.5	18.0 <sup>+2.0</sup> / <sub>0</sub>	---	---	---	18.0 <sup>+2.0</sup> / <sub>0</sub>	---	---	18.0 <sup>+2.0</sup> / <sub>0</sub>	---	---	18.0 <sup>+2.0</sup> / <sub>0</sub>	---	---
F <sub>1</sub>	---	---	16.0 <sup>+0.75</sup> / <sub>-0.50</sub>	16.0 <sup>+0.75</sup> / <sub>-0.50</sub>	16.0 <sup>+0.75</sup> / <sub>-0.50</sub>	---	16.0 <sup>+0.75</sup> / <sub>-0.50</sub>	16.0 <sup>+0.75</sup> / <sub>-0.50</sub>	---	16.0 <sup>+0.75</sup> / <sub>-0.50</sub>	16.0 <sup>+0.75</sup> / <sub>-0.50</sub>	---	16.0 <sup>+0.75</sup> / <sub>-0.50</sub>	16.0 <sup>+0.75</sup> / <sub>-0.50</sub>
øD <sub>0</sub>	ø4.0±0.2	ø4.0±0.2	ø4.0±0.2	ø4.0±0.2	ø4.0±0.2	ø4.0±0.2	ø4.0±0.2	ø4.0±0.2	ø4.0±0.2	ø4.0±0.2	ø4.0±0.2	ø4.0±0.2	ø4.0±0.2	ø4.0±0.2
t	0.6±0.3	0.6±0.3	0.6±0.3	0.6±0.3	0.6±0.3	0.6±0.3	0.6±0.3	0.6±0.3	0.6±0.3	0.6±0.3	0.6±0.3	0.6±0.3	0.6±0.3	0.6±0.3
L	11.0 max.	11.0 max.	11.0 max.	11.0 max.	11.0 max.	11.0 max.	11.0 max.	11.0 max.	11.0 max.	11.0 max.	11.0 max.	11.0 max.	11.0 max.	11.0 max.
øD	7.0 max.	9.0 max.	9.0 max.	9.0 max.	10.0 max.	10.5 max.	10.5 max.	11.5 max.	11.5 max.	11.5 max.	12.5 max.	13.0 max.	13.0 max.	14.0 max.
A	10.0 max.	12.5 max.	12.5 max.	13.5 max.	13.5 max.	13.5 max.	13.5 max.	14.5 max.	15.0 max.	15.0 max.	16.0 max.	17.0 max.	17.0 max.	18.0 max.
Standard products part	ERZE05E □□	ERZE07E □□□□				ERZE08E □□□□			ERZE10E □□□□			ERZE11E □□□□		

## D type / E series (Taping specifications)

### Taping specifications for automated assembly (Crimped leads and taping)

※ Ratings and characteristics is refer to bulk standard type.

### Dimensions in mm (not to scale)

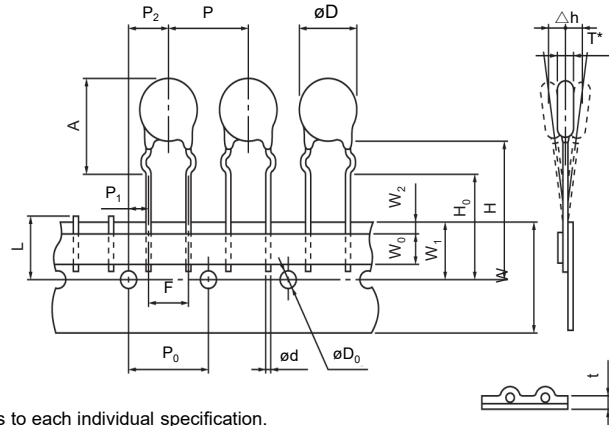

\* Dimension "T": Conforms to each individual specification.

Unit : mm

Series Symbol	E5		E7		E8			E10			E11		
	201 to 471	201 to 551	561	621	201 to 221	241 to 561	621 to 751	201 to 561	621 to 681	751 to 112	201 to 221	241 to 561	621 to 112
P	12.7±1.0	15.0±1.0	15.0±1.0	15.0±1.0	15.0±1.0	15.0±1.0	15.0±1.0	15.0±1.0	15.0±1.0	15.0±1.0	15.0±1.0	15.0±1.0	15.0±1.0
P <sub>0</sub>	12.7±0.3	15.0±0.3	15.0±0.3	15.0±0.3	15.0±0.3	15.0±0.3	15.0±0.3	15.0±0.3	15.0±0.3	15.0±0.3	15.0±0.3	15.0±0.3	15.0±0.3
P <sub>1</sub>	3.85±0.70	3.75±0.70	3.75±0.70	3.75±0.70	3.75±0.70	3.75±0.70	3.75±0.70	3.75±0.70	3.75±0.70	3.75±0.70	3.75±0.70	3.75±0.70	3.75±0.70
P <sub>2</sub>	6.36±1.30	7.5±1.3	7.5±1.3	7.5±1.3	7.5±1.3	7.5±1.3	7.5±1.3	7.5±1.3	7.5±1.3	7.5±1.3	7.5±1.3	7.5±1.3	7.5±1.3
ø d	0.60 <sup>+0.06</sup> / <sub>-0.05</sub>	0.80 <sup>+0.08</sup> / <sub>-0.05</sub>	0.80 <sup>+0.08</sup> / <sub>-0.05</sub>	0.80 <sup>+0.08</sup> / <sub>-0.05</sub>	0.80 <sup>+0.08</sup> / <sub>-0.05</sub>	0.80 <sup>+0.08</sup> / <sub>-0.05</sub>	0.80 <sup>+0.08</sup> / <sub>-0.05</sub>	0.80 <sup>+0.08</sup> / <sub>-0.05</sub>	0.80 <sup>+0.08</sup> / <sub>-0.05</sub>	0.80 <sup>+0.08</sup> / <sub>-0.05</sub>	0.80 <sup>+0.08</sup> / <sub>-0.05</sub>	0.80 <sup>+0.08</sup> / <sub>-0.05</sub>	0.80 <sup>+0.08</sup> / <sub>-0.05</sub>
F	5.0±0.5	7.5±0.5	7.5±0.5	7.5±0.5	7.5±0.5	7.5±0.5	7.5±0.5	7.5±0.5	7.5±0.5	7.5±0.5	7.5±0.5	7.5±0.5	7.5±0.5
Δ h	0±2	0±2	0±2	0±2	0±2	0±2	0±2	0±2	0±2	0±2	0±2	0±2	0±2
W	18.0 <sup>+1.0</sup> / <sub>-0.5</sub>	18.0 <sup>+1.0</sup> / <sub>-0.5</sub>	18.0 <sup>+1.0</sup> / <sub>-0.5</sub>	18.0 <sup>+1.0</sup> / <sub>-0.5</sub>	18.0 <sup>+1.0</sup> / <sub>-0.5</sub>	18.0 <sup>+1.0</sup> / <sub>-0.5</sub>	18.0 <sup>+1.0</sup> / <sub>-0.5</sub>	18.0 <sup>+1.0</sup> / <sub>-0.5</sub>	18.0 <sup>+1.0</sup> / <sub>-0.5</sub>	18.0 <sup>+1.0</sup> / <sub>-0.5</sub>	18.0 <sup>+1.0</sup> / <sub>-0.5</sub>	18.0 <sup>+1.0</sup> / <sub>-0.5</sub>	18.0 <sup>+1.0</sup> / <sub>-0.5</sub>
W <sub>0</sub>	5.0 min.	5.0 min.	5.0 min.	5.0 min.	5.0 min.	5.0 min.	5.0 min.	5.0 min.	5.0 min.	5.0 min.	5.0 min.	5.0 min.	5.0 min.
W <sub>1</sub>	9.0±0.5	9.0±0.5	9.0±0.5	9.0±0.5	9.0±0.5	9.0±0.5	9.0±0.5	9.0±0.5	9.0±0.5	9.0±0.5	9.0±0.5	9.0±0.5	9.0±0.5
W <sub>2</sub>	3.0 max.	3.0 max.	3.0 max.	3.0 max.	3.0 max.	3.0 max.	3.0 max.	3.0 max.	3.0 max.	3.0 max.	3.0 max.	3.0 max.	3.0 max.
H	Approx. 22	Approx. 22	Approx. 22	Approx. 22	Approx. 22	Approx. 22	Approx. 22	Approx. 22	Approx. 22	Approx. 22	Approx. 22	Approx. 22	Approx. 22
H <sub>0</sub>	17.0±0.5	16.0±0.5	16.0±0.5	16.0±0.5	16.0±0.5	16.0±0.5	16.0±0.5	16.0±0.5	16.0±0.5	16.0±0.5	16.0±0.5	16.0±0.5	16.0±0.5
ø D <sub>0</sub>	ø4.0±0.2	ø4.0±0.2	ø4.0±0.2	ø4.0±0.2	ø4.0±0.2	ø4.0±0.2	ø4.0±0.2	ø4.0±0.2	ø4.0±0.2	ø4.0±0.2	ø4.0±0.2	ø4.0±0.2	ø4.0±0.2
t	0.6±0.3	0.6±0.3	0.6±0.3	0.6±0.3	0.6±0.3	0.6±0.3	0.6±0.3	0.6±0.3	0.6±0.3	0.6±0.3	0.6±0.3	0.6±0.3	0.6±0.3
L	11.0 max.	11.0 max.	11.0 max.	11.0 max.	11.0 max.	11.0 max.	11.0 max.	11.0 max.	11.0 max.	11.0 max.	11.0 max.	11.0 max.	11.0 max.
ø D	7.0 max.	9.0 max.	9.0 max.	10.0 max.	10.5 max.	10.5 max.	11.5 max.	11.5 max.	12.5 max.	12.5 max.	13.0 max.	13.0 max.	14.0 max.
A	13.0 max.	15.5 max.	16.5 max.	16.5 max.	17.0 max.	17.0 max.	18.0 max.	18.0 max.	19.5 max.	20.5 max.	20.5 max.	20.5 max.	21.5 max.
Standard products part	ERZE05F□□□	ERZE07F□□□		ERZE08F□□□			ERZE10F□□□			ERZE11F□□□			

## Application note for safety standards

- Approvals products lists in "Reference Guide to Standard Products."
- UL and VDE : Registered in "Type name", it isn't registered in "Panasonic Part No."
- CQC : Registered in "Panasonic Part No."
- "Rated Voltages" are specified for UL recognized components in list shown below.

## The AC rated voltage and maximum allowable voltage

Type name	Maximum allowable voltage		Rated voltage (Vrms)
	ACrms (V)	DC (V)	UL1449
E*201	130	170	118
E*221	140	180	127
E*241	150	200	136
E*271	175	225	159
E*331	210	270	189
E*361	230	300	209
E*391	250	320	227
E*431	275	350	250
E*471	300	385	272
E*511	320	410	291
E*561	350	450	320
E*621	385	505	350
E*681	420	560	381
E*751	460	615	418
E*821	510	670	463
E*911	550	745	500
E*102	625	825	568
E*112	680	895	600

\* : 5 Series is blank, 7 series is 7, 8 series is 8, 10 series is 10, 11 series is 11, 14 series is 14

**Explanation of the contents**

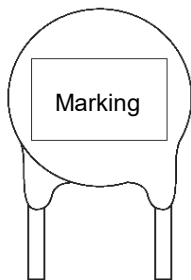

Mark	Explanation of the content	
E*□□□	Abbreviation of part No. (Type Name)	[ □□□ Nominal varistor volage ]
○	Factory identification mark	None : Japan Q : Indonesia
◆ <sup>*1</sup>	Year code	2019 : 9, 2020 : K, 2021 : A 2022 : B, 2023 : C, 2024 : D
◇	Monthly code	Jan : 1 to Sep : 9, Oct. : 0, Nov. : N, Dec. : D
UL	UL Recognized components mark	

\* : 5 series is blank, 7 series is 7, 8 series is 8, 10 series is 10, 11 series is 11, 14 series is 14

\*1: If the 10's digit of a Christian year is an even year, as an end abbreviation, an alphabetic character is used.

1 : A, 2 : B, 3 : C, 4 : D, 5 : E, 6 : F, 7 : G, 8 : H, 9 : J, 0 : K

If the 10's digit of a Christian year is an odd year, as an end abbreviation, a number is used.

**Marking contents**

Series (Example) Varistor voltage	5 (ERZE05A□□□)	7 (ERZE07A□□□)	8 (ERZE08A□□□)	10 (ERZE10A□□□)	11 (ERZE11A□□□)	14 (ERZE14A□□□)
201 or more	ZNR E□□□ UL ○ ◆ ◆	ZNR E7□□□ UL ○ ◆ ◆	ZNR E8□□□ UL ○ ◆ ◆	ZNR E10□□□ UL ○ ◆ ◆	ZNR E11□□□ UL ○ ◆ ◆	ZNR E14□□□ UL ○ ◆ ◆

**Performance characteristics**

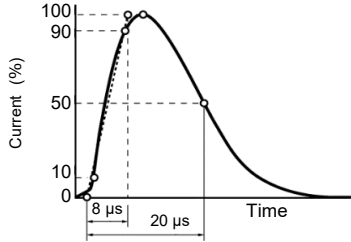
Characteristics		Test methods / description	Specifications																										
Standard test condition		Electrical measurements (initial/after tests) shall be conducted at temperature of 5 to 35°C, relative humidity of maximum 85 %.	—																										
Electrical	Varistor voltage	The voltage between two terminals with the specified measuring current 1mA DC applied is called $V_1$ or $V_{1mA}$ . The measurement shall be made as fast as possible to avoid heat affection.	To meet the specified value.																										
	Maximum allowable voltage	The maximum sinusoidal RMS voltage or maximum DC voltage that can be applied continuously.																											
	Clamping voltage	The maximum voltage between two terminals with the specified standard impulse current (8/20 $\mu$ s) illustrated below applied.  																											
	Rated power	The power that can be applied in the specified ambient temperature.																											
	Maximum energy	The maximum energy within the varistor voltage change of $\pm 10$ % when a single impulse current of 2 ms or 10/1000 $\mu$ s is applied.																											
	Maximum peak current (Withstanding surge current)	2 times		The maximum current within the varistor voltage change of $\pm 10$ % when a standard impulse current of 8/20 $\mu$ s is applied two times with an interval of 5 minutes.																									
		1 time		The maximum current within the varistor voltage change of $\pm 10$ % with a single standard impulse current of 8/20 $\mu$ s is applied.																									
	Temperature coefficient of varistor voltage	$\frac{V_{1mA} \text{ at } 85^\circ\text{C} - V_{1mA} \text{ at } 25^\circ\text{C}}{V_{1mA} \text{ at } 25^\circ\text{C}} \times \frac{1}{60} 100(\%/^\circ\text{C})$		0 to -0.05 %/ °C max.																									
	Capacitance	Capacitance shall be measured at 1 kHz $\pm 10$ %, 1 Vrms max. (1 MHz $\pm 10$ % below 100 pF), 0 V bias and 20 $\pm 2$ °C.		To meet the specified value.																									
	Withstanding voltage (Body insulation)	AC 1500 Vrms shall be applied between both terminals of the specimen connected together and metal foil closely wrapped round its body for 1 minute.		No breakdown																									
Impulse life	The change of VC shall be measured after the impulse current listed below is applied 10000 or 100000 times continuously with the interval of 10 seconds at room temperature.  <table border="1" data-bbox="411 1556 1193 1955"> <thead> <tr> <th>Item</th> <th>Impulse Life( I )</th> <th>Impulse Life( II )</th> </tr> </thead> <tbody> <tr> <td>Times</td> <td><math>\times 10^4</math> Times</td> <td><math>\times 10^5</math> Times</td> </tr> <tr> <td>Part No.</td> <td colspan="2">Impulse Current</td> </tr> <tr> <td>ERZE05A201 to ERZE05A471</td> <td>50 A (8/20 <math>\mu</math>s)</td> <td>35 A (8/20 <math>\mu</math>s)</td> </tr> <tr> <td>ERZE07A201 to ERZE07A471</td> <td>100 A (8/20 <math>\mu</math>s)</td> <td>70 A (8/20 <math>\mu</math>s)</td> </tr> <tr> <td>ERZE08A201 to ERZE08A751</td> <td>150 A (8/20 <math>\mu</math>s)</td> <td>85 A (8/20 <math>\mu</math>s)</td> </tr> <tr> <td>ERZE10A201 to ERZE10A112</td> <td>170 A (8/20 <math>\mu</math>s)</td> <td>90 A (8/20 <math>\mu</math>s)</td> </tr> <tr> <td>ERZE11A201 to ERZE11A112</td> <td>200 A (8/20 <math>\mu</math>s)</td> <td>110 A (8/20 <math>\mu</math>s)</td> </tr> <tr> <td>ERZE14A201 to ERZE14A112</td> <td>250 A (8/20 <math>\mu</math>s)</td> <td>120 A (8/20 <math>\mu</math>s)</td> </tr> </tbody> </table>	Item	Impulse Life( I )	Impulse Life( II )	Times	$\times 10^4$ Times	$\times 10^5$ Times	Part No.	Impulse Current		ERZE05A201 to ERZE05A471	50 A (8/20 $\mu$ s)	35 A (8/20 $\mu$ s)	ERZE07A201 to ERZE07A471	100 A (8/20 $\mu$ s)	70 A (8/20 $\mu$ s)	ERZE08A201 to ERZE08A751	150 A (8/20 $\mu$ s)	85 A (8/20 $\mu$ s)	ERZE10A201 to ERZE10A112	170 A (8/20 $\mu$ s)	90 A (8/20 $\mu$ s)	ERZE11A201 to ERZE11A112	200 A (8/20 $\mu$ s)	110 A (8/20 $\mu$ s)	ERZE14A201 to ERZE14A112	250 A (8/20 $\mu$ s)	120 A (8/20 $\mu$ s)	$\Delta V_{1mA}/V_{1mA} \leq 0 \text{ to } +20\%$
Item	Impulse Life( I )	Impulse Life( II )																											
Times	$\times 10^4$ Times	$\times 10^5$ Times																											
Part No.	Impulse Current																												
ERZE05A201 to ERZE05A471	50 A (8/20 $\mu$ s)	35 A (8/20 $\mu$ s)																											
ERZE07A201 to ERZE07A471	100 A (8/20 $\mu$ s)	70 A (8/20 $\mu$ s)																											
ERZE08A201 to ERZE08A751	150 A (8/20 $\mu$ s)	85 A (8/20 $\mu$ s)																											
ERZE10A201 to ERZE10A112	170 A (8/20 $\mu$ s)	90 A (8/20 $\mu$ s)																											
ERZE11A201 to ERZE11A112	200 A (8/20 $\mu$ s)	110 A (8/20 $\mu$ s)																											
ERZE14A201 to ERZE14A112	250 A (8/20 $\mu$ s)	120 A (8/20 $\mu$ s)																											

## Performance characteristics

Characteristics		Test methods / description		Specifications													
Mechanical	Robustness of terminations (Tensile)	After gradually applying the force specified below and keeping the unit fixed for 10 seconds, the terminal shall be visually examined for any damage.		No remarkable mechanical damage													
		<u>Terminal diameter</u> ø0.6 mm, ø0.8 mm ø1.0 mm	<u>Force</u> 9.8 N 19.6 N														
	Robustness of terminations (Bending)	The unit shall be secured with its terminal kept vertical and the force specified below shall be applied in the axial direction. The terminal shall gradually be bent by 90 ° in one direction, then 90 ° in the opposite direction, and again back to the original position. The damage of the terminal shall be visually examined.															
		<u>Terminal diameter</u> ø0.6 mm, ø0.8 mm ø1.0 mm	<u>Force</u> 4.9 N 9.8 N														
	Vibration	After repeatedly applying a single harmonic vibration (amplitude: 0.75 mm, double amplitude: 1.5 mm) with 1 minute vibration frequency cycles (10 Hz to 55 Hz to 10 Hz) to each of three perpendicular directions for 2 hours. Thereafter, the unit shall be visually examined.															
Solderability	After dipping the terminals to a depth of approximately 3 mm from the body in a soldering bath of 235±5°C for 2±0.5 seconds, the terminal shall be visually examined.		Approximately 95 % of the terminals shall be covered with new solder uniformly.														
Resistance to soldering heat	After each lead shall be dipped into a solder bath having a temperature of 260±5°C to a point 2.0 to 2.5 mm from the body of the unit, using shielding board (t=1.5 mm), be held there for 10±1 s and then be stored at room temperature and normal humidity for 1 hour or over. The change of VCmA and mechanical damages shall be examined.		$\Delta V1mA/V1mA \leq \pm 5 \%$														
Environmental	High temperature storage/Dry heat	The specimen shall be subjected to 125±2°C for 1000 hours in a thermostatic bath without load and then stored at room temperature and normal humidity for 1 hour or over. Thereafter, the change of VCmA shall be measured.		$\Delta V1mA/V1mA \leq \pm 5 \%$													
	Humidity	The specimen shall be subjected to 40±2°C, 90 to 95 % RH for 1000 hours without load and then stored at room temperature and normal humidity for 1 hour or over. Thereafter, the change of VCmA shall be measured.		$\Delta V1mA/V1mA \leq \pm 5 \%$													
	Temperature cycle	The temperature cycle shown below shall be repeated five cycles and then stored at room temperature and normal humidity for 1 hour or over. The change of VCmA and mechanical damage shall be examined.		$\Delta V1mA/V1mA \leq \pm 5 \%$ No remarkable mechanical damage													
		<table border="1"> <thead> <tr> <th>Step</th> <th>Temperature (°C)</th> <th>Period (minutes)</th> </tr> </thead> <tbody> <tr> <td>1</td> <td>-40±3</td> <td>30±3</td> </tr> <tr> <td>2</td> <td>Room temperature</td> <td>15±3</td> </tr> <tr> <td>3</td> <td>125±2</td> <td>30±3</td> </tr> <tr> <td>4</td> <td>Room temperature</td> <td>15±3</td> </tr> </tbody> </table>	Step		Temperature (°C)	Period (minutes)	1	-40±3	30±3	2	Room temperature	15±3	3	125±2	30±3	4	Room temperature
	Step	Temperature (°C)	Period (minutes)														
1	-40±3	30±3															
2	Room temperature	15±3															
3	125±2	30±3															
4	Room temperature	15±3															
High temperature load/Dry heat load	After being continuously applied the Maximum Allowable Voltage at 85±2°C for 1000 hours, the specimen shall be stored at room temperature and normal humidity for 1 hour or over. Thereafter, the change of VCmA shall be measured.		$\Delta V1mA/V1mA \leq \pm 10 \%$														
Damp heat load/Humidity load	The specimen shall be subjected to 40±2°C, 90 to 95 % RH and the Maximum Allowable Voltage for 1000 hours and then stored at room temperature and normal humidity for 1 hour or over. Thereafter, the change of VCmA shall be measured.																
Low temperature storage/Cold	The specimen shall be subjected to -40±2°C without load for 1000 hours and then stored at room temperature and normal humidity for 1 hour or over. Thereafter, the change of VCmA shall be measured.		$\Delta V1mA/V1mA \leq \pm 5 \%$														

## Minimum quantity / Packing unit

Product	Series / Type	Part number	Minimum quantity / Packing unit	Packing quantity in carton	Carton (about) L×W×H (mm)
Varistors (ZNR Surge Absorber)	D type E series	ERZE05A201 to 471	100	10000	210×340×180
		ERZE07A201 to 391	50	3000	210×340×130
		ERZE07A431 to 621	50	3000	210×340×150
		ERZE08A201 to 331	50	3000	210×340×110
		ERZE08A361 to 511	50	3000	210×340×110
		ERZE08A561 to 751	50	2000	210×340×110
		ERZE10A201 to 241	50	3000	210×340×110
		ERZE10A271 to 431	50	3000	210×340×110
		ERZE10A471 to 112	50	2000	210×340×110
		ERZE11A201 to 361	50	3000	210×340×110
		ERZE11A391 to 561	50	2000	210×340×110
		ERZE11A621 to 112	50	1000	210×340×110
		ERZE14A201 to 221	50	2000	210×340×110
		ERZE14A241 to 431	50	2000	210×340×110
		ERZE14A471 to 112	50	1000	210×340×110
		ERZE05A(B)201CS to 471CS	100	10000	210×340×180
		ERZE07A(B)201CS to 391CS	100	4000	210×340×110
		ERZE07A(B)431CS to 621CS	50	4000	210×340×110
		ERZE08A(B)201CS to 331CS	100	4000	210×340×110
		ERZE08A(B)361CS to 511CS	50	4000	210×340×110
		ERZE08A(B)561CS to 751CS	50	3000	210×340×110
		ERZE10A(B)201CS to 241CS	100	4000	210×340×110
		ERZE10A(B)271CS to 431CS	50	4000	210×340×110
		ERZE10A(B)471CS to 112CS	50	3000	210×340×110
		ERZE11A(B)201CS to 361CS	50	3000	210×340×110
		ERZE11A(B)391CS to 561CS	50	2000	210×340×110
		ERZE11A(B)621CS to 112CS	50	2000	210×340×110
		ERZE05E201 to 471	1000	10000	400×360×260
		ERZE07E201 to 271	1000	10000	400×360×260
		ERZE07E331 to 471	1000	10000	470×360×260
		ERZE07E511 to 621	500	5000	400×360×260
		ERZE08E201 to 271	1000	5000	360×310×320
		ERZE08E331 to 431	1000	5000	360×310×320
		ERZE08E471 to 511	1000	5000	360×310×320
		ERZE08E561 to 751	500	2500	360×270×320
		ERZE10E201 to 241	1000	5000	360×310×320
		ERZE10E271 to 471	1000	5000	360×310×320
		ERZE10E511 to 561	1000	5000	360×310×320
		ERZE10E621 to 112	500	2500	360×270×320
		ERZE11E201 to 271	1000	5000	360×310×320
		ERZE11E331 to 511	1000	5000	360×310×320
		ERZE11E561 to 112	500	2500	360×270×320
		ERZE05F201 to 471	1000	10000	400×360×260
		ERZE07F201 to 271	1000	10000	400×360×260
		ERZE07F331 to 471	1000	10000	470×360×260
		ERZE07F511 to 621	500	5000	400×360×260
		ERZE08F201 to 271	1000	5000	360×310×320
		ERZE08F331 to 431	1000	5000	360×310×320
ERZE08F471 to 511	1000	5000	360×310×320		
ERZE08F561 to 751	500	2500	360×270×320		
ERZE10F201 to 241	1000	5000	360×310×320		
ERZE10F271 to 471	1000	5000	360×310×320		
ERZE10F511 to 561	1000	5000	360×310×320		
ERZE10F621 to 112	500	2500	360×270×320		
ERZE11F201 to 271	1000	5000	360×310×320		
ERZE11F331 to 511	1000	5000	360×310×320		
ERZE11F561 to 112	500	2500	360×270×320		

Part No., quantity and country of origin are designated on outer packages in English.

※Please contact local sales office about packing specifications.

## Safety and Legal Matters to Be Observed

### Product specifications and applications

- Please be advised that this product and product specifications are subject to change without notice for improvement purposes. Therefore, please request and confirm the latest delivery specifications that explain the specifications in detail before the final design, or purchase or use of the product, regardless of the application. In addition, do not use this product in any way that deviates from the contents of the company's delivery specifications.
- Unless otherwise specified in this catalog or the product specifications, this product is intended for use in general electronic equipment (AV products, home appliances, commercial equipment, office equipment, information and communication equipment, etc.).  
When this product is used for the following special cases, the specification document suited to each application shall be signed/sealed (with Panasonic Industry and the user) in advance..These include applications requiring special quality and reliability, wherein their failures or malfunctions may directly threaten human life or cause harm to the human body (e.g.: space/aircraft equipment, transportation/traffic equipment, combustion equipment, medical equipment, disaster prevention/crime prevention equipment, safety equipment, etc.).

### Safety design and product evaluation

- Please ensure safety through protection circuits, redundant circuits, etc., in the customer's system design so that a defect in our company's product will not endanger human life or cause other serious damage.
- This catalog shows the quality and performance of individual parts. The durability of parts varies depending on the usage environment and conditions. Therefore, please ensure to evaluate and confirm the state of each part after it has been mounted in your product in the actual operating environment before use.  
If you have any doubts about the safety of this product, then please notify us immediately, and be sure to conduct a technical review including the above protection circuits and redundant circuits at your company.

### Laws / Regulations / Intellectual property

- The transportation of dangerous goods as designated by UN numbers, UN classifications, etc., does not apply to this product. In addition, when exporting products, product specifications, and technical information described in this catalog, please comply with the laws and regulations of the countries to which the products are exported, especially those concerning security export control.
- Each model of this product complies with the RoHS Directive (Restriction of the use of hazardous substances in electrical and electronic equipment) (2011/65/EU and (EU) 2015/863). The date of compliance with the RoHS Directive and REACH Regulation varies depending on the product model.  
Further, if you are using product models in stock and are not sure whether or not they comply with the RoHS Directive or REACH Regulation, please contact us by selecting "Sales Inquiry" from the inquiry form.
- During the manufacturing process of this product and any of its components and materials to be used, Panasonic Industry does not intentionally use ozone-depleting substances stipulated in the Montreal Protocol and specific bromine-based flame retardants such as PBBs (Poly-Brominated Biphenyls) / PBDEs (Poly-Brominated Diphenyl Ethers). In addition, the materials used in this product are all listed as existing chemical substances based on the Act on the Regulation of Manufacture and Evaluation of Chemical Substances.
- With regard to the disposal of this product, please confirm the disposal method in each country and region where it is incorporated into your company's product and used.
- The technical information contained in this catalog is intended to show only typical operation and application circuit examples of this product. This catalog does not guarantee that such information does not infringe upon the intellectual property rights of Panasonic Industry or any third party, nor imply that the license of such rights has been granted.
- Design, materials, or process related to technical owned by Panasonic Industry are subject to change without notice.

**Panasonic Industry will assume no liability whatsoever if the use of our company's products deviates from the contents of this catalog or does not comply with the precautions. Please be advised of these restrictions.**

## Matters to Be Observed When Using This Product

### (D-type : E series)

#### Safety measures

An abnormal state of the D-type / E series varistor (ZNR surge absorber, hereinafter "the product" or "the surge absorber") that results from a problem with service conditions (materials used, the surrounding environment, power conditions, circuit conditions, etc.) may cause a fire accident, electric shock accident, burn accident, or product failure. Matters to note when handling this product will hereinafter be described. What is described below should be checked sufficiently before the product is used.

##### ■ Confirming rated capabilities

Use the surge absorber within the range of its rated capabilities. Each type of surge absorber has specified rated capabilities including a maximum allowable circuit voltage, a surge current tolerance, an energy tolerance, an impulse lifespan (surge lifespan), average pulse power, and a service temperature. Using the surge absorber under severe service conditions that are beyond the rated capabilities causes degraded performance of the surge absorber or destruction of a circuit element, which may lead to smoke generation, ignition, etc.

##### ■ Take the following measures in order to avoid an accident caused by expected phenomenon.

- (1) Destruction of the surge absorber may scatter its fractured pieces around. To protect other elements from these pieces, set product in a case or shield it with a cover.
- (2) Do not place the surge absorber near combustible materials (vinyl cable, resin mold, etc.). If avoiding the vicinity of combustible materials is difficult, protect the combustible material with an incombustible cover.

##### (3) Surge absorber placed between lines

When the surge absorber is placed between lines, connect a normal type current fuse in series with the surge absorber.

\* See "Current fuse" in the "Circuit design and circuit board design" section.

##### (4) Surge absorber placed between a line and the ground

- ① When the surge absorber is placed between a line and the ground, even if the surge absorber short-circuits, ground resistance will remain in the section between the line and the ground, leaving a possibility that the current fuse won't blow, in which case the outer sheath resin of the surge absorber may generate smoke or ignite due to current flow. To prevent such a case, place an earth leakage breaker in a location closer to the power supply than the surge absorber. When not using an earth leakage breaker, use a current fuse and temperature fuse in series with each other.

\* See Table 1 in the "Circuit design and circuit board design" section.

- ② When the surge absorber is placed between a live part and a metal case, it may cause electric shock if the surge absorber short-circuits. To avoid this, ground the metal case or shield it to prevent direct contact with the metal case.

##### ■ In case the surge absorber should short-circuit and generate smoke or ignite, immediately cut off current flow to the surge absorber.

##### ■ Rated voltage for UL certification, etc.

To allow the surge absorber to meet leak current requirements, etc., a maximum allowable circuit voltage and rated voltage are specified for the surge absorber.

When applying for UL certification, etc. of a device equipped with a surge absorber, ensure the working voltage of the device does not exceed the rated voltage of the surge absorber.

##### ■ An unexpected sharp rise in the working voltage, an incoming excessive surge, etc., may cause the surge absorber to generate smoke or ignite.

In such a case, fire spreading through the device should be prevented to avoid expanded damage. To achieve this, take a multi-protection measure, such as adopting fire-resistant materials that make up the outer shell components and structural materials.

#### Use environments and cleaning conditions

##### ■ Do not use the surge absorber in an outdoor environment where the surge absorber is exposed to sunlight.

##### ■ Do not use the surge absorber in which direct sunlight hits the surge absorber or near a heating element where the temperature of the surge absorber would rise above its working temperature.

##### ■ Do not use the surge absorber in a place where the surge absorber is exposed to wind or rain or a highly humid place where steam is emitted or dew concentrates.

- Do not use the surge absorber in a place filled with dust or salt, in an atmosphere contaminated with a corrosive gas, etc., or in liquids such as water, oil, chemical, or organic solvents.
- Do not wash the surge absorber with a solvent (thinner, acetone, etc.) that damages the outer sheath resin.

**Response to anomalies and handling conditions**

Be careful not to drop the surge absorber on the floor, etc. The product is likely to suffer mechanical or electrical damage when dropped on the floor. Avoid using such a product.

**Circuit design and circuit board design**

Meet the following requirements. Not following the requirements can result in a shorter lifespan of the surge absorber or its failure.

- Choose a surge absorber whose maximum allowable circuit voltage has a margin relative to the maximum voltage range including source voltage fluctuations.
  - \* See Table 1 in the "Circuit design and circuit board design" section.
- When surges are applied intermittently to the surge absorber at short intervals (when pulses of voltages are applied in a noise simulator test, etc.), make sure that the surge power does not exceed the maximum average pulse power of the surge absorber.
- The product numbers of recommended surge absorbers to choose are shown in Table 1.

(1) The case of placing the surge absorber between lines

When the source voltage is expected to rise temporarily due to unbalanced single-wire loads in a three-phase three-wire connection configuration, a short circuit between a voltage line and a neutral line, loss of the neutral line, or resonance of a capacitive load caused by switching on/off, use a surge absorber (varistor) indicated by "\*" in Table 1.

(2) The case of placing the surge absorber between a line and the ground

Line-to-ground voltage may rise with a single-wire ground fault, etc. Use a recommended surge absorber in Table 1 that is different from the surge absorber placed between lines. When the device is subjected to an insulation resistance test (500 V DC), use a D-type surge absorber indicated by "\*" in Table 1.

According to "Electrical Appliance Technical Standards" based on the Electrical Appliance and Material Safety Act, when using a varistor voltage which would fail the insulation performance test, the surge absorber may be removed from the device when being subjected to the test, depending on circuit test conditions.

\* See attached table 4, appendix 4, "Electrical Appliance Technical Standards" based on the Electrical Appliance and Material Safety Act.

■ Current fuse

(1) Select a surge absorber and the rated current for a current fuse to be used in a manner shown in the following table.

Confirm that no secondary accident arises when the surge absorber in an actual circuit breaks. Selected rated currents of current fuses shown in the following table are exemplary one and may vary depending on circuit conditions used. Confirm the rated current by a test, etc., before using the current fuse.

<Rated currents of current fuses for the D-type / E/E-S1 series surge absorbers>

Standard product number	ERZE05A□□□□	ERZE07A□□□□	ERZE08A□□□□	ERZE10A□□□□	ERZE11A□□□□	ERZE14A□□□□
Rating Current	5 A max.	7 A max.	7 A max.	10 A max.	10 A max.	10 A max.

\* Use the rated voltage of the current fuse that corresponds to the circuit voltage of a circuit including the current fuse.

(2) Recommended parts where fuses are connected are shown in Table 1. When a load current to a protected device is so large as to exceed the rated current of the fuse, however, connect the fuse in a location shown in the following diagram.

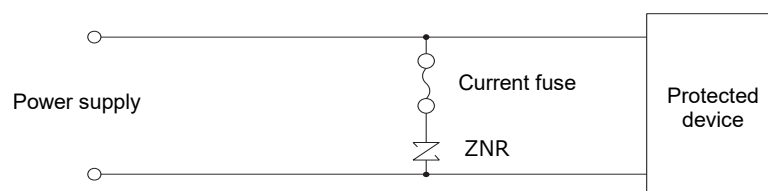

■ Temperature fuse

When connecting the surge absorber to a temperature fuse, choose a connection method and a temperature fuse that allow fine thermal coupling between the surge absorber and the temperature fuse.

Table 1 Application example of the product (ordinary application example)

	Surge absorber placed between lines	Surge absorber placed between a line and the ground																																	
Connection	<p>DC Single-phase AC</p>	<p>DC Single-phase AC</p>																																	
	<p>Three-phase AC</p>	<p>Three-phase AC</p>																																	
Varistor voltage selection	<table border="1"> <thead> <tr> <th>ZNR</th> <th>Power supply voltage [AC]</th> <th>Nominal varistor voltage</th> </tr> </thead> <tbody> <tr> <td rowspan="6">ZNR 1 ZNR 3</td> <td>100 V</td> <td>201 to 361*</td> </tr> <tr> <td>120 V</td> <td>241 to 431*</td> </tr> <tr> <td>200 V</td> <td>471 to 621*</td> </tr> <tr> <td>220 V</td> <td>471 to 621*</td> </tr> <tr> <td>240 V</td> <td>511, 621*</td> </tr> <tr> <td>380 V</td> <td>751, 821*</td> </tr> </tbody> </table>	ZNR	Power supply voltage [AC]	Nominal varistor voltage	ZNR 1 ZNR 3	100 V	201 to 361*	120 V	241 to 431*	200 V	471 to 621*	220 V	471 to 621*	240 V	511, 621*	380 V	751, 821*	<table border="1"> <thead> <tr> <th>ZNR</th> <th>Power supply voltage [AC]</th> <th>Nominal varistor voltage</th> </tr> </thead> <tbody> <tr> <td rowspan="6">ZNR 2 ZNR 4</td> <td rowspan="3">100 V 220 V</td> <td>471</td> </tr> <tr> <td>511</td> </tr> <tr> <td>621</td> </tr> <tr> <td rowspan="3">230 V 240 V</td> <td>821 or higher**</td> </tr> <tr> <td>511</td> </tr> <tr> <td>621*</td> </tr> <tr> <td>380 V</td> <td>821 or higher**</td> </tr> <tr> <td></td> <td></td> <td>112**</td> </tr> </tbody> </table>	ZNR	Power supply voltage [AC]	Nominal varistor voltage	ZNR 2 ZNR 4	100 V 220 V	471	511	621	230 V 240 V	821 or higher**	511	621*	380 V	821 or higher**			112**
	ZNR	Power supply voltage [AC]	Nominal varistor voltage																																
ZNR 1 ZNR 3	100 V	201 to 361*																																	
	120 V	241 to 431*																																	
	200 V	471 to 621*																																	
	220 V	471 to 621*																																	
	240 V	511, 621*																																	
	380 V	751, 821*																																	
ZNR	Power supply voltage [AC]	Nominal varistor voltage																																	
ZNR 2 ZNR 4	100 V 220 V	471																																	
		511																																	
		621																																	
	230 V 240 V	821 or higher**																																	
		511																																	
		621*																																	
380 V	821 or higher**																																		
		112**																																	
		<p>* Choose the element size while taking surge conditions into consideration.</p>																																	

**Processing conditions**

- Do not apply vibration, impact (drop impact, etc.), or pressure strong enough to crack the outer sheath resin or absorber body of the surge absorber.
- When coating the surge absorber with a resin or embedding it in a resin mold, avoid using a resin that degrades the surge absorber.
- Do not bend or apply a force to the lead of a D-type surge absorber close to the outer sheath resin.

**Mounting and storage conditions**

- When soldering the surge absorber, follow recommended soldering conditions shown in the following table so that solder or the insulation material making up the surge absorber is not melted.
- When making holes for mounting the surge absorber on the board, check the dimensions of the holes on the board, referencing the central point of the interval between the leads.  
Because the overall dimensional tolerance is large, forming the holes with high precision requires careful processing.

	Soldering method	Recommended conditions	Mater to note
D-type	Flow soldering (solder bath immersion method)	260 °C, 10 seconds or less	A D-type surge absorber should not be soldered by reflow soldering.

Note 1: Soldering the surge absorber under soldering conditions different from the recommended soldering conditions requires extra checking to ensure it won't cause any problems.  
Additional soldering is allowed only once. It must be done within 5 seconds, with the soldering iron temperature kept at 400 °C or lower.

Note 2: A temperature profile may include a large error, depending on the measurement method used.  
Be careful in such cases.

Note 3: Board temperatures vary depending on the sizes of boards and mounting densities. Confirm the temperature for each type of board.

<Recommended soldering temperature profile>

Flow soldering (solder bath immersion method)

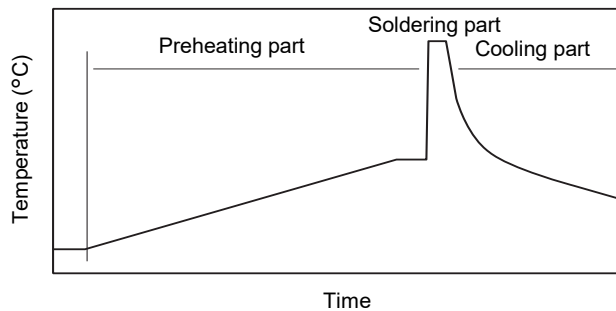

Preheating part	Normal temperature to 130 °C	120 seconds or less
Soldering part	260 °C or less	10 seconds or less
Cooling part	Gradual cooling (cooling under the normal temperature)	

- Do not keep the product in a high-temperature or high-humidity condition. Keep the surge absorber in a room with a temperature of 40 °C or lower and a relative humidity of 75% or lower and use the surge absorber within two years of storage. Check the solderability of a surge absorber stored for a long period (two years or more) before using the surge absorber.
- Keep the surge absorber in a place where no corrosive gas atmosphere (hydrogen sulfide, sulfurous acid, chlorine, ammonia, etc.) is present.
- Keep the surge absorber in a place where the surge absorber is protected from direct sunlight, dew concentration, etc.