

Power supply CP-E 12/2.5

Primary switch mode power supply







The CP-E range offers enhanced functionality while the number of different types has been considerably reduced. Now all power supply units can be operated at an ambient temperature of up to +70 °C.



Characteristics

- Rated output voltage 12 V DC
- Output voltage adjustable via front-face rotary potentiometer “OUTPUT Adjust”
- Rated output current 2.5 A
- Rated output power 30 W
- Wide range input 100-240 V AC (85-264 V AC, 90-375 V DC)
- Typical efficiency of 84 %
- Low power dissipation and low heating
- Free convection cooling (no forced cooling with ventilators)
- Ambient temperature range during operation -40...+70 °C
- Open-circuit, overload and short-circuit stable
- Integrated input fuse
- Redundancy unit CP-RUD offering true redundancy, available as accessory
- LED for status indication

Approvals

-  UL 508, CAN/CSA C22.2 No.107.1 ¹⁾
-  UL 1310, CAN/CSA C22.2 No.223 (Class 2 Power Supply)
-  ANSI/ISA-12.12, CAN/CSA C22.2 No. 213 (Class I, Div. 2, hazardous locations)
-  UL 60950, CAN/CSA C22.2 No.60950 ¹⁾
-  EAC
-  CCC ¹⁾

¹⁾ Approval refers to rated input voltage U_{in}

Marks

-  CE
-  RCM

Order data

Type	Input voltage range	Rated output voltage / current	Order code
CP-E 12/2.5	85-264 V AC / 90-375 V DC	12 V DC / 2.5 A	1SVR 427 032 R1000

Order data – accessories

Type	Description	Order code
CP-RUD	Redundancy unit The CP-RUD provides decoupling of two CP-E power supply units ≤ 35 V and < 5 A.	1SVR 423 418 R9000

Functions



- 1** OUTPUT L+, L-:
terminals – output
- 2** INPUT L, N, PE:
terminals – input
- 3** OUTPUT OK:
green LED – output voltage OK
- 4** OUTPUT Adjust:
potentiometer – adjustment of the output voltage
- 5** Circuit diagram

Application

The primary switch mode power supply offers two voltage input ranges. This enables the supply with AC or DC. Furthermore it is equipped with two generous capacitors, which ensure mains buffering of at least 30 ms (at 230 V AC). That is why the devices can be used worldwide also in high fluctuating networks and battery-powered plants.

Operating mode

By means of the potentiometer “OUTPUT Adjust” the output voltage can be adjusted within a range of 12 to 14 V DC. Thus, the power supply can be optimally adapted to the application, e.g. compensating the voltage drop caused by a long line length.

The green LED “OK” is lightening during proper operation.

Installation

Mounting

The switch mode power supply can be snapped on a DIN rail according to IEC/EN 60715 as shown in the accompanying picture. For that the device is set with its mounting rail slide on the upper edge of the mounting rail and locked by lifting it downwards.

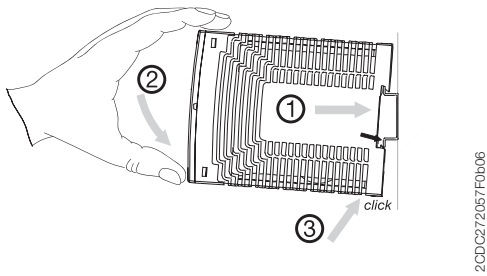

Demounting

Remove the switch mode power supply as shown in the accompanying picture. For that the latching lever is pulled downwards by means of the screwdriver. Alternatively you can press the unlock button to release the device. Then in both cases the device can be unhinged from the mounting rail edge and removed.

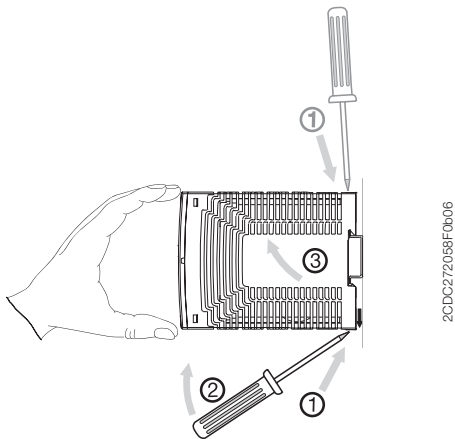

Mounting position

The devices have to be mounted horizontally with the input terminals on the bottom. In order to ensure a sufficient convection, the minimum distance to other modules should not be less than 25 mm in vertical and horizontal direction.

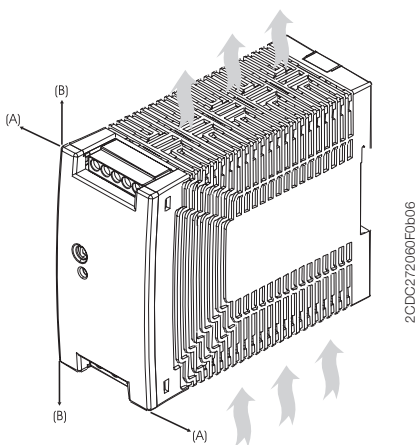

Electrical connection

Connect the input terminals L and N. The protective earth conductor PE must be connected. The installation must be executed acc. to EN 60950, provide a suitable disconnecting device (e. g. line protection switch) in the supply line. The input side is protected by an internal input fuse.

Rate the lines for the maximum output current (considering the short-circuit current) or provide a separate fuse protection. We recommend to choose the cable section as large as possible in order to minimize voltage drops. Observe the polarity. The device is overload, short-circuit and open-circuit proof. The secondary side of the power supply unit is electrically isolated from the input and internally not earthed (SELV) and can therefore be earthed by the user according to the needs with L+ or L- (PELV).

Connection diagram

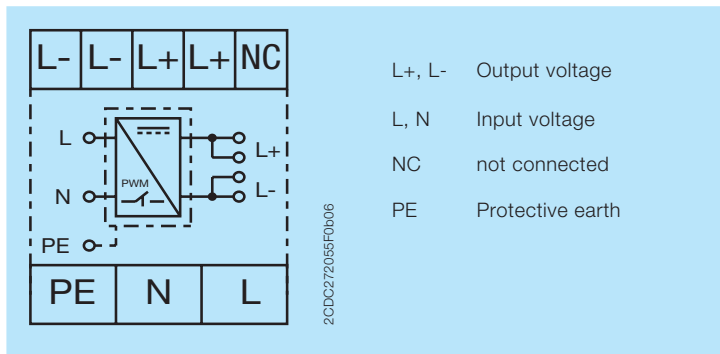

Safety instructions and warnings

The device must be installed by qualified persons only and in accordance with the specific national regulations (e.g., VDE, etc.). The devices are maintenance-free chassis-mounted units.



Disconnect system from supply network!

Before any installation, maintenance or modification work: Disconnect the system from the supply network and protect against switching on.

Before start of operation:

Attention! Improper installation/operation may impair safety and cause operational difficulties or destruction of the unit. Before operation the following must be ensured:

- Connect to main according to the specific national regulations.
- Power supply cables and unit must be sufficiently fused. A disconnecting device has to be provided for the power supply to disengage unit and supply cables from supply mains if required.
- The protective earth conductor must be connected to the terminal PE (Protection class I)
- The secondary side of the power supply unit is not earthed and can be earthed by the user according to the needs with L+ or L-.
- Rate the output lines for the output current of the power supply and connect them with the correct polarity.
- In order to ensure sufficient air-cooling the distance to other devices has to be considered.

In operation:

- Do not modify the installation (primary and secondary side)! High current! Risk of electric arcs and electric shocks (danger to life)!
- Risk of burns: Depending on the operation conditions the enclosure can become very hot.
- The internal fuse is not user-replaceable. If the internal fuse blows, most probably the device is defective. In this case, an examination of the switch mode power supply by the manufacturer is necessary.



Attention! High voltage! Danger to life!

The power supplies contain components with high stored energy and circuits with high voltage! Do not introduce any objects into the unit, and do not open the unit. With some units of this range the output is capable of providing hazardous energy. Ensure that the service personnel is protected against inadvertent contact with parts carrying energy.

Technical data

Data at $T_a = 25\text{ °C}$, $U_{in} = 230\text{ V AC}$ and rated values, unless otherwise indicated

Input circuits

Supply circuits		
Rated input voltage U_{in}	L,N	100-240 V AC
Input voltage range	AC	85-264 V
	DC	90-375 V
Frequency range	AC	47-63 Hz
Typical input current	at 115 V AC	560 mA
	at 230 V AC	330 mA
Typical power consumption		35.9 W
Inrush current limiting	at 115 V AC	20 A (max. 3 ms)
	at 230 V AC	40 A (max. 3 ms)
Discharge current	input / output	0.25 mA
	input / PE	3.5 mA
Power failure buffering time	at 115 V AC	min. 20 ms
	at 230 V AC	min. 30 ms
Internal input fuse		2 A slow-acting / 250 V AC
Power factor correction (PFC)		no

User interface

Indication of operational states		
Output voltage	OUTPUT OK: green LED	 : output voltage OK

Output circuit

Rated output voltage	L+, L+, L-, L-	12 V DC
Tolerance of the output voltage		0 ... +1 %
Adjustment range of the output voltage		12-14 V DC
Rated output power		30 W
Rated output current I_r	$T_a \leq 60\text{ °C}$	2.5 A
Derating of the output current	$60\text{ °C} < T_a \leq 70\text{ °C}$	2.5 %/°C
Maximum deviation with	load change statical	$\pm 0.5\%$
	change of output voltage within the input voltage range	$\pm 0.5\%$
Control time		< 2 ms
Starting time after applying the supply voltage	at I_r	max. 1 s
	with 3500 μF	max. 2 s
Rise time	at I_r	max. 150 ms
	with 3500 μF	max. 500 ms
Fall time		max. 150 ms
Residual ripple and switching peaks	BW = 20 MHz	50 mV
Parallel connection		yes, to enable redundancy
Series connection		yes, to increase voltage
Resistance to reverse feed		1 s – max. 18 V DC

Output circuit – no-load, overload and short-circuit behaviour

Characteristic curve of output	U/I characteristic curve
Short-circuit protection	continuous short-circuit proof
Short-circuit behaviour	continuation with output power limiting
Overload protection	output power limiting
No-load protection	continuous no-load stability
Starting of capacitive loads	3500 μF

General data

Power dissipation		typ. 5.6 W
Efficiency		typ. 84 %
Duty time		100 %
Dimensions (W x H x D)		40.5 x 90 x 114 mm (1.59 x 3.54 x 4.49 in)
Weight		0.287 kg (0.633 lb)
Material of housing		Plastic
Mounting		DIN rail (IEC/EN 60715), snap-on mounting without any tool
Mounting position		horizontal
Minimum distance to other units	horizontal / vertical	25 mm / 25 mm (0.98 in / 0.98 in)
Degree of protection	housing / terminals	IP20 / IP20
Protection class		I

Electrical connection – input circuit / output circuit

Connecting capacity	fine-strand with wire end ferrule	0.2-2.5 mm ² (24-14 AWG)
	fine-strand without wire end ferrule	
	rigid	
Stripping length		6 mm (0.24 in)
Tightening torque		0.6 Nm (5 lb.in)

Environmental data

Ambient temperature range	operation	-40...+70 °C (-40...+158 °F)
	rated load	-40...+60 °C (-40...+140 °F)
	storage	-40...+85 °C (-40...+185 °F)
Damp heat		95 % RH, without condensation
Vibration (sinusoidal) (IEC/EN 60068-2-6)		10-500 Hz, 2 G, along X, Y, Z each axis, 60 min. for each axis
Shock (half-sine) (IEC/EN 60068-2-27)		15 G, 11 ms, 3 axis, 6 faces, 3 times for each face

Isolation data

Rated insulation voltage U _i	input / output	3 kV AC
	input / PE	1.5 kV AC
	output / PE	0.5 kV AC; 0.71 kV DC
Pollution degree		2
Overvoltage category		II

Standards / Directives

Standards	IEC/EN 60950-1
Low Voltage Directive	2014/35/EU
Protective low voltage	SELV (IEC/EN 60950-1)
EMC Directive	2014/30/EU
RoHS Directive	2011/65/EU

Electromagnetic compatibility

Interference immunity to		IEC/EN 61000-6-2
electrostatic discharge	IEC/EN 61000-4-2	Level 4 (air discharge 15 kV / contact discharge 8 kV)
radiated, radio-frequency, electromagnetic field	IEC/EN 61000-4-3	Level 3 (10 V/m)
electrical fast transient / burst	IEC/EN 61000-4-4	Level 4 (4 kV / 5 kHz)
surge	IEC/EN 61000-4-5	L-L Level 3 (2 kV) / L-PE Level 4 (4 kV)
conducted disturbances, induced by radio-frequency fields	IEC/EN 61000-4-6	Level 3 (10 V)
power frequency magnetic fields	IEC/EN 61000-4-8	Level 4 (30 A/m)
voltage dips, short interruptions and voltage variations	IEC/EN 61000-4-11	dip: >95 % 10 ms / >30 % 500 ms interruptions: >95 % 5000 ms
Interference emission		IEC/EN 61000-6-3
high-frequency radiated	IEC/CISPR 22, EN 55022	Class B
high-frequency conducted	IEC/CISPR 22, EN 55022	Class B
limits for harmonic current emissions	IEC/EN 61000-3-2	Class A

Technical diagrams

Output behaviour

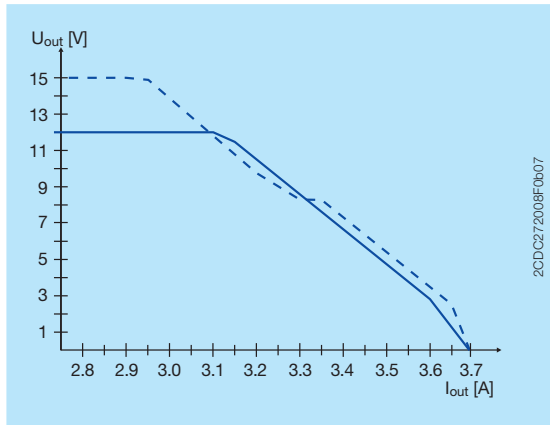

Characteristic curve of output at $T_a = 25$ °C

The switch mode power supply CP-E 12/2.5 is able to supply at 12 V DC output voltage and

- at an ambient temperature of:
≤ 60 °C a continuous output current of approx. 2.5 A
- at ambient temperatures of:
60 °C < T_a ≤ 70 °C the output power has to be reduced by 2.5 % per °C temperature increase.

If the switch mode power supply is loaded with an output current > 2.5 A, the operating point is passing through the U/I characteristic curve shown.

Temperature behaviour

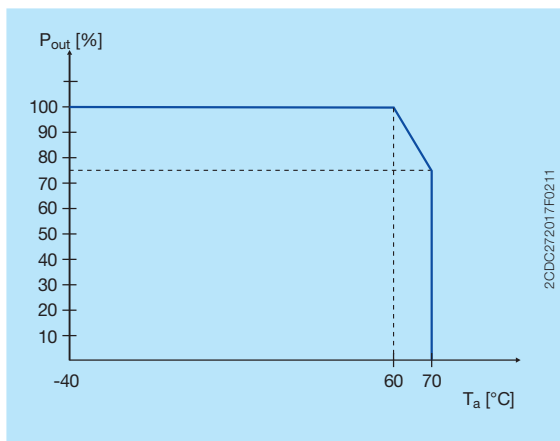

Characteristic curve of temperature at rated load

Dimensions

in mm [inches]

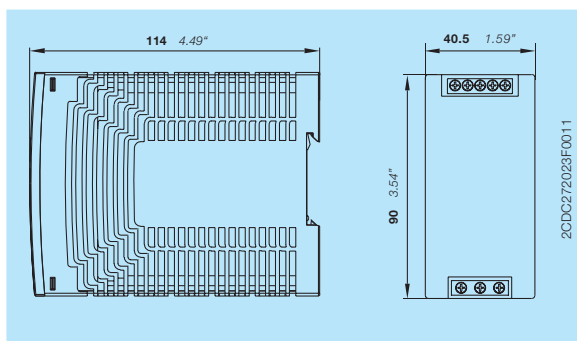

CP-E 12/2.5

Dimensions accessories

in mm [inches]

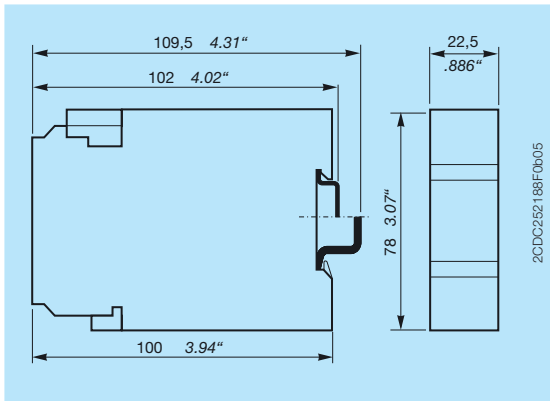

CP-RUD

Further documentation

Document title	Document type	Document number
Electronic Products and Relays	Technical catalogue	2CDC 110 004 C02xx
Power Supply Units	Application manual	2CDC 114 048 M020x
Redundancy unit CP-RUD	Data sheet	2CDC 114 032 D0201

You can find the documentation on the internet at www.abb.com/lowvoltage
-> Automation, control and protection -> Power supplies.

CAD system files

You can find the CAD files for CAD systems at <http://abb-control-products.partcommunity.com>
-> Low Voltage Products & Systems -> Control Products -> Power Supplies.

Contact us

ABB STOTZ-KONTAKT GmbH

P. O. Box 10 16 80

69006 Heidelberg, Germany

Phone: +49 (0) 6221 7 01-0

Fax: +49 (0) 6221 7 01-13 25

E-mail: info.desto@de.abb.com

You can find the address of your
local sales organisation on the
ABB home page

<http://www.abb.com/contacts>

-> Low Voltage Products and Systems

Note:

We reserve the right to make technical changes or modify the contents of this document without prior notice. With regard to purchase orders, the agreed particulars shall prevail. ABB AG does not accept any responsibility whatsoever for potential errors or possible lack of information in this document.

We reserve all rights in this document and in the subject matter and illustrations contained therein. Any reproduction, disclosure to third parties or utilization of its contents – in whole or in parts – is forbidden without prior written consent of ABB AG.

Copyright © 2016 ABB
All rights reserved