

Temperature Controller

E5CB (48 × 48 mm)

Ideal for heater control, these Temperature Controllers offer the highest control performance at surprisingly low cost!

Easy to Read with One of the Largest Character Displays Anywhere.

- Improved visibility with character height of approx. 16 mm.
- Depth beyond front panel: Only 60 mm.
- Fewer parameters for simple setup.
- Faster sampling at 250 ms.
- High reliability with a three-year warranty.



48 × 48 mm

NEW

Refer to *Safety Precautions* on page 8.

Main I/O Functions

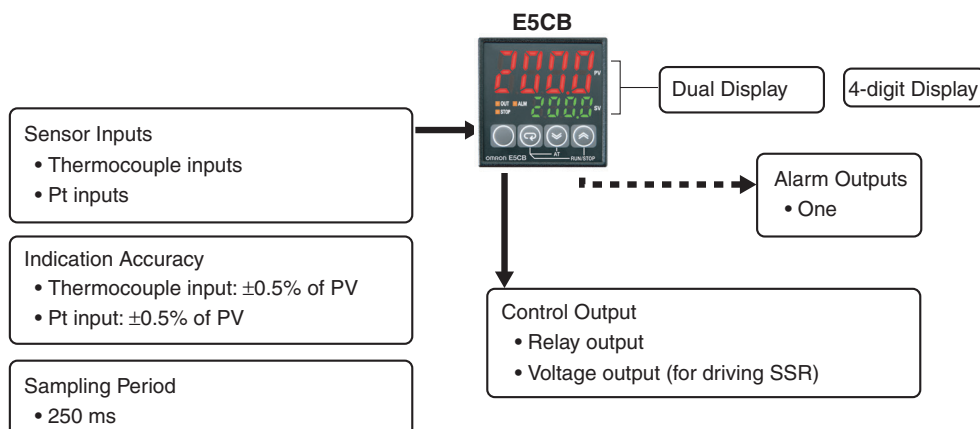

Model Number Structure

Model Number Legend

E5CB- 1

1 2 3 4

- Control Output**
 - R: Relay output: 250 VAC, 3 A
 - Q: Voltage output (for driving SSR): 12 VDC, 21 mA
- Alarm**
 - 1: Relay output: 250 VAC, 1 A (resistive load)
- Sensor type**
 - TC: Thermocouple (K, J, T, R, or S)
 - P: Platinum resistance thermometer (Pt100)
- Power Supply Voltage**
 - Blank: 100 to 240 VAC
 - D: 24 VAC/VDC

E5CB

Ordering Information

Temperature Controllers

Size	Power supply voltage	Input type	Alarm output	Control output	Model
E5CB 48 × 48 mm	100 to 240 VAC	Thermocouple	1	Relay output	E5CB-R1TC
		Platinum resistance thermometer			E5CB-R1P
		Thermocouple		Voltage output (for driving SSR)	E5CB-Q1TC
		Platinum resistance thermometer			E5CB-Q1P
	24 VAC/VDC	Thermocouple		Relay output	E5CB-R1TCD
		Platinum resistance thermometer			E5CB-R1PD
		Thermocouple		Voltage output (for driving SSR)	E5CB-Q1TCD
		Platinum resistance thermometer			E5CB-Q1PD

Accessories (Order Separately)

Terminal Cover

Model	E53-COV19
-------	-----------

Front Cover

Type	Model
Hard Front Cover	Y92A-48B
Soft Front Cover	Y92A-48D

USB-Serial Conversion Cable

Model	E58-CIFQ2
-------	-----------

Mounting Adapter (Included)

Model	Y92F-49
-------	---------

Adapter

Model	Y92F-45
-------	---------

- Note:** 1. Use this Adapter when the Front Panel has already been prepared for the E5B□.
2. Only black is available.

Waterproof Packing (Included)

Model	Y92S-P6
-------	---------

Unit Seal

Model	Y92S-L2
-------	---------

Specifications

Ratings

Power supply voltage	100 to 240 VAC 50/60 Hz, 24 VAC 50/60 Hz, or 24 VDC	
Operating voltage range	85% to 110% of rated supply voltage	
Power consumption	Approx. 3.5 VA (100 to 240 VAC) Approx. 3.5 VA (24 VAC) Approx. 2.5 W (24 VDC)	
Sensor input	Models with thermocouple inputs Thermocouple: K, J, T, R, or S (JIS C 1602-1995, IEC60584-1) Models with platinum resistance thermometer inputs Platinum resistance thermometer: Pt100 (JIS C 1604-1997, IEC60751)	
Control output	Relay output	SPST-NO, 250 VAC, 3 A (resistive load), electrical life: 100,000 operations, minimum applicable load: 5 V, 10 mA
	Voltage output (for driving SSR)	Output voltage: 12 VDC +25%/–15% (PNP), max. load current: 21 mA, with short-circuit protection circuit
Alarm output	Relay output	SPST-NO, 250 VAC, 1 A (resistive load), electrical life: 100,000 operations, minimum load: 5 V, 10 mA
Control method	ON/OFF control or 2-PID control (with auto-tuning)	
Setting method	Digital setting using front panel keys	
Indication method	7-segment digital display and individual indicators Character height: 16.2 mm (PV)	
Other functions	Temperature input shift, run/stop, protection functions, etc.	
Ambient operating temperature	–10 to 55°C (with no condensation or icing)/With a three-year guarantee: –10 to 50°C	
Ambient operating humidity	25% to 85%	
Storage temperature	–25 to 65°C (with no condensation or icing)	

Input Ranges

Models with Thermocouple Inputs

Model (temperature input)	Set value	Input type	Range	
			°C	°F
TC input	0	K	-200 to 1,300	-300 to 2,300
	1		-20.0 to 500.0	0.0 to 900.0
	2	J	-100 to 850	-100 to 1500
	3		-20.0 to 400.0	0.0 to 750.0
	4	T	-200 to 400	-300 to 700
	5		-199.9 to 400.0	-199.9 to 700.0
	6	R	0 to 1,700	0 to 3,000
7	S	0 to 1,700	0 to 3,000	

Default setting: 0

Applicable standards (K, J, T, R, S): JIS C1602-1995 and IEC 60584-1

Platinum Resistance Thermometer Input

Model (temperature input)	Set value	Input type	Range	
			°C	°F
Pt input	8	Pt100	-200 to 850	-300 to 1500
	9		-199.9 to 500.0	-199.9 to 900.0

Default setting: 8

Applicable standards (Pt100): JIS C1604-1997 and IEC 60751

Alarm Types

Select alarm types out of the 11 alarm types listed in the following table.

Setting	Alarm type	Positive alarm value (X)	Negative alarm value (X)	Deviation alarm/absolute value alarm
0	No alarm	Output OFF		
1	Upper/lower limit		Always ON	Deviation alarm
2	Upper limit			Deviation alarm
3	Lower limit			Deviation alarm
4	Upper/lower range		Always OFF	Deviation alarm
5 (See note 2.)	Upper/lower limit standby sequence ON		Always OFF	Deviation alarm
6 (See note 2.)	Upper limit standby sequence ON			Deviation alarm
7 (See note 2.)	Lower limit standby sequence ON			Deviation alarm
8	Absolute value upper limit			Absolute value alarm
9	Absolute value lower limit			Absolute value alarm
10 (See note 2.)	Absolute value upper limit standby sequence ON			Absolute value alarm
11 (See note 2.)	Absolute value lower limit standby sequence ON			Absolute value alarm
12	Do not set.			

Note: 1. The default is 2.

2. Alarms with a Standby Sequence

The alarm is blocked until the first safe-state is reached.

Unwanted alarm during start-up are prevented.

Example: Deviation Lower Limit Standby Sequence ON

The standby sequence is cleared when the alarm OFF condition has been met.

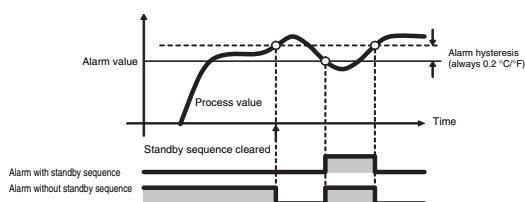

The standby sequence is started again when any of the following conditions is met.

- Operation is started (power is turned ON or operation is switched from stop to run).
- The alarm value is changed.
- The temperature input offset is changed.
- The set point is changed.

Characteristics

Indication accuracy	Thermocouple: (See note 1.) (±0.5% of indicated value or ±1°C, whichever is greater) ±1 digit max. Platinum resistance thermometer: (±0.5% of indicated value or ±1°C, whichever is greater) ±1 digit max.	
Influence of temperature (See note 2.)	R and S thermocouple inputs: (±1% of PV or ±10°C, whichever is greater) ±1 digit max. K, J, and T thermocouple inputs: (±1% of PV or ±4°C, whichever is greater) ±1 digit max. Platinum resistance thermometer inputs: (±1% of PV or ±2°C, whichever is greater) ±1 digit max.	
Influence of voltage (See note 2.)		
Hysteresis	0.1 to 999.9 (in units of 0.1) °C/°F	
Proportional band (P)	0.1 to 999.9 (in units of 0.1) °C/°F	
Integral time (I)	0 to 3999 s (in units of 1 s)	
Derivative time (D)	0 to 3999 s (in units of 1 s)	
Control period	0.5, 1 to 99 s (in units of 1 s)	
Alarm setting range	-1999 to 9999 (decimal point position depends on input type)	
Input sampling period	250 ms	
Affect of signal source resistance	Thermocouple: 0.1°C/Ω max. (100 Ω max.) (See note 3.) Platinum resistance thermometer: 0.6°C/Ω max. (10 Ω max.)	
Insulation resistance	20 MΩ min. (at 500 VDC)	
Dielectric strength	2,300 VAC, 50 or 60 Hz for 1 min (between terminals with different charge)	
Vibration resistance	Malfunction	10 to 55 Hz, 20 m/s ² for 10 min each in X, Y, and Z directions
	Destruction	10 to 55 Hz, 20 m/s ² for 2 hrs each in X, Y, and Z directions
Shock resistance	Malfunction	200 m/s ² , 3 times each in X, Y, and Z directions
	Destruction	300 m/s ² , 3 times each in X, Y, and Z directions
Weight	Controller: Approx. 100 g, Mounting Bracket: Approx. 10 g	
Degree of protection	Front panel: IP66 Rear case: IP20, Terminals: IP00	
Memory protection	Non-volatile memory (number of writes: 100,000 times)	
Conformed standards	Certified standards	UL 61010-1, CSA C22.2 No. 1010-1
	Applicable standards	EN61326, EN61010-1, IEC61010-1 VDE0106, Part 100 (Finger protection), when the terminal cover is mounted.
EMC	EMI	EN61326
	Emission Enclosure:	EN55011 Group1 Class A
	Emission AC Mains:	EN55011 Group1 Class A
	EMS	EN61326
	Immunity ESD:	EN61000-4-2
	Immunity RF-interference:	EN61000-4-3
	Immunity Burst:	EN61000-4-4
	Conduction Disturbance Immunity	EN61000-4-6
	Immunity Surge:	EN61000-4-5
	Immunity Voltage Dip/Interrupting:	EN61000-4-11

- Note:** 1. The indication accuracy of K and T thermocouples at a temperature of -100°C max. is ±2°C ±1 digit maximum. The indication accuracy of the R and S thermocouples at a temperature of 200°C max. is ±3°C ±1 digit max.
2. Conditions: Ambient temperature: -10 to 23 to 55°C, Voltage range: -15% to ±10% of rated voltage
3. R, and S sensors: 0.2°C/Ω max. (100 Ω max.)

Electrical Life Expectancy Curve for Relays (Reference Values)

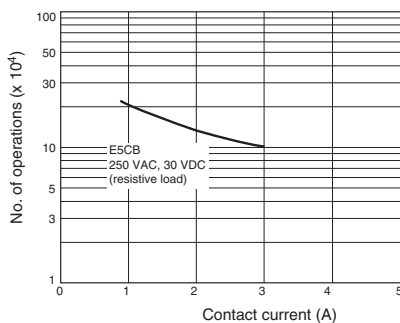

USB-Serial Conversion Cable Specifications

Applicable OS	Windows 2000, XP, Vista, or 7
Applicable software	Thermo Mini
Applicable models	E5CB Series
USB interface standard	USB specification 1.1
DTE speed	38,400 bps
Connector Specifications	Computer: USB (Type A plug) Temperature Controller: Special serial connector
Power supply	Bus power (supplied from the USB host controller)
Power supply voltage	5 VDC
Current consumption	450 mA max.
Output voltage	4.7±0.2 VDC (Supplied from USB-Serial Conversion Cable to the Temperature Controller.)
Output current	250 mA max. (Supplied from USB-Serial Conversion Cable to the Temperature Controller.)
Ambient temperature	0 to 55°C (with no condensation or icing)
Ambient humidity	10% to 80%
Storage temperature	-20 to 60°C (with no condensation or icing)
Storage humidity	10% to 80%
Altitude	2,000 m max.
Weight	Approx. 120 g

- Note:** 1. A high-power port is used for the USB port.
2. A driver must be installed on the computer. Refer to the *Instruction Manual* included with the Cable for the installation procedure.

External Connections

- A voltage output (control output) is not electrically insulated from the internal circuits. When using a grounding thermocouple, do not connect any of the control output terminals to ground. If the control output terminals are connected to ground, errors will occur in the measured temperature values as a result of leakage current.

E5CB

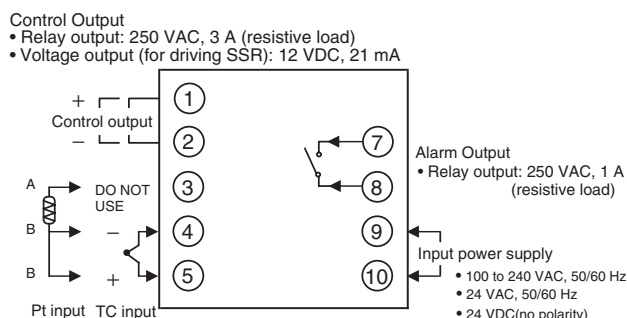

Nomenclature

E5CB

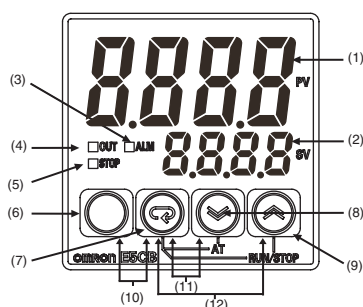

- | | | |
|-------------------|--|--|
| (1) Display No. 1 | Displays the process value (PV) or parameter. | (10) Press these keys for at least 3 seconds in Operation Level or Adjustment Level to go to Protect Level. Press these keys for at least 1 second in Protect Level to return to Operation Level. |
| (2) Display No. 2 | Displays the set point (SP) or parameter setting. | |
| (3) ALM | Lit while the alarm is ON. Not lit while the alarm is OFF. | |
| (4) OUT | Lit while the control output is ON. Not lit while the control output is OFF. | (11) Press these keys for at least 2 seconds to start or stop autotuning.*1 |
| (5) STOP | Not lit during operation. Lit while operation is stopped. | (12) Press these keys for at least 2 seconds to start or stop operation.*2 |
| (6) | Level Key: Changes the setting level. | *1: These keys are disabled when starting and stopping autotuning has been disabled with operation control key protection. |
| (7) | Mode Key: Changes the parameter within the setting level. | *2: These keys are disabled when starting and stopping operation has been disabled with operation control key protection. |
| (8) | Down Key: Reduces the setting. | |
| (9) | Up Key: Increases the setting. | |

Dimensions

(Unit: mm)

E5CB

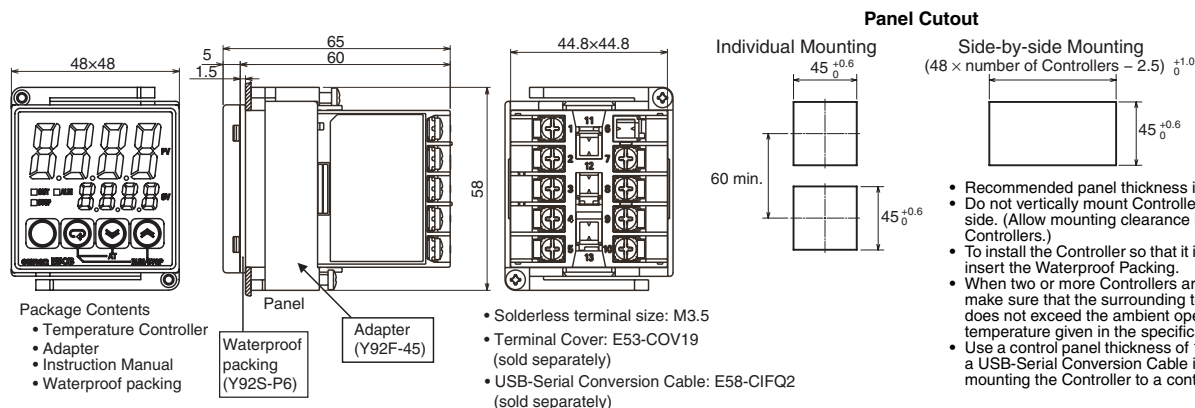

The Support Software port is on the top of the Temperature Controller. This port is used to connect the Temperature Controller to a personal computer. The E58-CIFQ2 USB-Serial Conversion Cable is required to make the connection. For details on connection methods, refer to the *E58-CIFQ2 USB-Serial Conversion Cable Instruction Manual*.
*Do not leave the USB-Serial Conversion Cable connected while using the Temperature Controller.

E5CB

Accessories (Order Separately)

Terminal Cover E53-COV19

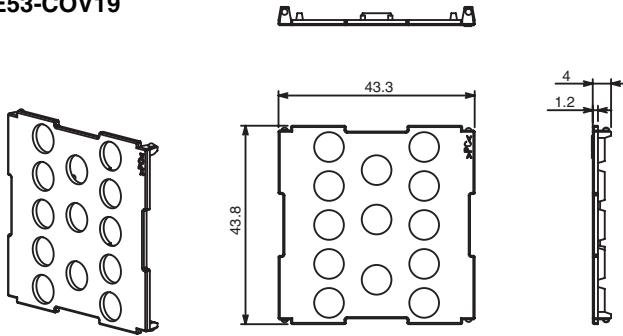

Note: The E53-COV10 cannot be used.

Waterproof Packing Y92S-P6

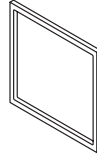

Order the Waterproof Packing separately if it becomes lost or damaged.
The Waterproof Packing can be used to achieve an IP66 degree of protection.
(Deterioration, shrinking, or hardening of the waterproof packing may occur depending on the operating environment. Therefore, periodic replacement is recommended to ensure the level of waterproofing specified in IP66. The time for periodic replacement depends on the operating environment. Be sure to confirm this point at your site. Consider one year a rough standard. OMRON shall not be liable for the level of water resistance if the customer does not perform periodic replacement.)
The Waterproof Packing does not need to be attached if a waterproof structure is not required.

USB-Serial Conversion Cable E58-CIFQ2

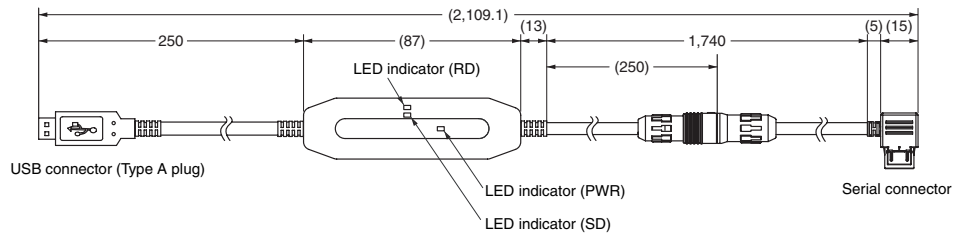

Adapter

Note: 1. Use this Adapter when the Front Panel has already been prepared for the E5B□.
2. Only black is available.

Y92F-45

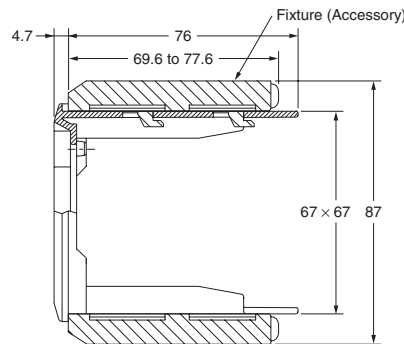
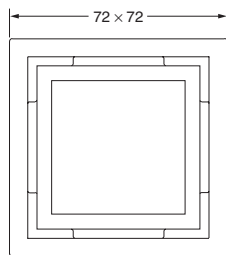
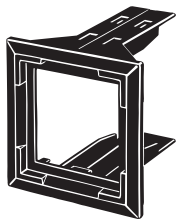

Mounted to E5CB

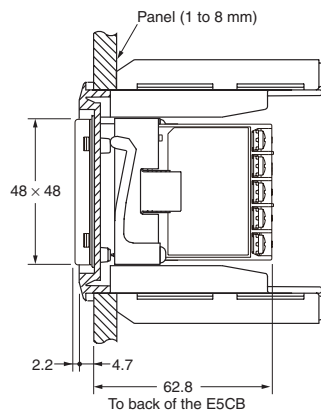
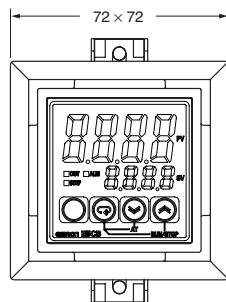
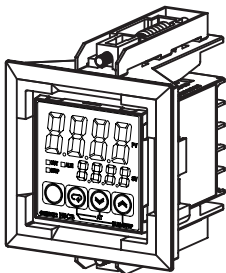

Operating Procedure

Parameters

Depending on the settings, some data may not be displayed.

For details, refer to the *Instruction Manual*.

Operation will stop when the level is switched from Operation Level to Initial Setting Level.

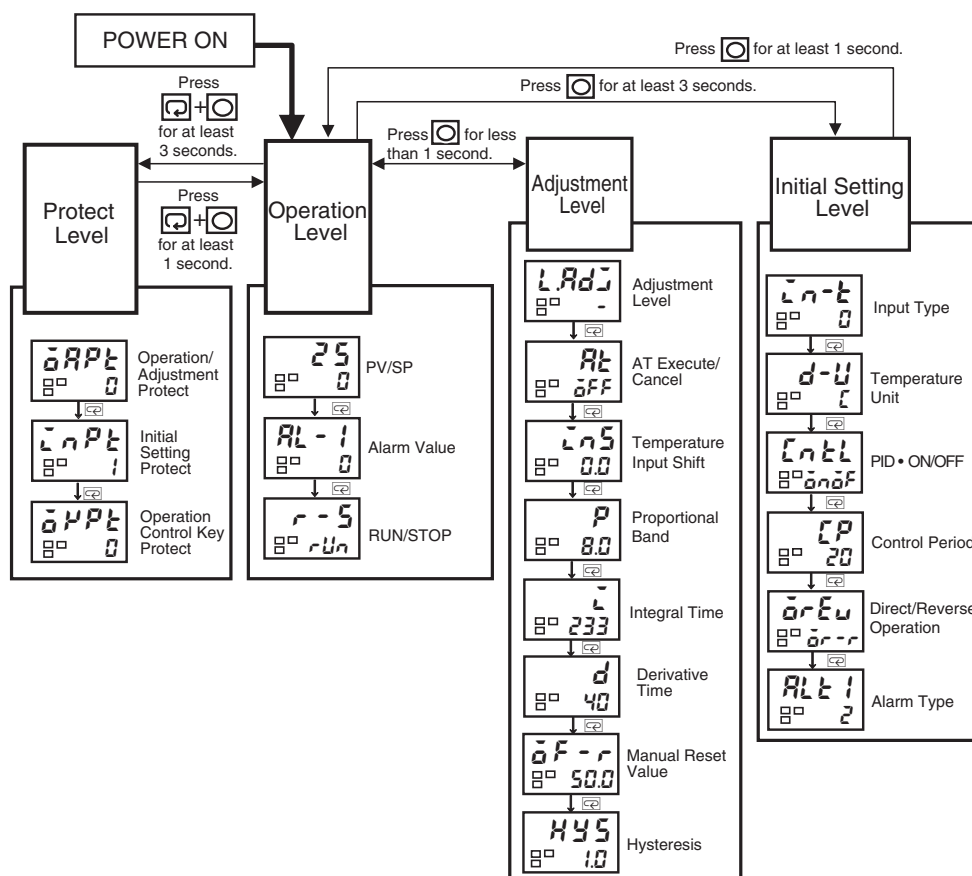

Troubleshooting

When an error has occurred, the display No.1 shows the error code.

Take necessary measure according to the error code, referring the following table.

Display	Meaning	Action
S.ERR (S.ERR)	Input error*1	Check the wiring of inputs, disconnections, short circuits and input type.
E111 (E111)	RAM memory error	Turn the power OFF then back ON again.*2
E111/SUM (E111)/(SUM)*3	Non-volatile memory error	Press the [Enter] and [Down] Keys for at least 3 seconds to initialize the settings and clear the non-volatile memory error.*2

• The control output and the alarm output will turn OFF when an error occurs. (For S.ERR, the alarm output will be processed for a high temperature error.)

• If the input value exceeds the display limit (–1999 to 9999) but it is still within the control range, cccc will be displayed for values under –1999. Under these conditions, the control output and alarm output will operate normally.

*1. This error is displayed only when the process value and set point are displayed.

*2. If the display does not change, the Controller needs to be repaired.

If operation returns to normal, then noise may have caused the problem. Check for noise.

*3. E111 will be displayed on display No. 1 and SUM will be displayed on display No. 2.

Safety Precautions

Refer to *Safety Precautions for All Temperature Controllers*.

CAUTION

Do not touch the terminals while power is being supplied.

Doing so may occasionally result in minor injury due to electric shock.



Do not allow pieces of metal, wire clippings, or fine metallic shavings or filings from installation to enter the product. Doing so may occasionally result in electric shock, fire, or malfunction.



Do not use the product where subject to flammable or explosive gas. Otherwise, minor injury from explosion may occasionally occur.



Do not use the Temperature Controller or the USB-Serial Conversion Cable if it is damaged. Doing so may occasionally result in minor electric shock or fire.



Never disassemble, modify, or repair the product or touch any of the internal parts. Minor electric shock, fire, or malfunction may occasionally occur.



CAUTION - Risk of Fire and Electric Shock

a) More than one disconnect switch may be required to de-energize the equipment before servicing the product.

b) Caution: To reduce the risk of fire or electric shock, do not interconnect the outputs of different Class 2 circuits. *



If the output relays are used past their life expectancy, contact fusing or burning may occasionally occur. Always consider the application conditions and use the output relays within their rated load and electrical life expectancy. The life expectancy of output relays varies considerably with the output load and switching conditions.



Tighten the terminal screws to the rated torque of between 0.74 and 0.90 N·m. Loose screws may occasionally result in fire.



Set the parameters of the product so that they are suitable for the system being controlled. If they are not suitable, unexpected operation may occasionally result in property damage or accidents.



A malfunction in the product may occasionally make control operations impossible or prevent alarm outputs, resulting in property damage. To maintain safety in the event of malfunction of the product, take appropriate safety measures, such as installing a monitoring device on a separate line.



Do not allow pieces of metal or wire cuttings to get inside the USB-Serial Conversion Cable connector for the Support Software. Failure to do so may occasionally result in minor electric shock, fire, or damage to equipment.



Do not allow dust and dirt to collect between the pins in the connector on the USB-Serial Conversion Cable. Failure to do so may occasionally result in fire.



* A class 2 power supply is one tested and certified by UL as having the current and voltage of the secondary output restricted to specific levels.

Precautions for Safe Use

Be sure to observe the following precautions to prevent malfunction or adverse effects on the performance or functionality of the product. Not doing so may occasionally result in faulty operation.

1. This product is specifically designed for indoor use only.

Do not use this product in the following places:

- Places directly subject to heat radiated from heating equipment.
 - Places subject to splashing liquid or oil atmosphere.
 - Places subject to direct sunlight.
 - Places subject to dust or corrosive gas (in particular, sulfide gas and ammonia gas).
 - Places subject to intense temperature change.
 - Places subject to icing and condensation.
 - Places subject to vibration and large shocks.
2. Use and store the product within the rated ambient temperature and humidity.
Gang-mounting two or more Temperature Controllers, or mounting Temperature Controllers above each other may cause heat to build up inside the Temperature Controllers, which will shorten their service life. In such a case, use forced cooling by fans or other means of air ventilation to cool down the Temperature Controllers.
3. To allow heat to escape, do not block the area around the product. Do not block the ventilation holes on the product.
4. Be sure to wire properly with correct polarity of terminals.
5. Use the specified size of crimp terminals for wiring (M3.5, width of 7.2 mm or less). For open-wired connections use stranded or solid copper wires with a gauge of AWG24 to AWG14 (equal to a cross-sectional area of 0.205 to 2.081 mm²). (The stripping length is 5 to 6 mm.) Up to two wires of the same size and type or two crimp terminals can be connected to one terminal. Do not connect more than two wires or more than two crimp terminals to the same terminal.
6. Do not wire the terminals that are not used.
7. To avoid inductive noise, keep the wiring for the product's terminal block away from power cables carry high voltages or large currents. Also, do not wire power lines together with or parallel to product wiring. Using shielded cables and using separate conduits or ducts is recommended.
Attach a surge suppressor or noise filter to peripheral devices that generate noise (in particular, motors, transformers, solenoids, magnetic coils, or other equipment that have an inductance component).
When a noise filter is used at the power supply, first check the voltage or current, and attach the noise filter as close as possible to the product.
Allow as much space as possible between the product and devices that generate powerful high frequencies (high-frequency welders, high-frequency sewing machines, etc.) or surge.
8. Use this product within the rated load and power supply.
9. Make sure that the rated voltage is attained within two seconds of turning ON the power using a switch or relay contact. If the voltage is applied gradually, the power may not be reset or output malfunctions may occur.
10. Make sure that the Temperature Controller has 30 minutes or more to warm up after turning ON the power before starting actual control operations to ensure the correct temperature display.
11. A switch or circuit breaker must be provided close to the product. The switch or circuit breaker must be within easy reach of the operator, and must be marked as a disconnecting means for this unit.
12. Do not use paint thinner or similar chemical to clean with. Use standard grade alcohol.
13. Design the system (e.g., control panel) considering the 2 seconds of delay that the product's output to be set after power ON.
14. The output may turn OFF when shifting to certain levels. Take this into consideration when performing control.
15. The number of non-volatile memory write operations is limited. Therefore, use RAM write mode when frequently overwriting data during communications or other operations.
16. Always touch a grounded piece of metal before touching the Temperature Controller to discharge static electricity from your body.

17. Control outputs (for driving SSR) that are voltage outputs are not isolated from the internal circuits. When using a grounded thermocouple, do not connect any of the control output terminals to ground. (Doing so may result in an unwanted circuit path, causing error in the measured temperature.)
18. Use suitable tools when taking the Temperature Controller apart for disposal. Sharp parts inside the Temperature Controller may cause injury.
19. Do not use the Temperature Controller if the front sheet is peeling off or torn.
20. Check the orientation of the connectors on the USB-Serial Conversion Cable before connecting the Cable. Do not force a connector if it does not connect smoothly. Using excessive force may damage the connector.
21. Do not place heavy object on the USB-Serial Conversion Cable, bend the cable past its natural bending radius, or pull on the cable with undue force.
22. Do not connect or disconnect the USB-Serial Conversion Cable while communications are in progress. Product faults or malfunction may occur.
23. Make sure that the Conversion Cable's metal components are not touching the external power terminals.
24. Do not touch the connectors on the USB-Serial Conversion Cable with wet hands. Electrical shock may result.
25. The computer may operate incorrectly. Do not rapidly and repeatedly insert and disconnect the USB connector on the USB-Serial Conversion Cable.
26. The personal computer requires time to recognize the cable connection after the USB connector is connected to the personal computer. This delay does not indicate failure. Check the COM port number before starting communications.
27. The USB-Serial Conversion Cable may malfunction. Do not connect to a personal computer through a USB hub.
28. For the power supply voltage input, use a commercial power supply with an AC input. Do not use the output from an inverter as the power supply. Depending on the output characteristics of the inverter, temperature increases in the product may cause smoke or fire damage even if the product has a specified output frequency of 50/60 Hz.
29. Make sure that the indicators on the Temperature Controller are operating properly. Depending on the application conditions, deterioration in the connectors and cable may be accelerated, and normal communications may become impossible. Perform periodic inspection and replacement.
30. When extending or connecting the thermocouple lead wire, be sure to use compensating wires that match the thermocouple types.
31. When extending or connecting the lead wire of the platinum resistance thermometer, be sure to use wires that have low resistance and keep the resistance of the three lead wires the same.
32. The USB-Serial Conversion Cable may malfunction. Do not extend the USB cable with an extension cable to connect to the personal computer.
33. Noise may enter on the USB-Serial Conversion Cable, possibly causing equipment malfunctions. Do not leave the USB-Serial Conversion Cable connected constantly to the equipment.

Precautions for Correct Use

Service Life

1. Use the product within the following temperature and humidity ranges:
 Temperature: -10 to 55°C (with no icing or condensation)
 Humidity: 25% to 85%
 If the product is installed inside a control board, the ambient temperature must be kept to under 55°C , including the temperature around the product.
2. The service life of electronic devices like Temperature Controllers is determined not only by the number of times the relay is switched but also by the service life of internal electronic components. Component service life is affected by the ambient temperature: the higher the temperature, the shorter the service life and, the lower the temperature, the longer the service life. Therefore, the service life can be extended by lowering the temperature of the Temperature Controller.

3. When two or more Temperature Controllers are mounted horizontally close to each other or vertically next to one another, the internal temperature will increase due to heat radiated by the Temperature Controllers and the service life will decrease. In such a case, use forced cooling by fans or other means of air ventilation to cool down the Temperature Controllers. When providing forced cooling, however, be careful not to cool down the terminals sections alone to avoid measurement errors.

Measurement Accuracy

1. Mount the product so that it is horizontally level.
2. If the measurement accuracy is low, check to see if input shift has been set correctly.

Waterproofing

The degree of protection is as shown below. Sections without any specification on their degree of protection or those with IP□0 are not waterproof.

Front panel: IP66

Rear case: IP20, Terminal section: IP00

Operating Precautions

1. It takes approximately two seconds for the outputs to turn ON after the power supply is turned ON. Due consideration must be given to this time when incorporating Temperature Controllers in a sequence circuit.
2. When starting operation after the Temperature Controller has warmed up, turn OFF the power and then turn it ON again at the same time as turning ON power for the load. (Instead of turning the Temperature Controller OFF and ON again, switching from STOP mode to RUN mode can also be used.)
3. Avoid using the Controller in places near a radio, television set, or wireless installing. These devices can cause radio disturbances which adversely affect the performance of the Controller.
4. When complying with EMC standards, the cable connecting the sensor to the TC or Pt input must be 30 m or less. If the cable length exceeds 30 m, compliance with EMC standards will not be possible.

Mounting

Mounting to a Panel

For waterproof mounting, waterproof packing must be installed on the Controller. Waterproofing is not possible when group mounting several Controllers. Waterproof packing is not necessary when there is no need for the waterproofing function.

1. Insert the E5CB into the mounting hole in the panel.
2. Push the adapter from the terminals up to the panel, and temporarily fasten the E5CB.
3. Tighten the two fastening screws on the adapter. Alternately tighten the two screws little by little to maintain a balance. Tighten the screws to a torque of 0.29 to 0.39 N·m.

Precautions when Wiring

- Separate input leads and power lines in order to prevent external noise.
- Use AWG24 (cross-sectional area: 0.205 mm^2) to AWG14 (cross-sectional area: 2.081 mm^2) shielded twisted-pair cable.
- Use crimp terminals when wiring the terminals.
- Use the suitable wiring material and crimp tools for crimp terminals.
- Tighten the terminal screws to a torque of between 0.74 and 0.90 N·m.

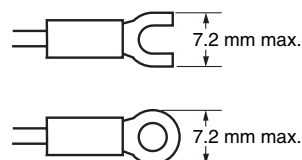

Warranty and Application Considerations

Read and Understand This Catalog

Please read and understand this catalog before purchasing the products. Please consult your OMRON representative if you have any questions or comments.

Warranty and Limitations of Liability

WARRANTY

OMRON's exclusive warranty is that the products are free from defects in materials and workmanship for a period of one year (or other period if specified) from date of sale by OMRON.

OMRON MAKES NO WARRANTY OR REPRESENTATION, EXPRESS OR IMPLIED, REGARDING NON-INFRINGEMENT, MERCHANTABILITY, OR FITNESS FOR PARTICULAR PURPOSE OF THE PRODUCTS. ANY BUYER OR USER ACKNOWLEDGES THAT THE BUYER OR USER ALONE HAS DETERMINED THAT THE PRODUCTS WILL SUITABLY MEET THE REQUIREMENTS OF THEIR INTENDED USE. OMRON DISCLAIMS ALL OTHER WARRANTIES, EXPRESS OR IMPLIED.

LIMITATIONS OF LIABILITY

OMRON SHALL NOT BE RESPONSIBLE FOR SPECIAL, INDIRECT, OR CONSEQUENTIAL DAMAGES, LOSS OF PROFITS, OR COMMERCIAL LOSS IN ANY WAY CONNECTED WITH THE PRODUCTS, WHETHER SUCH CLAIM IS BASED ON CONTRACT, WARRANTY, NEGLIGENCE, OR STRICT LIABILITY.

In no event shall the responsibility of OMRON for any act exceed the individual price of the product on which liability is asserted.

IN NO EVENT SHALL OMRON BE RESPONSIBLE FOR WARRANTY, REPAIR, OR OTHER CLAIMS REGARDING THE PRODUCTS UNLESS OMRON'S ANALYSIS CONFIRMS THAT THE PRODUCTS WERE PROPERLY HANDLED, STORED, INSTALLED, AND MAINTAINED AND NOT SUBJECT TO CONTAMINATION, ABUSE, MISUSE, OR INAPPROPRIATE MODIFICATION OR REPAIR.

Application Considerations

SUITABILITY FOR USE

OMRON shall not be responsible for conformity with any standards, codes, or regulations that apply to the combination of products in the customer's application or use of the products.

Take all necessary steps to determine the suitability of the product for the systems, machines, and equipment with which it will be used.

Know and observe all prohibitions of use applicable to this product.

NEVER USE THE PRODUCTS FOR AN APPLICATION INVOLVING SERIOUS RISK TO LIFE OR PROPERTY WITHOUT ENSURING THAT THE SYSTEM AS A WHOLE HAS BEEN DESIGNED TO ADDRESS THE RISKS, AND THAT THE OMRON PRODUCTS ARE PROPERLY RATED AND INSTALLED FOR THE INTENDED USE WITHIN THE OVERALL EQUIPMENT OR SYSTEM.

Disclaimers

PERFORMANCE DATA

Performance data given in this catalog is provided as a guide for the user in determining suitability and does not constitute a warranty. It may represent the result of OMRON's test conditions, and the users must correlate it to actual application requirements. Actual performance is subject to the OMRON *Warranty and Limitations of Liability*.

CHANGE IN SPECIFICATIONS

Product specifications and accessories may be changed at any time based on improvements and other reasons. Consult with your OMRON representative at any time to confirm actual specifications of purchased product.

DIMENSIONS AND WEIGHTS

Dimensions and weights are nominal and are not to be used for manufacturing purposes, even when tolerances are shown.

OMRON Corporation Industrial Automation Company

Tokyo, JAPAN

Contact: www.ia.omron.com

Regional Headquarters

OMRON EUROPE B.V.

Wegalaan 67-69-2132 JD Hoofddorp
The Netherlands

Tel: (31)2356-81-300/Fax: (31)2356-81-388

OMRON ELECTRONICS LLC

One Commerce Drive Schaumburg,
IL 60173-5302 U.S.A.

Tel: (1) 847-843-7900/Fax: (1) 847-843-7787

OMRON ASIA PACIFIC PTE. LTD.

No. 438A Alexandra Road # 05-05/08 (Lobby 2),
Alexandra Technopark,
Singapore 119967

Tel: (65) 6835-3011/Fax: (65) 6835-2711

OMRON (CHINA) CO., LTD.

Room 2211, Bank of China Tower,
200 Yin Cheng Zhong Road,
PuDong New Area, Shanghai, 200120, China

Tel: (86) 21-5037-2222/Fax: (86) 21-5037-2200

Authorized Distributor:

© OMRON Corporation 2010 All Rights Reserved.
In the interest of product improvement,
specifications are subject to change without notice.

Cat. No. H172-E1-01

Printed in Japan
1110